

Eckart Modrow

Computer Science

with  Snap!

– Snap! by Examples –

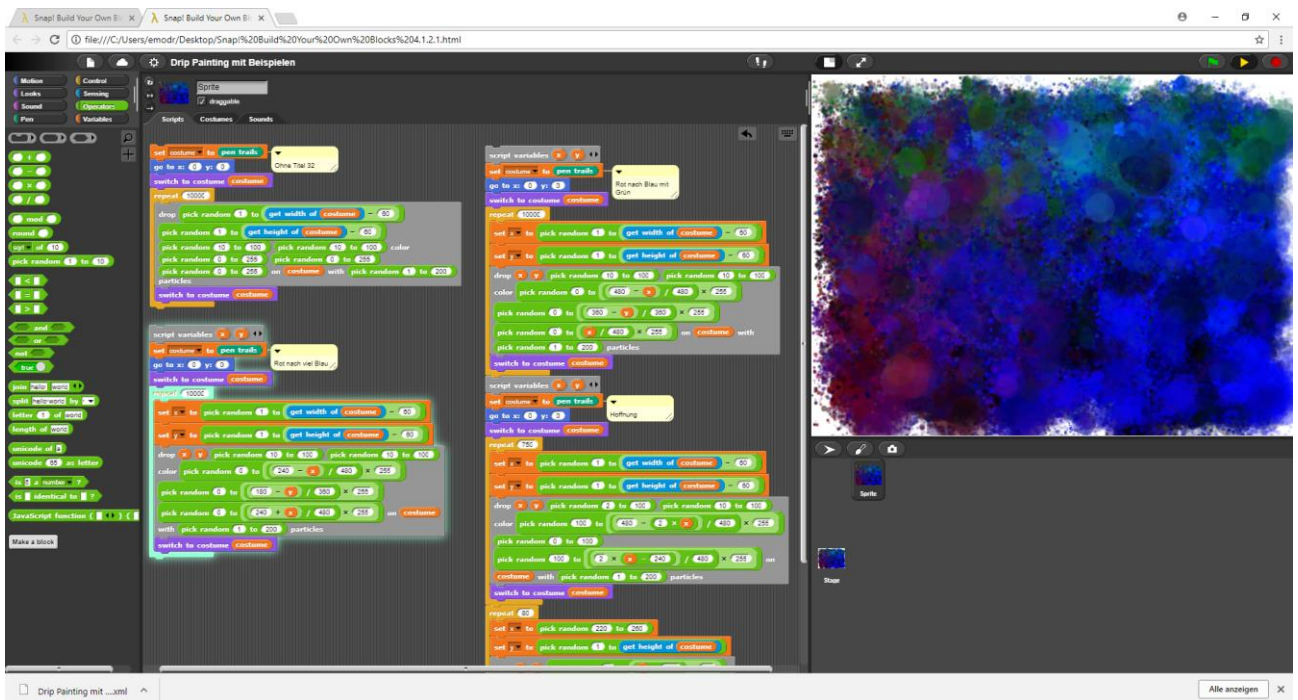

© Eckart Modrow 2018

emodrow@informatik.uni-goettingen.de



This work is licensed under a Creative Commons Attribution-NonCommercial-Share Alike 4.0 International License. It allows download and redistribution of the complete work with mention of my name, but no editing or commercial use. In addition to the book, the complete listings of the described programs are loadable from the following address:

<http://emu-online.de/projectsOfCSwithSnap.zip>

The scripts are developed with Snap! 4.1.2.1 Build Your Own Blocks.

Prof. Dr. Modrow, Eckart:
Computer Science with *Snap!*
- *Snap!* by Examples -
© emu-online Scheden 2018
All rights reserved

If this book is helpful for you and you would like to express your appreciation in form of a donation, you can do so at the following PayPal account:

emodrow@emu-online.de
Intended use: Snap! book



This publication and its parts are protected by copyright. Any use in others than legally permitted cases requires the prior written consent of the author.

The software and hardware names used in this book as well as the brand names of the respective companies are generally subject to the protection of goods, trademarks and patents. The product names used are protected by trademark law for the respective copyright holders and cannot be freely used.

This book expresses views and opinions of the author. No guarantee is given for the correct executability of the given sample source texts in this book. I assume no liability or legal responsibility for any damages resulting from the use of the source texts of this book or other incorrect information.

Preface

This book, similar to its predecessor "*Informatik mit BYOB*"¹, uses a collection of programming examples to explore the scope of the graphical language *Snap!*. It does not replace a textbook that conveys CS content but shows how to use *Snap!* to apply CS methods.

After *Scratch* and *BYOB*, *Snap!* in the current version 4.1.2 is the next step in the development of graphical tools. The system overcomes several limitations that existed with its predecessors, so it overcomes many arguments against graphical languages. The current version has been expanded by numerous extensions in the field of object-oriented programming (OOP). It can meet and exceed all requirements up to high school and beyond. Since drastic improvements have been achieved at the execution speed and availability of libraries in different fields like pixel access, audio or use of external resources, there are hardly any restrictions in applications. Particularly noteworthy in this area is the possibility to use Java-Script functions, e.g. for time-critical operations or extensions within *Snap!*. The libraries contain numerous JavaScript-examples.

The selection of problems in the following chapters is relatively conservative, partly based on existing computer science lessons, but it goes beyond that. That's intended. I hope, on the one hand, to convert teachers using traditional lessons, and on the other hand, to provide contexts that brings sense from the perspective of a learner to the information to be acquired. In this way, teaching should be very much based on CS concepts AND creativity. The examples describe in detail the handling of *Snap!* in different aspects. After an introductory chapter that gives a fast overview about *Snap!*, the first few chapters explain the features of the language, followed by sections without any obvious application. This compromise is due to space requirements, because advanced concepts require extended problems. The examples are not hierarchically ordered, so in the second part are also rather simple ones. At the end of the book there are summaries of the methods used in the examples and an index.

This book is a translation from German. Unfortunately, I do not speak English well, so it will be bumpy. I apologize for that. But all of the programs had to be changed – a task that I really had to do. Be strong and hold it! Many thanks for the wonderful help of the *DeepL*² translation program. I would probably never have finished without these.

I would like to thank Jens Mönig for his support - and for the results of his work. The learners will be thankful!

I wish you a lot of fun working with *Snap!*.

Göttingen, am 1.4.2018

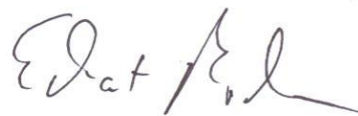

¹ E. Modrow, *Informatik mit BYOB*, <http://ddi-mod.uni-goettingen.de/Informatik%20mit%20BYOB.pdf>

² <https://www.deepl.com/translator>

Content

Preface	3
Content	4
1 CS and Media Studies	7
2 About Snap!	9
2.1 Block Oriented Languages	9
2.2 Object Oriented Languages	9
2.3 Inheritance by Delegation	10
2.4 What is Snap!?	11
2.5 What is Snap! not?	12
2.6 The Snap!-Screen	13
2.7 An Example for Experienced Users: Flu	14
2.7.1 Writing Your Own Methods	15
2.7.2 Elementary Algorithmic and Variables	16
2.7.3 Creating Objects	17
2.7.4 Communicating with Objects	18
2.7.5 Drawing a Diagram	21
3 Simple Examples	23
3.1 Swimming	23
2.2 Solar System	25
2.3 Caesar Encryption	27
2.4 Tasks	29
4 Simulation of a Spring Pendulum	30
4.1 Organization of Cooperation	30
4.2 The Clock	32
4.3 The Exciter	32
4.4 The Thread	33
4.5 The Ball	33
4.6 The Pen	34
4.7 Why is it a simulation?	34
5 Troubleshooting with Snap!	35
6 Lists and Related Structures	37
6.1 Selection Sort	37
6.2 Quicksort	39
6.3 Routing with Dijkstra Method	40
6.4 Matrices and FOR-Loops	44
6.5 Tasks	46
7 Object-Oriented Programming	47
7.1 Anne and the Filing Cabinets	48
7.2 Magnets	52
7.3 A Learning Robot	53

7.4	A Digital Simulator	57
7.4.1	Sockets and Connections	58
7.4.2	Switches	59
7.4.3	Gates	60
7.4.4	The Pen	60
7.4.5	LEDs	61
7.4.6	The Interaction of the Components	61
7.4.7	Tasks	62
8	Graphics	63
8.1	Line Graphics	63
8.2	Pixel Graphics and RGB Model	66
8.2.1	Pixel Graphics with the Pixels Library	66
8.2.2	Pixel Graphics with an own Library	68
8.3	The Light of the old Stars	70
8.4	A simple RGB Color Mixer	71
8.5	Drip Painting	72
8.6	Edge Detection	74
8.7	Tasks	76
9	Image Recognition	77
9.1	A Barcode Scanner	77
9.2	Project: Transit Prohibited!	82
9.3	Project: Face Recognition	88
9.4	Tasks	94
10	Sounds	95
10.1	Find Sounds	95
10.2	Processing Sounds.....	96
10.3	Making Music	97
10.4	Project: Hearing check	99
10.5	Tasks	100
11	Project: Electrons in Fields	101
11.1	Electron Source and Set-Up	101
11.2	Capacitor and Electric Field	102
11.3	Helmholtz Coils and Magnetic Field	103
11.4	The Electrons	104
12	Texts and Related Topics	106
12.1	Operations on Strings	106
12.2	Vigenère Encryption	109
12.3	DNA-Sequencing	111
12.4	Text Files and Frequency Analysis	113
12.5	SQL-Databases	117
12.6	Tasks	123

13	Computer Algebra: Functional Programming	124
13.1	Function Terms	124
13.2	Parsing of Function Terms	125
13.3	Derivation of Function Terms	129
13.4	Calculation of Function Results and Graphs	131
13.5	Tasks	134
14	Artificial Plants: L-Systems	135
14.1	L-Systems	135
14.2	Create the Drawing Instruction	136
14.3	The Stack Operations	136
14.4	Drawing the Plants	137
14.5	Tasks	138
15	Automata	139
15.1	Correct Mail Addresses	139
15.2	Hyphenation: Kevin Speaks	141
15.3	Coupled Turing Machines	145
15.4	Cellular Automata: Iterated prisoner's dilemma	149
15.5	Tasks	155
16	Projects	156
16.1	LOGO for the Poor	156
16.2	SnapMinder by Jens Mönig	163
16.2.1	Importing Table Data	164
16.2.2	The SnapMinder Data	165
16.2.3	The SnapMinder Countries	167
16.2.4	Use SnapMinder	168
16.3	Connectivity: The World is Small	169
16.3.1	Random Networks	170
16.3.2	Scalefree Networks	171
16.3.3	The Implementation	172
16.4	Evolution	176
16.5	Using the Sensorboard Calliope	180
16.6	Rate Websites: PageRank	182
17	At the Supermarket	188
17.1	Warehouse Management with SQLite	189
17.2	The Scanning Cash Register	192
17.3	The Smart Scale	194
17.4	License Plate Recognition	200
17.5	The Advertising Department	206
	About the Notation of <i>Snap!</i> -Programs	208
	How to ... ?	210
	Index	212

1 CS and Media Studies

In schools and universities, there is a lot of discussion about media literacy as part of the "digitization offensive". Since the term "digitization" obviously concerns computer science, CS should participate in the discussion. Educational institutions need to think carefully about their contribution to a comprehensive education. On the one hand, children and adolescents also gain knowledge and experience - and in many areas predominantly - outside of these institutions; on the other hand, the objectives of "education" and "vocational training" should be sharply differentiated. Adolescents do not necessarily have to master the handling of current tools, they can confidently leave that to the adults. But they must be prepared to take on the appropriate role with future tools.

It is often argued that learners must learn to use modern media to lose the "fear of them". I think that is wrong. First, children and adolescents are usually simply curious and not afraid of media. Second, they learn to handle media quickly and easily by others and by use. The fear is more on the side of the elderly, who did not grow up with this technique and therefore feel insecure with it. Older people should remember that in their youth, they had a hard time showing their elders how to use a computer mouse. We can learn from this situation that the handling of current technology - such as smartphones - can be acquired by the way, but obviously this does not lead automatically to an uncomplicated use of future technology.

Goal 1: Learners need to be empowered to understand the basics of future technologies and to acquire their use.

Media usage is not the same as media consumption. The passive use of media of whatever kind, e.g. simple "gawking", cannot be the goal of the educational system. When we engage with media, they must be in a context that activates learners.

Goal 2: Learners need to be empowered to select and deploy tools to create media based on their problem. So, they first must learn how to solve problems independently.

Independent problem solving usually is not seen as a central task, at least in schools. Creative subjects such as art, music and (most) languages (hopefully) at least sometimes strive for this. All too often, "well-behaved" learning is the primary goal. CS can provide tools to realize and test one's own ideas even in relatively rudimentary form. Not to realize creative lessons would be a missed chance. However, this will only work if the teachers themselves have experiences in independent, creative problem-solving, and if they trust in the learners accordingly. If teachers only have learned CS content in a "well-behaved" way, then creativity in the classroom is hard to achieve. If the second goal is to be realized in schools, this should and must also have consequences for teacher training at universities.

Goal 3: Teachers need to be empowered to plan and realize creative lessons. There should be opportunity and time in their own studies.

Modern media such as social networks have profoundly changed social life, communication, etc. The consequences are hard to predict while this process continues and couldn't be imagined before it started. It would overtax any teacher if it was demanded that they address the actual social consequences of computer science systems in the classroom, which include the impact of digital media. That would not be expedient, because the view

on “what has happened” necessarily is turned backwards. But what you can ask for is to show that the use of computer systems has social consequences and that these depend very much on how the systems are designed. Different problem solutions have different consequences - and vice versa: If certain consequences are undesirable, then it will usually be possible to find another technical problem solution.

Goal 4: Learners need to know that there are almost always different solutions to problems. You should think about their effects, which of course are not conclusive. They learn that these effects are not given but can be shaped.

Why does this affect *Snap!*?

Graphical programming tools like *Snap!* do not only contain the algorithmic components of any programming language, they are also embedded in a media environment that not only allows the use of graphics, sound, ... but requires it. When a problem is handled, cameras and graphics programs can and should be used to create the appropriate costumes and costume changes that visualize the current state of the system. Sound programs make it possible to comment on the course itself, to edit and insert music or to design it yourself. And, of course, the results must be presented because product pride is an important motive for the dedicated work. And there is much interest in the results of others. *Snap!* allows algorithmic problem solving at a very high level, but it not only allows the analytical approach, but also the playful, the experimental, the creative, ... Not allowed is passivity, because nothing happens by itself. Media are essential system components, e. g. to visualize the results - and they can also be the result itself. *Snap!* therefore offers the opportunity to model problem solutions for current problems, also and especially in the field of media. The self-created algorithmic framework of the model creates understanding of the observed processes in real life. The experience of being able to gain this insight enables active, critical analysis of future technology. The examples in this book are intended to show that this is possible in many areas using elementary methods. They should encourage you to get started yourself. 😊

2 About Snap!

2.1 Block Oriented Languages

*Snap!*³ is a successor of *BYOB* (*Build Your Own Blocks*), whose name already describes part of the program: the users at schools and universities use existing commands in the form of blocks and are enabled to develop own new blocks. Their programs (*scripts*) are combinations of both. You must know that almost all programming languages are block-oriented: command sequences can be grouped with a new name. The resulting new commands can use values (*parameters*) to work with, if needed, and they can return results. This gives us several advantages:

- **Programs become shorter** because program parts are swapped out into the blocks. Multiply used command sequences are written only once and then reused under the new name.
- **Programs contain fewer errors** because blocks are developed and tested largely independent. The developed command sequence thus remains short and clear. "Long" program parts are rarely necessary and usually a sign of poor programming style.
- **Programs get their own style** because the new commands reflect the way a programmer solves problems.
- **The programming language is extended** because the created blocks represent new commands and thus new possibilities.

Advantages of
block-oriented
languages

2.2 Object Oriented Languages

When dealing with more extensive problems, the number of subproblems to be solved increases. Often these can be combined to groups which can be assigned to concrete objects. Often, these sub-problems appear time and again, so they can be solved when appropriate objects are provided, e. g. in libraries. An important aspect of this way of working is that it allows teamwork to be carried out well, with the different teams creating objects that solve part tasks. Of course, the results must be put together. The object-oriented approach is often realized by creating classes that describe the behavior of a group of similar objects. From these classes instances are created that are supposed to solve the problems. In contrast *Snap!* realizes a prototype-based approach. For each object an example, the *prototype*, is generated and tested step by step. If one is satisfied with the result, further objects of this kind are derived by duplication (*cloning*) of the prototype. This way is better for beginners.

The object-oriented approach has following advantages:

Problems become understandable because sub-problems can be assigned to objects and (largely) solved independently.

Problems become clearer because the division into objects often corresponds to the intuitive view, so that "everyday knowledge" can be incorporated into the solutions.

Advantages of
object-oriented
languages

³ <http://snap.berkeley.edu/snapsource/snap.html>

Problem-adapted tools can be provided because corresponding libraries exist or are created.

Collaboration is facilitated because object-oriented work suggests the broader isolation of problem solving so that the different groups are less disturbed.

2.3 Inheritance by Delegation

The concept of inheritance is central to object-oriented programming. It can be realized by classes or by delegation. In the original article by Lieberman⁴, who describes the prototype-oriented approach to delegation very early, objects are understood as the embodiment of the concepts of their class. For example, the elephant *Clyde* stands for everything the observer knows about an elephant. If one imagines an elephant, there appears no abstract class of elephants, but just *Clyde*. When one talks about another elephant, here: *Fred*, he describes it like this: "*Fred is like Clyde, just white.*"



What does this approach mean for the learning process? If the learner only knows one copy of a class (here: Clyde), the prototype completely describes his knowledge, an abstraction is pointless for him. If he later learns about other specimens and describes them through modifications to the original, thus replacing some methods with others, changing attributes and adding new ones, then slowly the image of the class itself emerges as an intersection of the common properties. Now the process of abstraction is comprehensible for him and after a few attempts also feasible. Delegation thus is a process that maps the learning process itself by creating prototypes instead of classes.

In *Snap!* we mainly work according to this principle, which is presented below in detail. If you really want, a class system also can be implemented.

In *Snap!* sprites are created as prototypes and equipped with the desired attributes and methods. If their behavior has been sufficiently tested, clones can be generated dynamically using the *clone* block. Each sprite has a *parent* (may be *null*) and *children* (also may be *null*). The *parent* property can be set and / or modified later, so the system of dependencies is dynamic. If the program stops, all dynamically generated clones are deleted, which is beneficial.

cloning sprites

At first, a clone inherits (almost) all the attributes and methods of the mother object. This is indicated by a "paler" representation in the palettes. If a sprite overrides inherited attributes or methods, they replace those of the prototype, as usual. If you delete the overrides again, then the inherited appear.

⁴ Lieberman, Henry: Using Prototypical Objects to Implement Shared Behavior in Object Oriented Systems, 1986, <http://web.media.mit.edu/~lieber/Lieberary/OOP/Delegation/Delegation.html>

2.4 What is Snap!?

Snap! was (and is) developed by *Brian Harvey* and *Jens Mönig* for the project *Beauty and Joy of Computing*⁵ and is made freely available on the internet. Since the system runs in the browser, it does not require any installation and works on almost all devices⁶. It is similar in surface and behavior to *Scratch*⁷, a free programming environment for children developed at *MIT*⁸. However, the concepts implemented in *Snap!* go far beyond *Scratch* and have their roots in decades of teaching CS at MIT with *Scheme*, a *LISP* language. They are introduced e. g. in a famous textbook by *Harold Abelson* and *Gerald and Julie Sussman*⁹. *Snap!* is thus a fully developed programming language that can be used for (almost) all problems. For most, it is sufficiently fast now. That is not self-evident and was a shortcoming of their predecessors. Graphical languages are largely concerned with controlling the state of the system. For example, to allow you to interrupt endless loops or to "tolerate" access errors to data structures. There remains little time for program execution.

the developers

origins at Lisp

Snap! is a graphical programming language: programs (scripts) are not entered as text but composed of tiles. Since these tiles can only be joined together if this makes sense, "misspelled" programs are largely prevented. *Snap!* therefore is largely syntax-free. Nevertheless, it is not entirely free of syntax, because some blocks can handle different combinations of inputs: if you combine them incorrectly, errors can occur. However, this mostly happens when using very advanced *Snap!* concepts. If you apply these, you should know what you are doing.

barely
syntax errors

Snap! is extremely "peaceful": mistakes do not lead to program crashes but are indicated by the appearance of a red marker around the tiles that caused the error - without dramatic consequences. The used tiles, which include the newly developed blocks, always "live". They can be executed by mouse clicks so that their effect is directly observable. This makes it easy to experiment with the scripts. They can be tested, changed, broken down into parts and put together the same or different. This gives us a second access to programming: in addition to problem analysis and the associated *top-down* approach, the experimental *bottom-up* construction of subprograms, which can be put together to form a complete solution.

two styles of
programming

Snap! is clear: both program sequences and assignments of the variables can be displayed and tracked on demand on the screen.

vivid and expandable

Snap! is extensible: with the implemented LISP concepts, new control structures can be created, e. g. to work with special data structures.

Snap! is object-oriented, even in different ways: Objects can be generated by creating prototypes with subsequent delegation, as well as in different ways by classes.

object-oriented

⁵ <https://bjc.berkeley.edu/>

⁶ These are, of course, computers, tablets, smartphones, ...

⁷ <http://scratch.mit.edu/>

⁸ Massachusetts Institute of Technology, Boston

⁹ Abelson, Sussman: Struktur und Interpretation von Computerprogrammen, Springer 2001

Snap! is first-class: all structures used are first-class, so they can be assigned to variables or used as parameters in blocks, can be the result of a function block or content of a data structure. Furthermore, they may be untitled (anonymous), which is important for the implemented aspects of the lambda calculus, the basis of LISP. Consequently, the logo of *Snap!* contains the same proud Lambda, which builds the hair of *Alonzo*, the mascot of *BYOB*.



Alonzo

2.5 What *Snap!* is not!

Snap! is not a tool for professional software production. It started as a technology study commissioned by the American Ministry of Education under CE21 (*Computing Education for the 21st Century*), which is also designed to reduce the drop-out rate in technical subjects. It is a tool to implement and test CS concepts by way of example.

Snap! primarily is used for work in the field of algorithms and data structures. Due to the browser environment, essential areas of computer science such as access to files or hardware can be embedded via extensions but are not (yet) part of the core language. However, the built-in *url*-block allows in the meantime quite easy access to the Internet and thus using intermediary servers to databases or external hardware. Both are included in the book.

Since the code of *Snap!* is freely available, there are different versions, sometimes with substantial modifications. Whether this is a curse or a blessing, is a question of perspective, as we shall see.

the limits

2.6 The Snap!-Screen

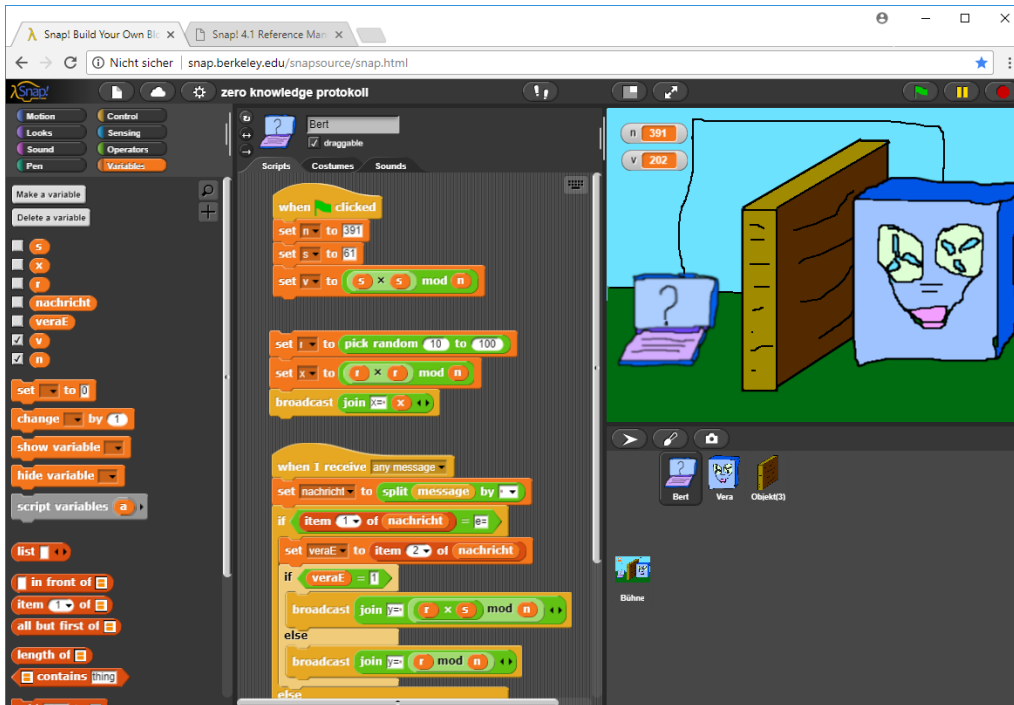

The *Snap!*-Screen consists of six sections below the menu bar ¹⁰.

- On the far left are the command tabs, divided into the categories *Motion*, *Looks*, *Sound* and so on. If you click on the corresponding button, the tiles of this category are displayed below. If they don't fit all on the screen, you can scroll the screen area in the usual way.
- To the right, in the middle of the screen, the *name* of the object currently being edited as well as some of its properties are displayed. The default name of the sprite can - and should - be changed here.
- Underneath is an area in which, depending on the tab, the *scripts*, *costumes* and *sounds* of the sprite can be edited or created.
- At the top right is the *output window* where the sprites move. This can be resized using the buttons above or via the entry in the tool menu (*Stage size ...*).
- At the bottom right, the sprite corral displays the sprites. If you click on one, the middle section changes to its scripts, costumes or sounds - depending on the selection.
- The menu bar on the left offers the usual menus for loading and saving the project as well as individual sprites. Furthermore, many settings can be made. One possibility is to set the language. Nevertheless, I recommend that you stay with the English version, as it is possible to differentiate your own blocks, titled e. g. in German, from the native ones at first glance.
- On the far right we find the green flag known from Scratch, with which several scripts can be started at the same time when using the corresponding block. The pause button next to it pauses everything accordingly and the red button stops all running scripts. Individual scripts or tiles can be started simply by clicking on them.

Sprite-bezogene
Einstellungen



the tool menu

the menu bar



¹⁰ The division of the areas can be changed with .

2.7 An Example for Experienced Users: Flu

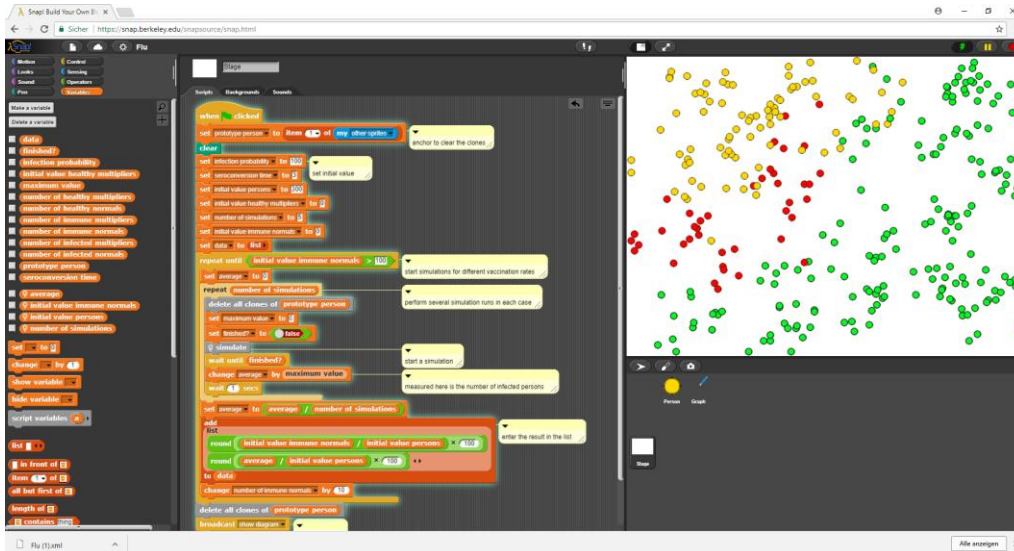

The example simulates the spread of a flu epidemic under different conditions. It provides a quick overview of the essential features of *Snap!* and is intended especially for experienced programmers. Beginners should read the next chapters first.

The question is which proportion and which special groups of people in a population should be vaccinated if the spread of a flu epidemic is to be stopped. The question is not so easy to answer, because the outcome depends on several parameters: the *likelihood of infection* indicates how probable the infection of a healthy person in contact with a sick person is, the *seroconversion time* is the time between infection and immunization, the *numbers of healthy and diseased persons* at the beginning of the simulation determines the number of contacts between them, and the number of *multipliers* indicates how many people in the population have particularly large numbers of contacts or contacts to particularly distant groups. If one of them becomes infected, e. g. the disease will be worn in distant areas. Since contacts, infections, ... are randomized, we will only achieve sustainable results if we perform the simulation multiple times with the same parameter values - and after that we still must discuss which values represent "results" in the sense mentioned. That's why the topic is perfect for a small classroom project. A "control group" develops the higher-level scripts, in this case assigned to the *stage*. It designs the task distribution with the other two groups. The other groups develop the prototypes *person* and *graph*, which are largely independent of each other.

three prototypes
for three groups

2.7.1 Writing Your Own Methods

At various points it is necessary to get rid of the clones of a prototype without exiting the program. We achieve that by a new method *delete all clones of <prototype>*. It is a *Command* block, which is a command with (in this case) one parameter. (Function blocks are called *Reporter* in *Snap!*.) New blocks are written in the block editor. It can be started with the buttons *Make a block* we find in the palettes or – the fastest way – by right-clicking on the script layer and calling it from the context menu. First, we specify the method name, if desired with blanks and special characters, select the type (*Command*, *Reporter*, or *Predicate*) and indicate whether it's a global ("for all sprites") or local ("for this sprite only") method. We can also choose the palette to which the block is to be included. I do not recommend this: The best place to find the gray self-written blocks is the bottom of the Variables palette. For example, if you evaluate student programs, it is often a problem to find the newly created blocks at all.

After pressing the return key, the Block editor opens, and the block name appears – with + characters in the spaces and margins. There, we can open another menu by mouse clicks, which allows to insert parameters in these places and to assign types to them if necessary. In our case, we click on the far right, enter the parameter identifier *prototype* and click the small right arrow to specify the typing. After that a selection box opens¹¹. We choose as type *Object* (the arrow), come back into the Block editor, and drag the required commands into its script area.

Our method uses two script variables (*clones* and *thisClone*) known only in this block. It asks the parameter *prototype*, which later is passed with a reference to the prototype of all persons, for its descendants – these are all occurring dynamically generated "persons"¹². As long as these are still available, it will store the first in one of the script variables, delete them from the list, and then ask that person to delete themselves, with *tell <thisClone> to <delete this clone>*¹³.

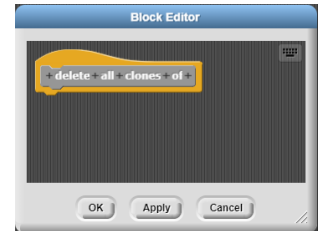
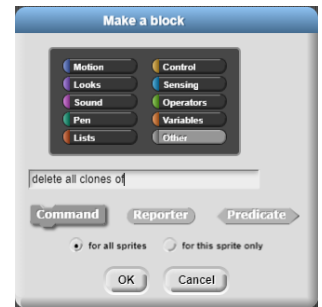

¹¹ This box is described in detail in the snap-reference manual that you get when you click the Snap! icon on the top-left of the window.

¹² The clones created statically through the context menu in the sprite area are not found there.

¹³ The delete block can only be found in the palettes of the sprites. You can reach it in the stage via the search function at the top of the palette area.

2.7.2 Elementary Algorithmic and Variables

To define the parameters and other control values, we use the *stage*, which we click in the sprite corral. This responds to the message "go" by setting the initial parameters and determining which quantities are to be measured in the simulations. Thereafter, corresponding simulation runs are started.

In detail: Since initially only the prototype *person* is available, we "fish" for him using the block *my <other sprites>* from the *Sensing* palette. The prototype is the first element of the received list. We store it in the global ("for all Sprites") variable *prototype person* that we created previously in the *Variables* palette. We also created all the other required variables via the *Make a variable* button, with the ones needed only within the stage being marked as local ("for this sprite only"). You can recognize them at the "marker" before the name. The others are global. Global variables are displayed at the top of the *Variables* palette, then follow the local ones. The output area is cleared (there might be an old graphic), some variables get appropriate initial values and a list called *data* to record the simulation results will be deleted (*set <data> to <list>*). This part could have been well outsourced to a separate block, but since we want to experiment with the variable values, it is better if they are "on the table".

In the following, the number of initially vaccinated (the *immune normal*) is increased from zero to 100 in steps. We find the control structures for this in the *Control palette*. For each value, a series of simulation runs is performed, and the mean value is determined from the results (here: the maximum number of infected). The variable *number of simulations* determines how often this happens. After each run, the results are entered as a percentage in the *data* list. Finally, the *Graph* sprite will be asked to create a graphic.

The screenshot shows a Scratch script for a simulation. The script starts with a 'when clicked' event block. It then sets 'prototype person' to the first item of 'my other sprites'. A 'clear' block is used to reset variables. Several 'set' blocks initialize variables: 'infection probability' to 100, 'seroconversion time' to 3, 'initial value persons' to 300, 'initial value healthy multipliers' to 0, 'number of simulations' to 1, and 'initial value immune normals' to 0. A 'set data to list' block is also present. A 'repeat until' loop runs while 'initial value immune normals' is less than 100. Inside this loop, 'average' is set to 0. A 'repeat number of simulations' loop follows. Inside this loop, 'delete all clones of prototype person' is called, 'maximum value' is set to 0, 'finished?' is set to false, 'simulate' is called, 'wait until finished?' is used, 'change average by maximum value' is called, and 'wait 1 secs' is used. After the inner loop, 'set average to average / number of simulations' is called. A large 'add list' block contains two 'round' blocks: 'round (initial value immune normals / initial value persons * 100)' and 'round (average / initial value persons * 100)'. The result is added to 'data'. 'change initial value immune normals by 10' is called. 'delete all clones of prototype person' is called, and 'broadcast show diagram' is called. Annotations explain: 'anchor to clear the clones', 'set initial value', 'start simulations for different vaccination rates', 'perform several simulation runs in each case', 'start a simulation', 'measured here is the number of infected persons', and 'enter the result in the list'.

Variable name: prototype person
 for all sprites for this sprite only
 OK Cancel

Make a variable
 Delete a variable

- data
- finished?
- infection probability
- initial value healthy multipliers
- maximum value
- number of healthy multipliers
- number of healthy normals
- number of immune multipliers
- number of immune normals
- number of infected multipliers
- number of infected normals
- prototype person
- seroconversion time
- average
- initial value immune normals
- initial value persons
- number of simulations

set to 0
 change by 1

when clicked

set prototype person to item 1 of my other sprites

clear

set infection probability to 100

set seroconversion time to 3

set initial value persons to 300

set initial value healthy multipliers to 0

set number of simulations to 1

set initial value immune normals to 0

set data to list

repeat until initial value immune normals > 100

set average to 0

repeat number of simulations

delete all clones of prototype person

set maximum value to 0

set finished? to false

simulate

wait until finished?

change average by maximum value

wait 1 secs

set average to average / number of simulations

add list

round initial value immune normals / initial value persons * 100

round average / initial value persons * 100

to data

change initial value immune normals by 10

delete all clones of prototype person

broadcast show diagram

anchor to clear the clones

set initial value

start simulations for different vaccination rates

perform several simulation runs in each case

start a simulation

measured here is the number of infected persons

enter the result in the list

draw diagram

2.7.3 Creating Objects

In addition to the script already described, the control program uses another one: *simulate*. In it, some initial values are reset, and the corresponding number of persons are generated, which differ in type (*normal*, *multiplier*) and status (*healthy*, *infected*, *immune*). After that the simulation run is started by sending the message "come on!" which is heard by all objects in the system.

How to create objects?

In the method we *create a person type: <type> and status: <status>*. A local script variable *p* references a newly created clone of the specified prototype. After that, the clone is present, visible and accessible under the name *p* – quite simple.

However, the clones should differ in type and status. For this, they contain (here) a local method inherited from the prototype *setup <status> <typ>*. We have to call these with the given parameter values. We therefore "tell" the object *p* that it should execute this method. As this is local to persons, we take the *<attribute> of <object>* Block from the *Sensing* palette, select the prototype in the right-hand box (here: *Person*) and after that in the left box the desired method (here: *setup*). Because two parameters are to be specified, we expand the block with the small arrow keys and enter status and type behind *with inputs*. The block is to be understood as "*p*, please execute in your context of methods and variables the method passed with the specified parameters". The block is equivalent to the well-known dot notation of the OOP languages: *p.setup(status, type)* ;

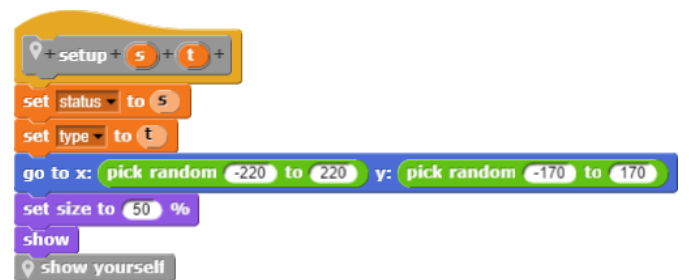
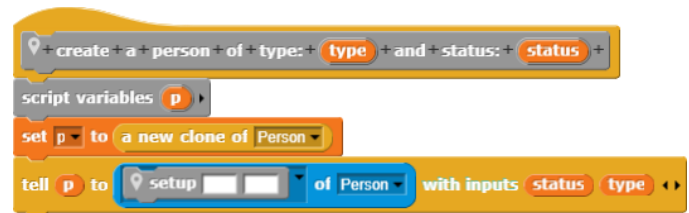
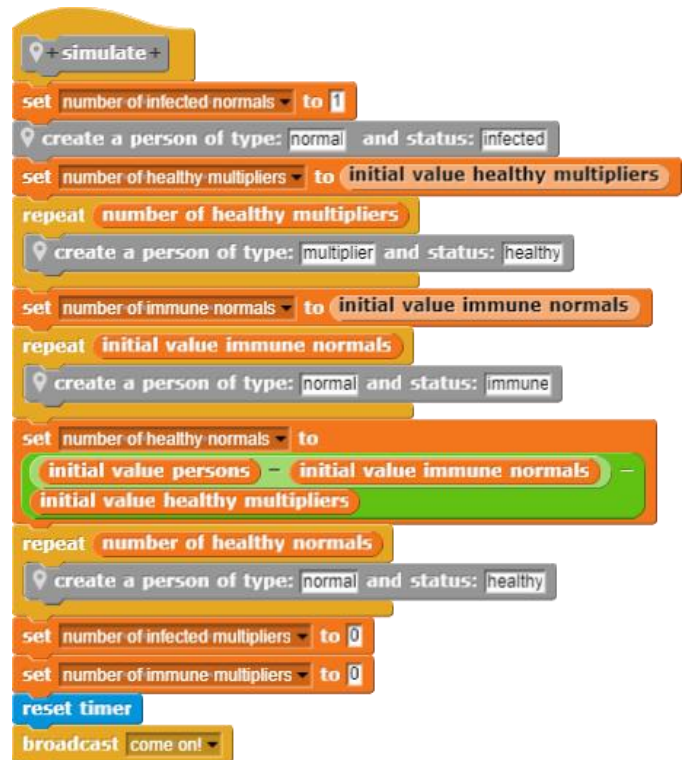

invoked methods in *Person*

2.7.4 Communicating with Objects

We are now coming to the actual players in our flu project: the persons. These are symbolized by small circles whose color expresses their status. "Normal" persons scurry around relatively small-step in their environment and meet the neighbors, where they can be infected or can infect. After a certain period, the seroconversion time, they become immune and do no longer infect, are no longer infected. Vaccinated persons are immune from the beginning. Some of the people are "multipliers", i.e. they jump quite wildly around the area and can spread the infection quickly. They are color coded like the normal, but slightly different. We produce appropriate costumes in the graphic editor or a drawing program and import them into the *Costumes* section.

Once the persons are created, they all receive all the message "come on! ". They respond to this message because they have a *hat-block* from the *control* palette that responds to "come on! ". After that, they get into an infinite loop that only breaks when the global variable *finished?* gets the value *true*. This is the case when there are no more infected.

In this loop, the following actions are performed repeatedly:

1. Objects are searched near the person and stored in the list *neighbors*. Too far objects are deleted in this list.
2. Any remaining neighbors may become infected or infect the person if they are ill.
3. It is checked whether the person has to be immune, if the Seroconversion time has expired. The corresponding variables are changed.
4. After that, the person moves according to their type.

Since data has to be exchanged between persons during these processes and other people's method calls are initiated, the example shows a few ways to do this:

The *ask <object> for <function call>* block is used in the script when looking for neighbors. Because the members of the *neighbors* list can be arbitrary objects, we throw all non-person objects out of the lists. In this case, this can only be a *Graph* sprite. We use the *my <attribut>* block from the *Sensing* palette to ask each object for its name: *ask <item <i >> of <neighbors> for <my <name >>*. A little further down, this is done again in the status query. Again, the *<attribute> of <object>* Block is executed in the context of the other object. Therefore, the blocks are surrounded by a gray ring indicating that the unevaluated code of the block is passed and not its current result.

Directly above, the same happens to the local command *infect*. This is done - as already described - via the tell block.

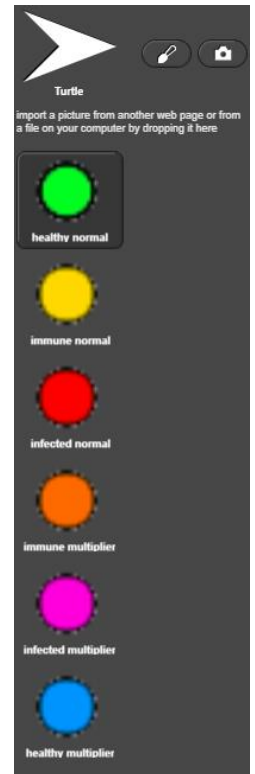

In two places below, local methods - shown in gray - are executed in the context of the object. This happens "normally" when the block is reached.

```

when I receive come on!
  set start time to timer
  repeat until finished?
    set neighbors to my neighbors
    set i to 1
    repeat until i > length of neighbors
      if distance to item i of neighbors > 15 or
        ask item i of neighbors for my name = Graph
        delete i of neighbors
      else
        change i by 1
    set i to 1
    repeat until i > length of neighbors
      if status = infected
        tell item i of neighbors to infect
      else
        if ask item i of neighbors for status of Person = infected
          infect
        change i by 1
      if status = infected and timer - start time > seroconversion time
        set status to immune
        if type = multiplier
          change number of infected multipliers by -1
          change number of immune multipliers by 1
        else
          change number of infected normals by -1
          change number of immune normals by 1
        show yourself
      if type = multiplier
        change x by pick random -100 to 100
        change y by pick random -100 to 100
      else
        change x by pick random -10 to 10
        change y by pick random -10 to 10
    if on edge, bounce
  
```

Blocks for direct communication between objects

```

run
launch
call
tell to
ask for
run w/continuation
call w/continuation
when I start as a clone
create a clone of
a new clone of myself
delete this clone
  
```

The method *infect* infects the current object, if necessary, and changes the appropriate numbers. After that the appearance of the object is changed.

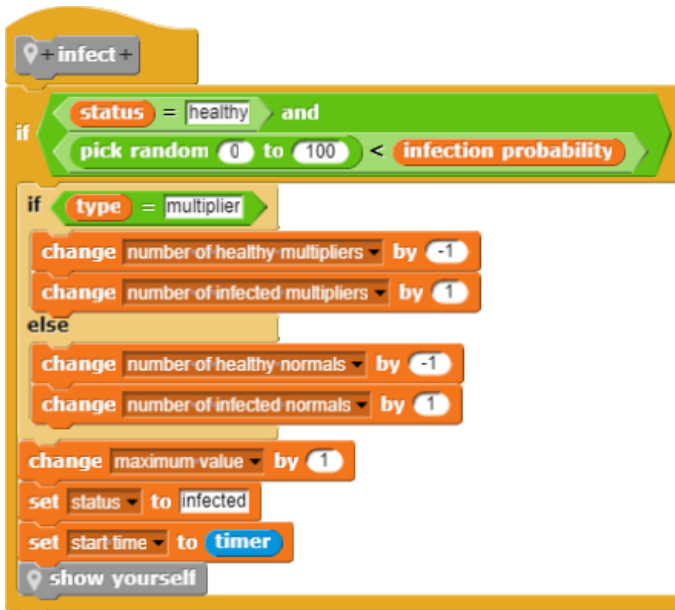

The method *show yourself* select the appropriate costume and determine if there are still infected people left.



2.7.5 Drawing a Diagram

Finally, we want to have our results displayed in a diagram. The initial number of vaccinated (in %) and the maximum number of infected persons (in %) were measured. We create an object for this purpose, which we donate a beautiful pen as a costume. We first have to paint and label a coordinate system on the screen. We find the blocks for this in the *Pen*-palette and (the *label* block) in the *Tools*-Library.

The ascertained data are in list form as variable *data*:

11	A	B
1	0	99
2	3	14
3	7	79
4	10	84
5	13	54
6	17	8
7	20	42
8	23	37
9	27	41
10	30	9
11	33	3

With the helper method and these data the graph can be created: We send the pen to the first data point, given by a list with the two mentioned entries. After that we lead him lowered to the remaining points - with some re-calculation.

```

when I receive show diagram
  script variables i
  draw coordinate system
  if length of data > 0
    pen up
    go to x: -100 + 4 × item 1 of item 1 of data y:
      -50 + 2 × item 2 of item 1 of data
    pen down
    set i to 2
    repeat until i > length of data
      go to x: -100 + 4 × item 1 of item i of data y:
        -50 + 2 × item 2 of item i of data
      change i by 1
  hide
  
```

```

+ draw + coordinate + system +
  script variables i
  switch to costume pen
  set size to 50 %
  point in direction 90
  clear
  pen up
  set pen color to black
  go to x: -100 y: 150
  pen down
  go to x: -100 y: -50
  go to x: 100 y: -50
  set i to 0
  repeat 11
    pen up
    go to x: -105 y: -50 + i
    pen down
    go to x: -95 y: -50 + i
    pen up
    go to x: -130 y: -55 + i
    label i / 2 of size 12
    change i by 20
  set i to 40
  repeat 5
    pen up
    go to x: -100 + i y: -55
    pen down
    go to x: -100 + i y: -45
    pen up
    go to x: -110 + i y: -65
    label i / 4 of size 12
    change i by 40
  go to x: -50 y: -80
  label vaccinated in % of size 12
  go to x: -150 y: 160
  label infected in % of size 12
  
```



The result can be admired on the output area:

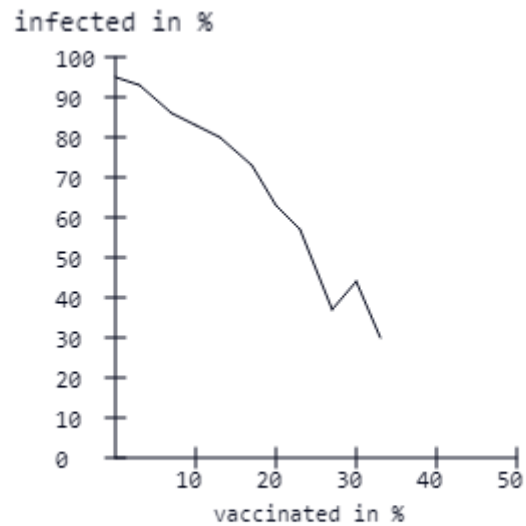

In each case, 300 "persons" were used without multipliers and with only one initially infected (red: infected, yellow: immune, green: healthy). One can see: if half of the population is to remain healthy in this model, then 20% have to be vaccinated.

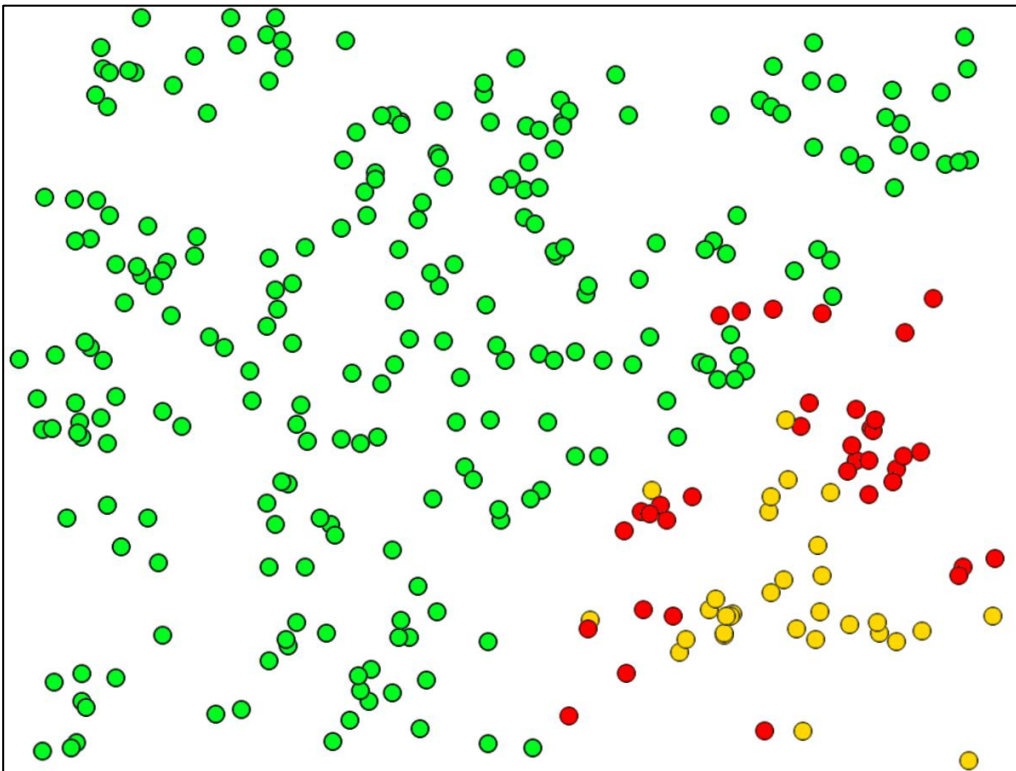

blocks of the Pen palette

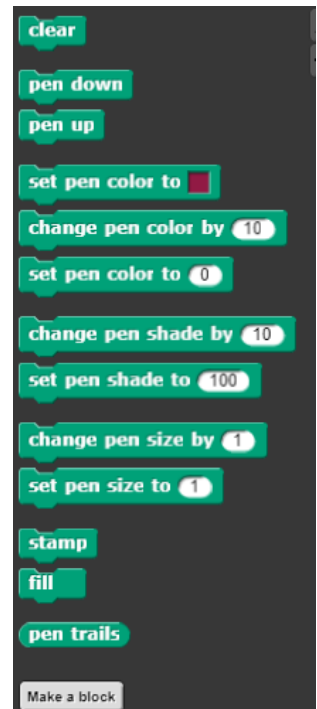

3 Simple Examples

The following examples demonstrate some aspects of *Snap!*. They are quick to implement and should inspire modifications and extensions. Above all, they show how easy is visualization in *Snap!*.

3.1 Swimming

Contents:

- duplicated objects
- communication via messages
- local and global variables

We draw a *swimmer* in three states of swimming (arms elongated or spread, legs bent). These three images additional are mirrored so that the swimmer seems to swim in the opposite direction. Afterwards we draw a swimming pool with pathways as a stage background and look for a costume for a *trainer* in the costumes library of *Snap!*. That's *Cassy* in this case.

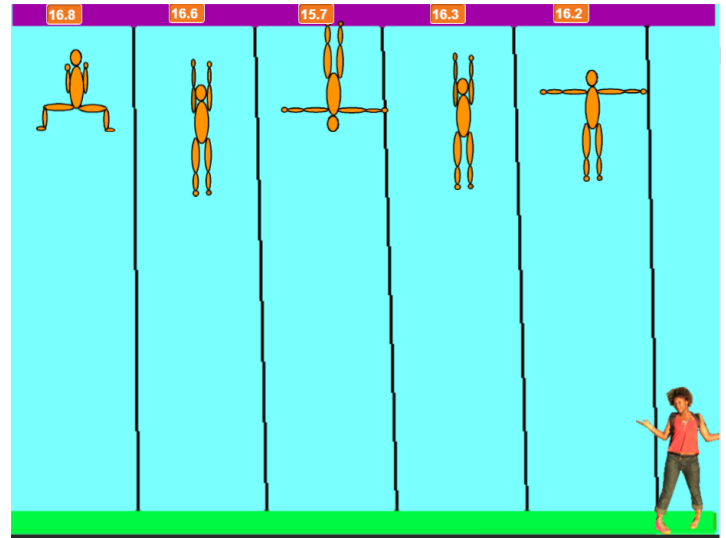

We create two sprites, the first being the *swimmer* and the second the *trainer*. If we click on the green flag, the competition should start. The swimmer goes into starting position on the left lane ($x = -195$). Its x-position is stored in a local variable x , which is different for each swimmer. Everyone swims in his orbit. Since the swimmer is a bit big, we scale him to 40%. He then waits for the start signal.

The trainer is also slightly downsized and is sent down-right to the edge of the pool. There she gives a tip to start the competition. She waits for it too.

Since the blue water is part of the stage, it only receives a single script that responds to a mouse click. The stage then sends the message "*come on!*" only to the trainer. If one uses a two-element list as a message, the first element represents the message, the second the one or more addresses.

After that our trainer sends the message "*start*" to all, notes that the competition has begun, and then jumps around a bit.

```

when clicked
  set size to 40 %
  switch to costume swimmer-close1
  set x to -195
  go to x: x y: -138
  point in direction 90
  set direction to up
  say
  set time to 0

```

```

when clicked
  set size to 50 %
  go to x: 220 y: -130
  switch to costume trainer1
  say click-on-the-water-to-start!

```

```

when I receive come on!
  say
  broadcast start
  set competition is running to true
  forever
    next costume
    wait pick random 1 to 3 secs
    switch to costume pick random 1 to 3

```

```

when I am clicked
  broadcast list come-on! trainer

```

Our swimmer starts with the message "start". He notes his *start time* in a local variable, because afterwards each swimmer measures his own *time*. Thereafter, he periodically changes his costume depending on the direction of the swim and glides a random piece forward a random time. His *direction* is also stored locally, as the swimmers turn around at different times. After the movement, the swimmer shows his new time, measured from the starting time, and checks to see if he should turn back. Then he checks if he is at the finish. If the competition is still running, he is happy because he is the winner. This is indicated by changing the variable *competition is running* and sending out a message. It was created as *global*, since it applies to all participants. In any case, the movement ends at the finish (*stop <this script>*).

If all goes well, then four duplicates of the swimmer are created by right-clicking on its costume in the sprite area and selecting "duplicate" from the context menu. The lanes of the now five swimmers are assigned by specifying the x-value. The time variables of the individual swimmers should be displayed above the tracks. For this purpose, the check mark in the selection box is set in the *Variables* palette. By right-clicking on the variable display (the *monitor*) you can choose different representations. We take "large" and slide the ads across the lanes.



```

when I receive won
  script variables random
  set random to pick random 1 to 3
  if random = 1
    say |I can't believe!| for 10 secs
  if random = 2
    say |That's a result!| for 10 secs
  if random = 3
    say |Well, you never know.| for 10 secs
  
```

```

when I receive start
  set start time to timer
  set time to 0
  forever
    if direction = up
      switch to costume swimmer-close1
      glide pick random 0.1 to 0.5 secs to x: x y:
        y position + pick random 1 to 10
      switch to costume swimmer-long1
      glide pick random 0.1 to 0.5 secs to x: x y:
        y position + pick random 1 to 10
      switch to costume swimmer-wide1
      glide pick random 0.1 to 0.5 secs to x: x y:
        y position + pick random 1 to 10
    else
      switch to costume swimmer-close2
      glide pick random 0.1 to 0.5 secs to x: x y:
        y position + -1 * pick random 1 to 10
      switch to costume swimmer-long2
      glide pick random 0.1 to 0.5 secs to x: x y:
        y position + -1 * pick random 1 to 10
      switch to costume swimmer-wide2
      glide pick random 0.1 to 0.5 secs to x: x y:
        y position + -1 * pick random 1 to 10
  set time to timer - start time
  if touching ?
    set direction to down
  if touching ? and direction = down
    if competition is running
      say won!
      set competition is running to false
      broadcast won
  stop this script
  
```

If someone has won, the trainer comments on this by setting a script variable of the script to a random value and expressing herself accordingly. That's when her prancing ends.

3.2 Solar System¹⁴

Contents:

- multiple objects
- parameters and their typing
- parallel methods

We get a picture of the sun and some planetary images from the net and shrink them a lot. Then we'll load them as costumes into a planet prototype sprite called *Planet*. A second sprite called *Starter* organizes the "creation" of a solar system.

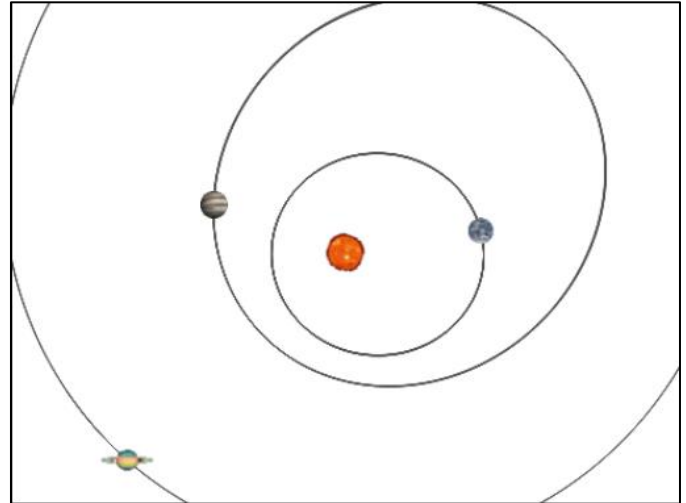

Our planet has a set of local variables describing its state. These includes its mass m , the speed components v_x and v_y , the acceleration components a_x and a_y as well as its distance from the sun r . These values are passed to it by a global method *setup*. We create it using the *Make a block* Button and enter its name. Since the method is to be global, we take the default "for all sprites". Parameters now can be entered for the + characters that appear in the block header next to and between the identifiers. We click the first "+" to the right of *setup* and enter the parameter name x . We could leave it at that, because *Snap!* guesses the type of a value (usually) correctly. But we want to typify the parameters. To do this, click on the small right arrow to the right of *Input name*. An extensive selection window appears. In this we click *Number* to specify that only numbers can be entered as a parameter value. For the next parameters we proceed accordingly with the name typed as *Text*. We get:



As a script of this block we now need to insert code that will send our planet to the right place, take the parameter values into the variables, and select the right costume that results from the planet name. Finally, a local method *move yourself* is started. Because it contains an infinite loop, the program must not "hang" in this loop. Therefore, we start *move yourself* using the *launch* block which creates a parallel process (a new *thread*) and executes it. This allows the program to continue without waiting for an end of *move yourself*. Each planet runs in its own thread.

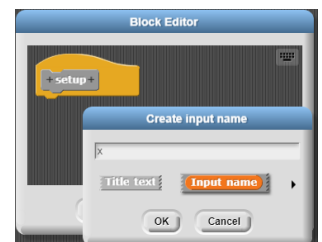
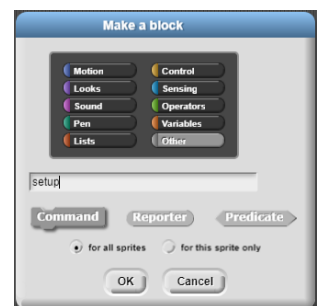

start parallel processes

¹⁴ In a fairly simplified version: The sun stands like nailed in the middle and the planets do not affect each other.

If the sun is in the origin of the coordinate system, then you get the gravitational force on the planet $\mathbf{F} = -G \frac{m \cdot M}{r^3} \cdot \mathbf{r}$ (vectors bold), therefore $\mathbf{a} = -G \frac{M}{r^3} \cdot \mathbf{r}$. From the two acceleration components a_x and a_y we calculate changes of the speed components v_x and v_y and from these changes of the position. This happens again and again in the method *move yourself*.

Now we have to create a new solar system. We clone our planet three times and baptize the clones *Earth*, *Jupiter*, and *Saturn*. This is done using the context menu in the sprite area.

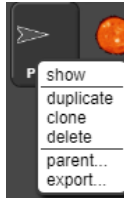

Finally, our *Starter* Sprite comes into play. This stamps a sun image in the center of the coordinate system and starts the three planets by calls to the setup method, which works in the context of the planets with their local values.

```

when clicked
clear
switch to costume Sun
go to x: 0 y: 0
stamp
hide
tell Earth to setup 100 0 0 2.2 Earth 700
tell Jupiter to setup 150 150 -2 2 Jupiter 3000
tell Saturn to setup -200 -100 2 -3 Saturn 2500
    
```

```

+setup+ x # + y # + vxNew # + vyNew # + name + mNew # +
pen up
go to x: x y: y
set m to mNew
set vx to vxNew
set vy to vyNew
switch to costume name
show
pen down
launch move yourself
    
```

```

+move+ yourself+
forever
set i to
sqrt of x position x x position + y position y y position
set ax to -1 x m x x position / r x r x r
set ay to -1 x m x y position / r x r x r
change vx by ax
change vy by ay
go to x: x position + vx y: y position + vy
    
```

All values have been selected so that the trajectory curves at least partially fit on the screen.

3.3 Caesar Encryption

Contents:

- dealing with character strings
- simple typecasting
- blocks as macros
- text output with the tools library
- event handling



We want to encrypt and decrypt simple strings using the Caesar method. Since this is very hard computer science, we also need a very serious, somewhat boring surface. There should be some buttons on it. We import them from the *Costumes* library using the File menu. (As you can see, there are much more "interesting" costumes in the library!) The *button* image is exported to a file. With the help of a graphics program we make it a little bit longer and label it differently. We reimport the resulting costumes. We create three new empty blocks called *text input*, *encryption* and *decryption* and make sure that our buttons respond correct when you click on one of them.

We copy the button twice using the context menu in the sprite area and change the costumes and blocks accordingly. We drag the buttons to the right place, change their names e. g. to *bTextInput*, and remove the check mark in front of the box *draggable*. Now the button is stuck.

Then we create four global variables named *original text*, *ciphertext*, *decrypted text*, and *key*. We show them on the screen with *monitors* (set a tick in front of the variable names) and change to a large representation using the context menus in the display area. After that we pull them to suitable places.

We import the *Tools library* (see above). Here we need only the block *label <text> of size <size>* from the *Pen palette* to label the output. To do this, we create a new sprite named *Control* that provides a very serious interface and changes the variable *key* when the appropriate key is pressed.

We now come to the actual functionality, which can be developed independently of each other. Text input is simple: we ask for the original text. Sure, the output can be made much more beautiful.

```

+ text + input +
ask text? and wait
set original text to answer
    
```

```

when I am clicked
switch to costume button-text-input
set size to 50 %
text input

when up arrow key pressed
change key by 1

when down arrow key pressed
if key > 1
change key by -1
    
```

```

when clicked
hide
clear
point in direction 90
set pen color to black
go to x: -220 y: 100
label TextInput of size 14
go to x: -220 y: 70
label Ciphertext of size 14
go to x: -220 y: 40
label decryptedText of size 14
go to x: -220 y: 10
label key: of size 14
go to x: -220 y: -20
label Change-key-with-up-and-down-keys of size 14
set original text to 
set ciphertext to 
set decrypted text to 
set key to 5
    
```

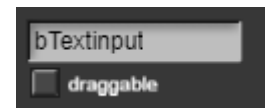

to "nail a sprite"

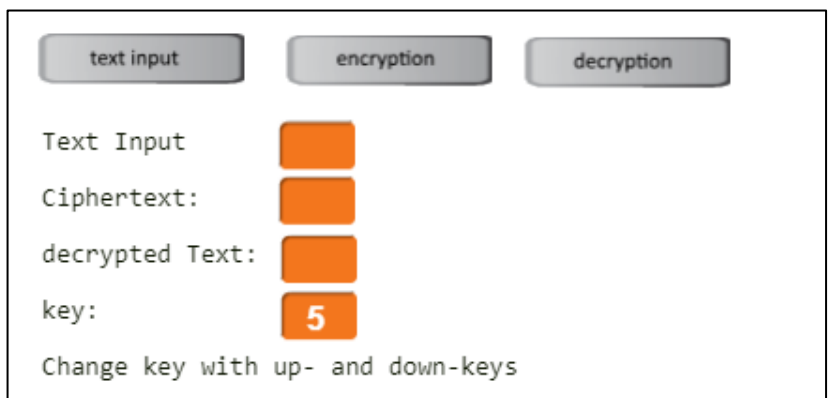

Caesar encryption consists of moving all characters in the code (here: in *Unicode*) by the key length. The last characters are moved forward cyclically. In the adjoining script this is done very verbosely, but - hopefully - legibly. Note that the green *length of <string>* block from the *Operators* palette works with strings, the brown *length of <list>* version from the *Variables* palette works with lists.

The encryption script starts with a '+ encryption +' block. It sets up script variables for 'i', 'char', 'code', and 'cipherchar'. It then sets 'cipherchar' to an empty string and 'i' to 1. A 'repeat until' loop runs while 'i' is less than or equal to the 'length of original text'. Inside the loop, it sets 'char' to the 'letter i of original text' and 'code' to the 'unicode of char'. An 'if' block checks if 'code' is between 96 and 123 (lowercase letters); if true, it changes 'code' by -32. Another 'if' block checks if 'code' is between 64 and 91 (uppercase letters); if true, it changes 'code' by 'key'. A third 'if' block checks if 'code' is greater than 90; if true, it changes 'code' by -26. Then, it sets 'cipherchar' to 'unicode code as letter' and appends it to 'cipherchar'. Finally, it increments 'i' by 1.

The decryption script starts with a '+ decryption +' block. It sets up script variables for 'i', 'char', 'code', and 'cipherchar'. It sets 'decrypted text' to an empty string and 'i' to 1. A 'repeat until' loop runs while 'i' is less than or equal to the 'length of ciphertext'. Inside the loop, it sets 'cipherchar' to the 'letter i of ciphertext' and 'code' to the 'unicode of cipherchar'. An 'if' block checks if 'code' is between 64 and 91 (uppercase letters); if true, it changes 'code' by '-1 x key'. Another 'if' block checks if 'code' is less than 65; if true, it changes 'code' by 26. Then, it sets 'char' to 'unicode code as letter' and appends it to 'decrypted text'. Finally, it increments 'i' by 1.

The decryption is done inversely for encryption.

The screenshot shows a web interface with three buttons: 'text input', 'encryption', and ' decryption'. Below the buttons, the following text is displayed:

- Text Input: **This is a total secret text!**
- Ciphertext: **YMX NX F YTYFQ XJHWJY YJCY!**
- decrypted Text: **THIS IS A TOTAL SECRET TEXT!**
- key: **5**

Change key with up- and down-keys

3.4 Tasks

1. a: Find out about the **XOR encryption**. Implement the procedure.
- b: Find out about **transfer procedures for encryption**. Implement the procedure.
- c: Find out about the **cryptanalysis**. Implement a frequency analysis.

2. In the **camel problem**, the animal is in a terrible situation between three pyramids. It moves purposefully towards a randomly selected pyramid. Once it has travelled exactly half the distance to the pyramid, a hateful desert spirit comes and whirls the poor creature around, so that it no longer knows which pyramid it was driving. The movement, of course, leaves a print on the screen, and the procedure begins anew.

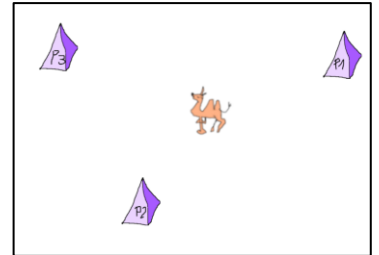

3. The **goat problem** is popping up in the media every once in a while. The point is this: in a raffle there are three doors behind which there is a goat in two, behind the third is the main prize. The game leader who knows the positions asks the player to guess a door. He then opens one of the remaining doors, behind which a goat is located, and offers the player to change one's choice – or not. The question is: Should he do that? Realize the game and decide the question empirically.

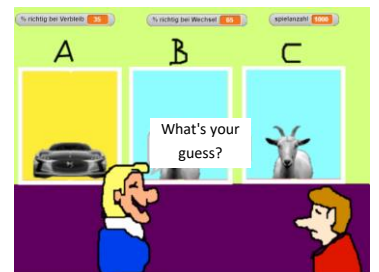

4. a: **Desert ants** live alone in the desert. If they leave their burrow they look for something edible in the area. Once they find this, they run right back to the burrow. Obviously, they remember what movements they have made. From these they calculate the direct way back. Realize the process.

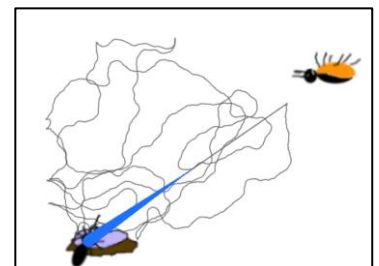

- b: On their way to the burrow, the ants lay a **pheromone trail** that evaporates slowly. On it they find their prey, take another piece and run back to the burrow, laying a new pheromone track. If they haven't found anything, they won't leave a new trail.

5. Two young ladies sit in the **theatre bistro** and get bored. One stands up and goes ... and then the story goes off! But how?



4 Simulation of a Spring Pendulum

In addition to the extensive freedom of syntax, the excellent visualization possibilities and the good-natured behavior of *Snap!* in case of errors are an incentive for the learners to proceed experimentally and test their own ideas. In addition to the analytical top-down procedure, this results in a bottom-up approach of the trial-and-error, which is important for beginning programmers because it allows them to gain experience in this field, which they can systematize later on. Experimental approach opens up opportunities for independent problem solving right at the beginning instead of following given results.

In the field of simulations, including many of the usual games, we find enough simple but not trivial problems which can be solved by beginners with a bit of good will. Experimental work naturally requires an interest in developing one's own ideas. We therefore need problems that generate sufficient motivation. As an example, we choose the simulation of a simple spring pendulum, which hangs on a periodically oscillating exciter. Ok, ok, I already know that an example from physics does not have a very motivating effect on all learners - rather in contrary. But I'm not giving up my hope!

4.1 Organization of Cooperation

If groups work largely independently of each other, it must be clear on the one hand in which framework they work, and on the other hand how the results can be brought together later on.

To create a frame, you can create empty blocks with the correct names as "dummies". These can be used in scripts without any functionality. The required objects can also be created and provided with rudimentary behavior, e. g. in response to events: You can, for example, output a speech bubble with an explanatory text: "*This and that should actually happen now!*" This program frame can be exported and imported as a whole or in parts:

- The project can be exported with all its parts using the file menu. It will appear at the bottom of the *Snap!* window. Clicking on the arrow to the right of it will take you to the download folder where it was saved. From there it can be dragged into any *Snap!* window and opened again.
- If there are global methods (blocks "for all sprites") in the project, another item "Export blocks..." appears in the same menu. If it was chosen, the blocks to be exported can be selected in the window that appears. These can be dragged into open *Snap!* windows like projects.



- Sprites can be exported with their local methods as a whole by selecting the item "export..." in their context menu in the sprite area. The re-import is carried out as described above.
- Within a project, scripts can be transferred from one object to another by dragging them from the sprite where they are located on the script area to the sprite in the sprite area that is to be supplied with the script. The addressee will be highlighted a little bit when "dragging on", if it has noticed that it is meant.



The example of the spring pendulum contains several parts that are largely independent, so that group work is almost unavoidable.

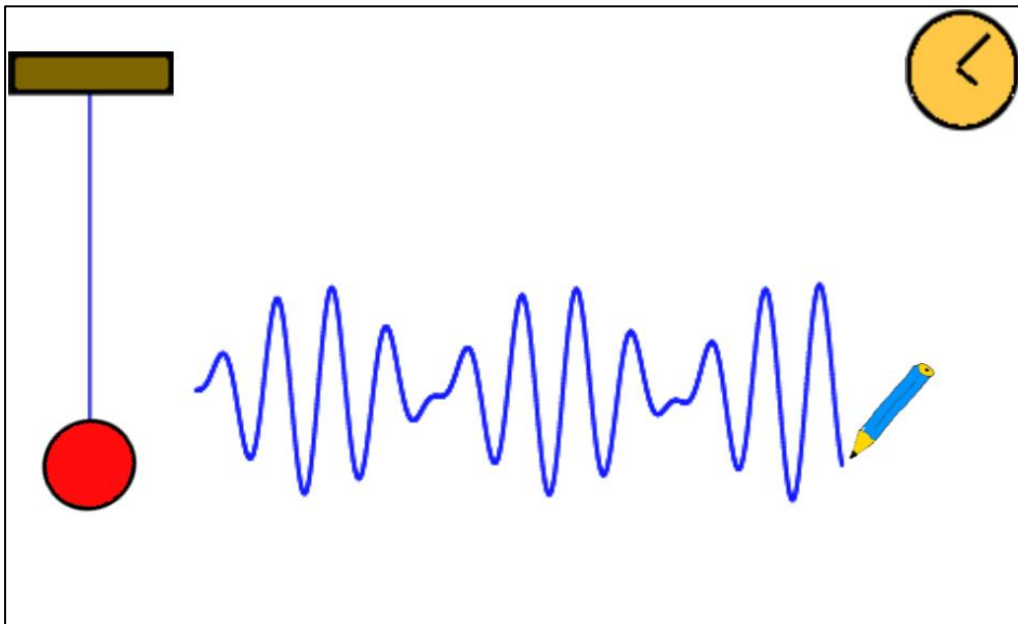

the screen layout

We identify

- an *Exciter*, the dark top-left plate that periodically swings vertically. Its frequency w (instead ω) is an instance variable and can be changed in the variable display.
- a *Ball*, which is relatively stupid on a thread, but understands at least so much physics that it knows the basic equation of mechanics.
- a *Thread* that has to draw itself again and again so that we don't see any protruding ends on the screen.
- a *Pen* recording the motion-time graph of movement.
- a *Clock* for the common time.

4.2 The Clock

We create a new sprite and draw a simple watch as its costume. When clicking on the green flag, we choose this costume for the clock and send it to the top-right corner. After the clock has been started using the start message, it sets the variable t to zero and remembers the time of the timer built into *Snap!* in the variable *start time*. Afterwards, it continuously transfers the past time in seconds into the variable t , which is available to the other sprites as system time. Since the times t and *start time* logically belong to the clock, we choose them as local variables. Local variables can be accessed from other objects via the `<attribute>of <object>` block of the *Sensing* palette. We export the clock sprite as specified to the file *Clock.xml*.



Extension: Let the sprite display the time (minutes and seconds) either "digital" or by moving the pointers correctly.



4.3 The Exciter

We draw a simple rectangle that symbolizes a plate hanging somewhere. Since the plate should only swing vertically, it needs a fixed x -coordinate on the screen (here: -200) as well as a resting y -position (here: 150). Around these it oscillates with a fixed amplitude (here: 10) with a variable circle frequency ω (here: 150). With help of the time t that initially has a value of zero, the y -coordinate is calculated to

$$y = 150 + 10 \cdot \sin \omega t.$$

This information can be translated directly into a script.

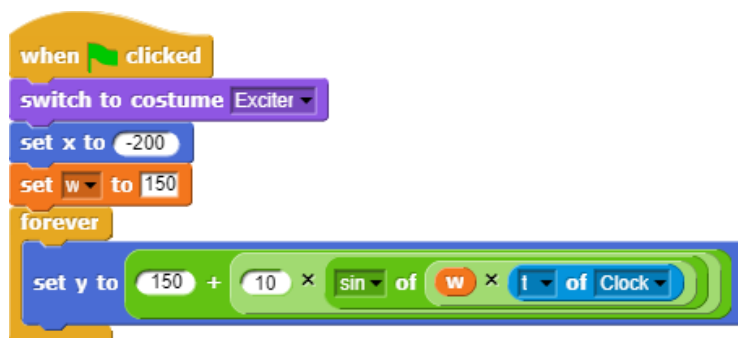

The script starts to work when the *Go-message* (click *green flag*) is sent. Since the scripts of the other parts have to be started at the same time, this option is sensible.

The variables used are more interesting. The time is imported by the clock. The frequency is not required in any other script and should therefore be created locally. You can change them using the arrow keys.

We export the sprite as described as *Exciter.xml*.



Extension: Let's also draw the "laboratory ceiling" against which the exciter swings. Alternatively, a roll can rotate, which leads to a vertical periodic movement via a pulley.

4.4 The Thread

The thread replaces the coil spring. It has only one characteristic, the spring constant D . This is set once to a fixed value, then a bright vertical line is drawn at the location of the thread, which deletes its old representation (which of course could be done more elegant). Then the current line from the ball to the exciter is drawn. We export the object as *Thread.xml*.

Extension: Instead of a simple string, draw a spiral spring with a constant number of coils stretching and retracting.

4.5 The Ball

Our physical knowledge is "incorporated" into the ball, which can be rather flimsy: we know the basic equation of mechanics $F = m \cdot a$ as well as Hooke's law $F = D \cdot s$, with s the distance from the zero position. Furthermore, the acceleration a is the change of speed per unit of time and v is known as change of position per unit of time. Nothing else. We translate this knowledge into a sequence of commands: We determine the current deflection s , from this F , from this a , resulting v and from this the new position.

We export the ball as *Ball.xml*.

Extension: Introduce a friction constant R that decreases the speed by a certain (small) percentage. R can also be changed interactively in a meaningful way.

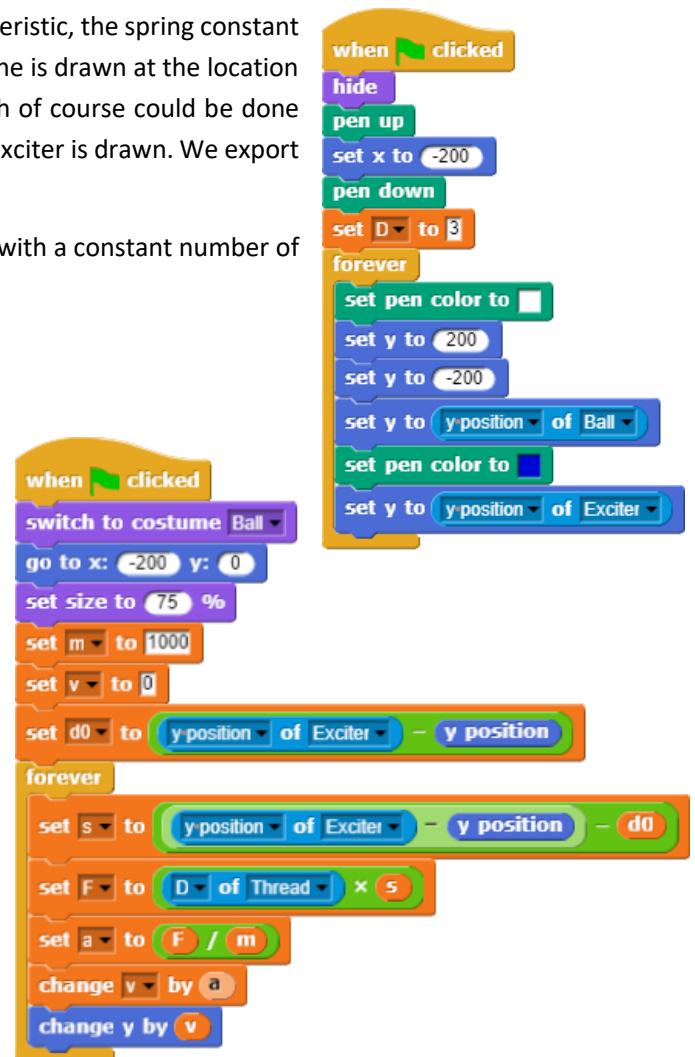

4.6 The Pen

The pen does not have any local variables. It travels slowly from left to right and moves in the y -direction to the y -position of the ball. It writes. We add as a small delicacy the function that it starts to re-write when it reaches the right margin.



```

when clicked
  point in direction 90
  set size to 50 %
  go to x: -150 y: y-position of Ball
  clear
  pen down
  set pen color to blue
  set pen size to 2
  forever
    go to x: x position + 0.2 y: y-position of Ball
    if x position > 200
      go to x: -150 y: y-position of Ball
      clear
  
```

We export the sprite as *Pen.xml*.

Extension: Enter a way for the stylus to derive its x position directly from the system time. It should also be able to run at different speeds.

4.7 Why is it a simulation?

Our example contains some basic knowledge of physics, but there is nothing to be found in it about resonance, beatings etc. With the program, we check whether the *necessary consequences* (according to Heinrich Hertz) of the basic knowledge agree with the observations in the experiment, i.e. whether our ideas of physics result in the observed behavior. We're simulating a system to check our imaginations. Instead of mathematics, we use an algorithm that tracks system behavior over a sequence of small temporal changes. So instead of integrating "mathematically", we iterate "informatically". However, except of the simple cases a tool for the integration of a differential equation system does nothing else.

Something completely different is an *animation* in which the observed behavior is programmed. No new phenomena can arise here, because everything is known. Animations present something, *simulations* can lead to real surprises.

5 Troubleshooting in Snap!

Snap! visualizes the program flow without requiring special activities of the learners. This alone makes many errors "visible", which would otherwise require the laborious analysis of code to find them. For example, if a body moves in the wrong direction, then it is quite clear what to look for.

Since global and local variables can be displayed on stage by ticking the checkboxes in front of the variable name in a *monitor*, their change can be observed directly. Script variables can be displayed in the same way if the *show variable <name>* or *hide variable <name>* blocks are built into the script. An essential aspect of troubleshooting is the "freezing" of the variable assignments at a program stop: if you end the program, the current values of the variables are retained and can be inspected.

Control outputs during program execution can be easily accessed using the *Looks* palette blocks: *say <something> for <n> secs* and its relatives also allow more complex expressions to be output, so they can be tracked on the screen. The *wait <n> secs* and *wait until <condition>* blocks enable pauses in the program flow at certain points and/or when certain conditions occur.

If the process of the entire programme is to be followed gradually, then the *Visual Stepping* must be turned on (at the top of the output window).



After that, the footsteps will appear light green, and next to them a slider will appear that determines the pace. A button appears between the green flag and the red stop button to interrupt or start the stepping process. If the speed controller is on the far left, the program can be run through in single steps. The currently executed block appears light green.

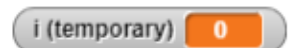
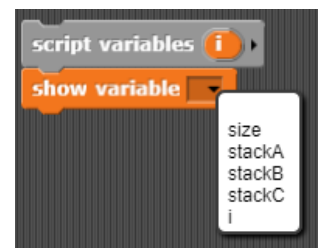
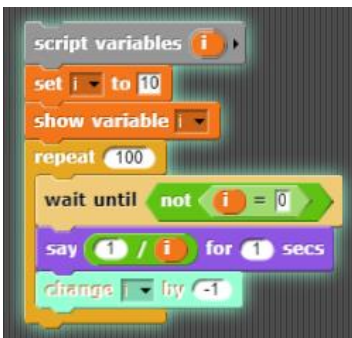
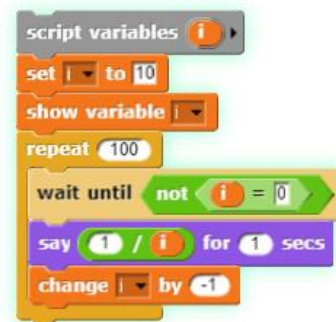

Monitors of a global list, a local sprite variable, and a script variable.

If the program execution is to be followed within the own blocks, then these must be opened before starting the program. The blocks can also be nested.

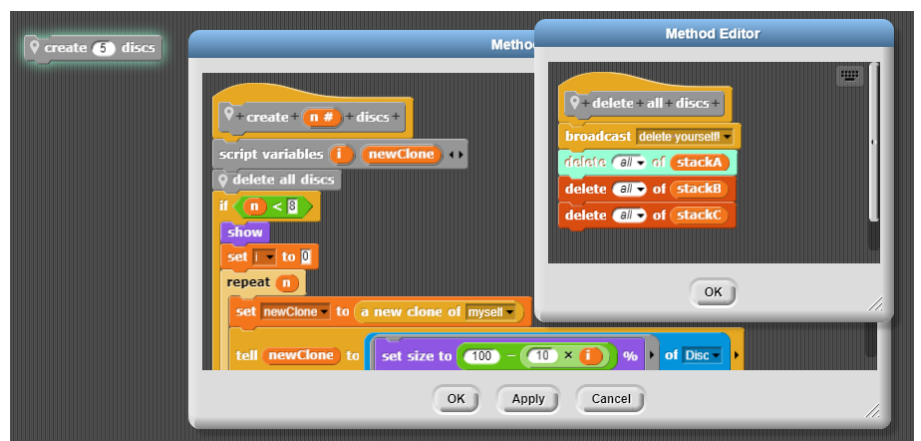

We want to follow the processes with a small example. For whatever reason - the problem of the "Towers of Hanoi" should be dealt with. Therefore we draw a disc and assign this costume to a sprite *disc*. Further discs are to be produced by cloning. We have written a method for this - but it does not work. Too bad!

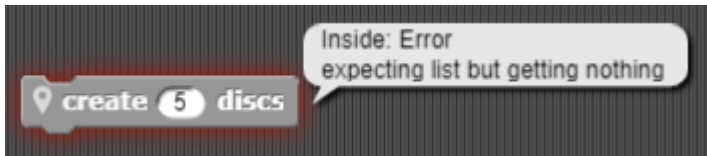

To locate the error, we open the method in the editor, click on the *Visible Stepping* button, set the desired speed and then click on the new block again. In the editor we can track the commands called - and where it goes wrong.

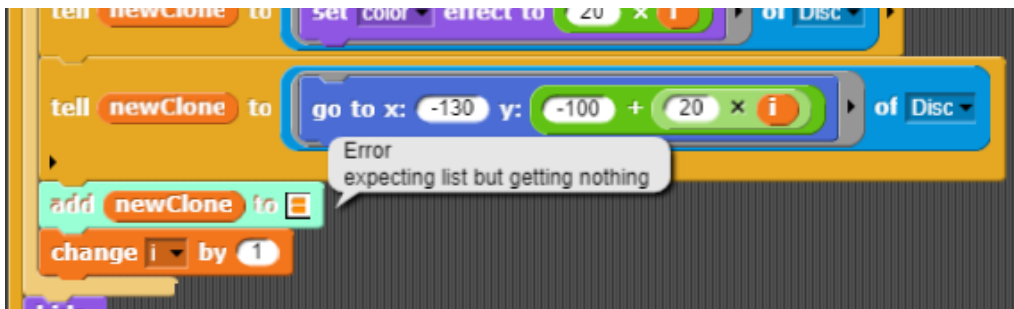

There's something missing!

Other blocks that can be helpful in troubleshooting are found in the libraries. They are described by their own help pages, which are accessed through their context menus.

For me, the most important way to search for errors is to remove blocks from the scripts and "just let them lie" next to them. If a script works after that the blocks can be inserted again one after the other. In most cases the error can be narrowed down quickly.

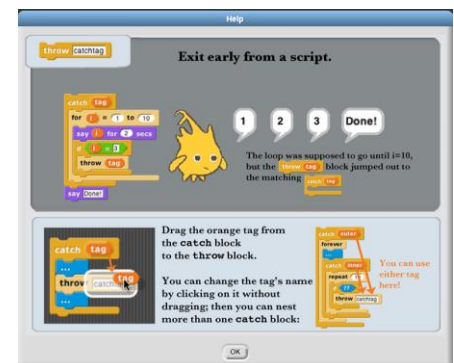

6 Lists and Related Structures

Contents:

- elementary handling of lists
- sort
- more complex applications

In addition to atomic data types such as *numbers*, *boolean values* and *characters*, *Snap!* knows the structured types *string* and *list*. Strings are described later in this book because they allow many applications. This section deals with lists because they are practically always needed. All higher structures can be built up easily with them. The use of lists is first shown in a simple case - sorting, followed by more complex applications.

6.1 Selection Sort

The example is extremely simple: it uses only global variables and blocks without parameters, i.e. macros that serve to combine a command sequence under a new name. Since it also takes advantage of the visualization possibilities of *Snap!*, it is a very good introduction example in lessons.

We start with an empty *Snap!* project. If we want to sort something, the elements to be sorted must be stored somewhere. For this purpose, there are variables, which can be imagined as "boxes" that can hold any content. For saving several elements there are lists, a kind of "row of boxes". The blocks for editing variables and lists can be found in the *Variables* palette.

By the way: The magnifying glass for searching in the upper right corner of the palettes shows us candidates for blocks corresponding to the search pattern. Among them we find blocks written by ourselves and some that are not in the palettes at all.

So, we create a variable called *unsorted numbers* and assign an empty list to it. (With the arrow keys in the list block we could also enter initial values.)



If the variable is displayed, it appears in the output window. There we can choose different presentation forms in the context menu or we place the list as a *dialog* anywhere in the *Snap!* Window. In the same way, we create a second list of *sorted numbers* that will later store the sorted data

First of all, we need unsorted data – as usual random numbers.

We create it with a small script. The number of random values is determined by the number of repetitions in the loop.

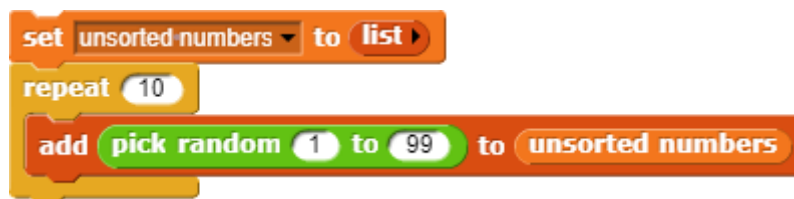

We test the script several times - time and again we get a new number list. Great! We proudly create a new block called *generate new numbers*. (Right-click on the script area.) In this one we simply append our script to the "hat" with the block name. Done - we have written a new command! We can find it at the bottom of the *Variable* palette - if we didn't specify anything else.

From this list of numbers, we want to select the smallest number. To do this, let's assume that the first number is the smallest. Afterwards we will look at all the following figures. If one is smaller than the previous smallest number, we will remember it. If we are through, then we "report" the result - we write a function *get the smallest number*.

It works great, too. However, only once, because we can't find the next smaller number in this way. This is only possible if we remove the smallest one from the list every time. Because we only know which was the smallest number after the entire run, we remember not only its value but also its position - and throw it out after the run through the list.

Sorting a list now is very easy: We get the smallest number from the unsorted list and put it in the sorted, one after the other. Ready. The script is packed again in a new block. We call it *Selection Sort*.

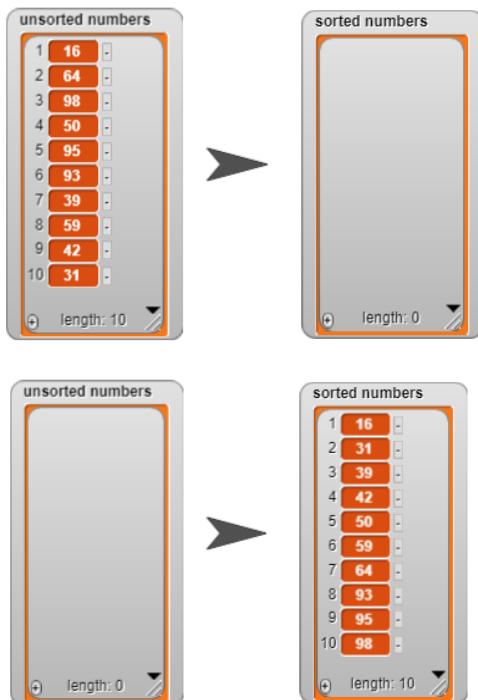

```

+generate+ new + numbers +
set unsorted numbers to list
repeat 10
add pick random 1 to 99 to unsorted numbers
    
```

generate new numbers

```

+ get + the + smallest + number +
set smallest number to item 1 of unsorted numbers
set i to 2
repeat until i > length of unsorted numbers
if item i of unsorted numbers < smallest number
set smallest number to item i of unsorted numbers
change i by 1
report smallest number
    
```

```

+ get + the + smallest + number +
set smallest number to item 1 of unsorted numbers
set position to 1
set i to 2
repeat until i > length of unsorted numbers
if item i of unsorted numbers < smallest number
set smallest number to item i of unsorted numbers
set position to i
change i by 1
delete position of unsorted numbers
report smallest number
    
```

```

+ Selection + Sort +
set sorted numbers to list
repeat length of unsorted numbers
add get the smallest number to sorted numbers
    
```

6.2 Quicksort

As a second, recursive example we want to realize Quicksort¹⁵ in the same environment as above. To do this, we'll first write a more elegant method for creating new numbers using a parameter and local script variable. This allows us to indicate how many numbers we want.

`set numbers to generate 10 new numbers`

Quicksort is started by specifying the list to be sorted.

The actual work is done in the *block divide and arrange the list <list> between <left> and <right>*. As pivot element we select the middle of the respective partial list.

Table view	
10	items
1	72
2	4
3	88
4	24
5	26
6	98
7	81
8	90
9	41
10	61

→

Table view	
10	items
1	4
2	24
3	26
4	41
5	61
6	72
7	81
8	88
9	90
10	98

```

+ generate + n # + new + numbers +
script variables result
set result to list
repeat n
  add pick random 1 to 99 to result
report result
quicksort numbers
  
```

```

+ quicksort + list : +
divide and arrange the list list between 1 and length of list

+ divide + and + arrange + the + list + l : + between + left # + and + right # +
script variables li re pivot h
set li to left
set re to right
set pivot to item round (left + right) / 2 of l
repeat until li > re
  repeat until
    item li of l > pivot or item li of l = pivot
  change li by 1
  repeat until
    item re of l < pivot or item re of l = pivot
  change re by -1
  if re > li or re = li
    set h to item li of l
    replace item li of l with item re of l
    replace item re of l with h
    change li by 1
    change re by -1
  if left < re
    divide and arrange the list l between left and re
  if right > li
    divide and arrange the list l between li and right
  
```

¹⁵ The procedure can be found in various versions on the Internet, e. g. at <http://de.wikipedia.org/wiki/Quicksort>. An in-place implementation was selected here.

6.3 Routing with Dijkstra Method

A graph is given by an *adjacency list*. In this all nodes of the graph are listed. From each node a list "goes off" with the neighboring nodes and the respective distances: that is, those nodes to which a direct connection exists. Examples are a very simple graph and its adjacency list.

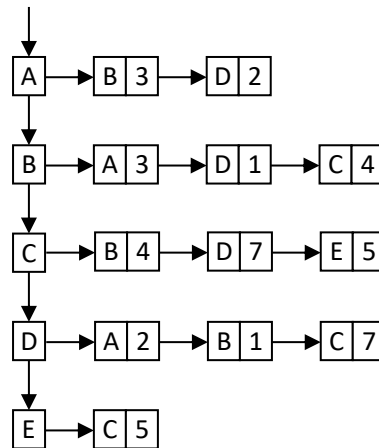
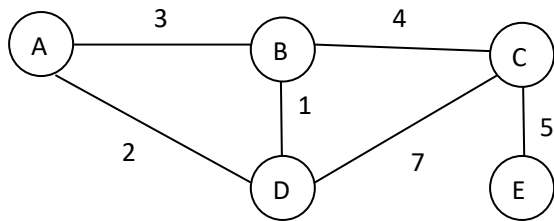

To solve the problem, we need a specialist: we draw Mr. D. He must be able to generate the adjacency list of a given graph. The graphs are simply drawn on the background - here very tastefully done.

We create the list statically by adding the corresponding elements to a local list, which we return as result of the operation.

```

+ new + adjacency + list +
script variables a
warp
set a to list
add list A list list B 4 <> list C 7 <> list D 8 <> <> <> to a
add list B list list A 4 <> list C 2 <> list E 9 <> <> <> to a
add list C list list A 7 <> list B 2 <> list D 2 <> list F 2 <> <> <> to a
add list D list list A 8 <> list C 2 <> list F 1 <> list G 1 <> <> <> to a
add list E list list B 9 <> list H 5 <> <> <> <> to a
add list F list list C 2 <> list D 1 <> list H 3 <> <> <> <> to a
add list G list list D 1 <> list H 1 <> <> <> <> <> to a
add list H list list E 5 <> list F 3 <> list G 1 <> <> <> <> to a
report a
    
```

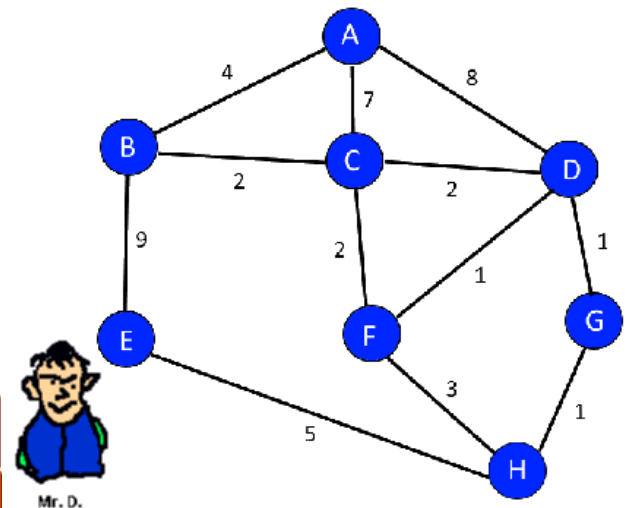

entering nodes and edges as sub-lists in another list

The global variable *adjacencyList* receives these values via a simple assignment.

```
set adjacencyList to new adjacency list
```

For further processing we need three other lists: The list *openTuples* includes tuples that contain the name of the node, its total distance from the start node, and the name of the predecessor node; the list *distances* includes tuples that contain the name of the node and its total distance from the start node, it is sorted anew each time something is added, so the node with the shortest distance from the start is in front; the list *finishedNodes*

contains the names of the nodes that have already been finished. The setup of these lists for the startup is summarized in a *preparation* method, which also transfers the name of the start node. After you have called it, you'll find the following situation:

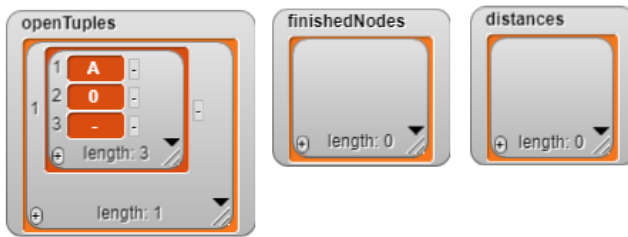

The searching process is very simple in this version, because most of the "intelligence" has been put into the handling of the lists. This is done in the method *step*.

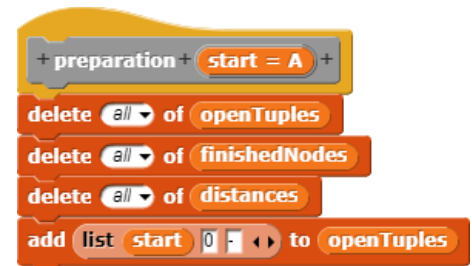

For the tuple *currentTuple* with the smallest distance, the new distances are calculated for the neighboring nodes.

The node is marked as edited and all unedited neighbors with new total distance and predecessor nodes are entered in *openTuples*.

This list is sorted by distance and tuples with larger distances are deleted.

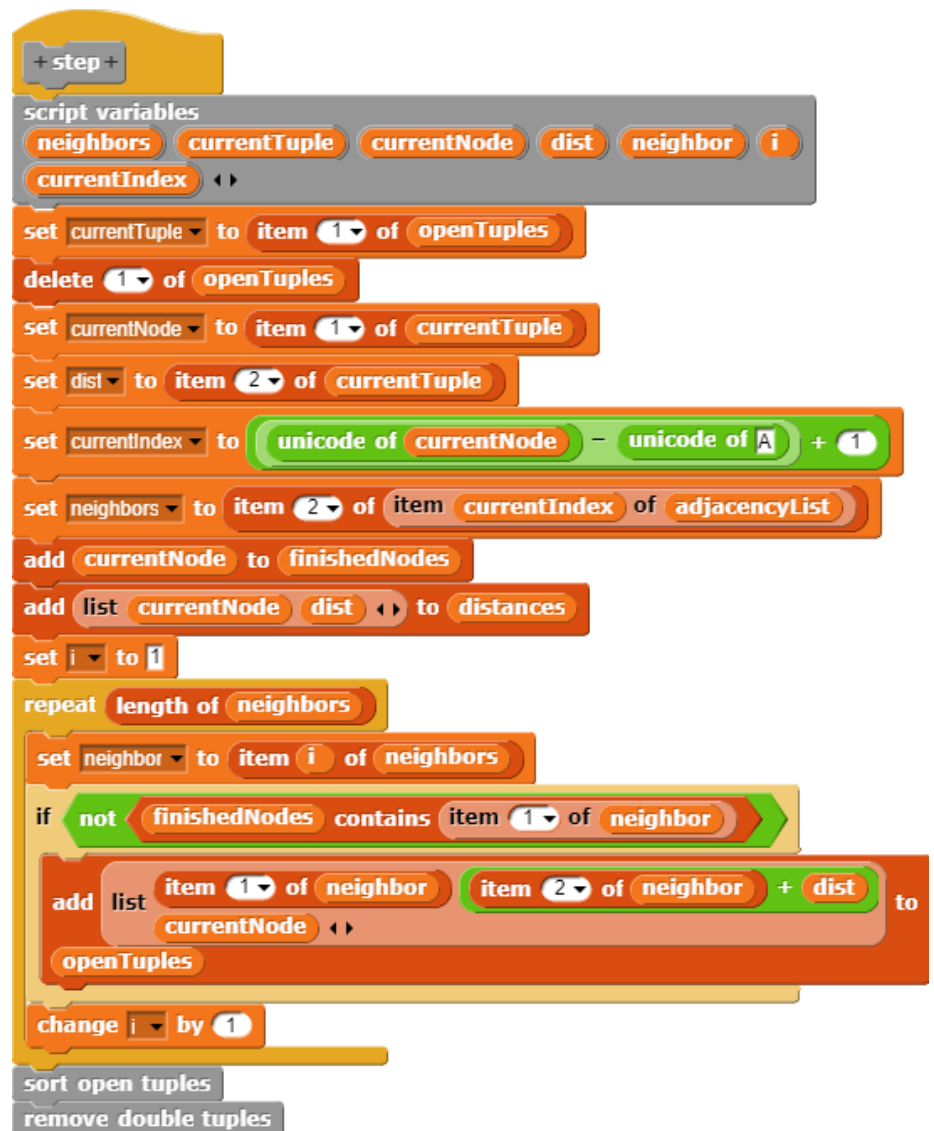

How to sort, we have seen above. Here it is done by selecting the smallest item.

```

+ sort + open + tuples +
script variables sortedTuples i min pos
set sortedTuples to list
repeat length of openTuples
  set min to item 2 of item 1 of openTuples
  set pos to 1
  set i to 2
  repeat length of openTuples - 1
    if item 2 of item i of openTuples < min
      set min to item 2 of item i of openTuples
      set pos to i
    change i by 1
  add item pos of openTuples to sortedTuples
  delete pos of openTuples
  delete all of openTuples
  repeat length of sortedTuples
    add item 1 of sortedTuples to openTuples
    delete 1 of sortedTuples

```

the list *sortedTuples* takes up the sorted tuples

assuming that the smallest distance comes first

find even smaller distances if necessary

add the tuple with the smallest distance to *sortedTuples* and delete it in *openTuples*

copy back the sorted list

```

+ remove + double + tuples +
script variables k i j
set i to 1
repeat until i > length of openTuples
  set k to item 1 of item i of openTuples
  set j to i + 1
  repeat until j > length of openTuples
    if item 1 of item j of openTuples = k
      delete j of openTuples
    else
      change j by 1
  change i by 1

```

Now for each node the tuple with the smallest distance is at the top of the list. If other tuples occur for this node, they are deleted.

Finally, we must select the distance to the searched node and let Mr. D. display it.

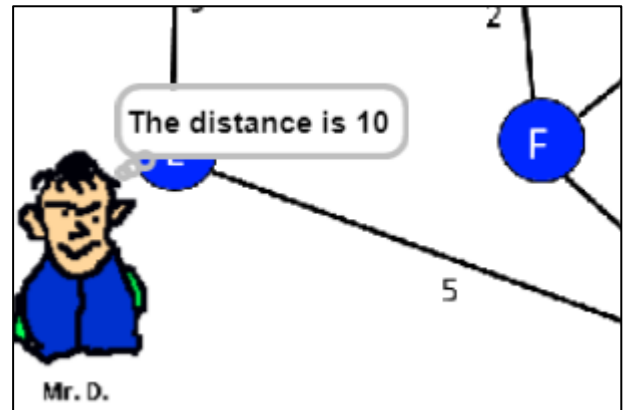
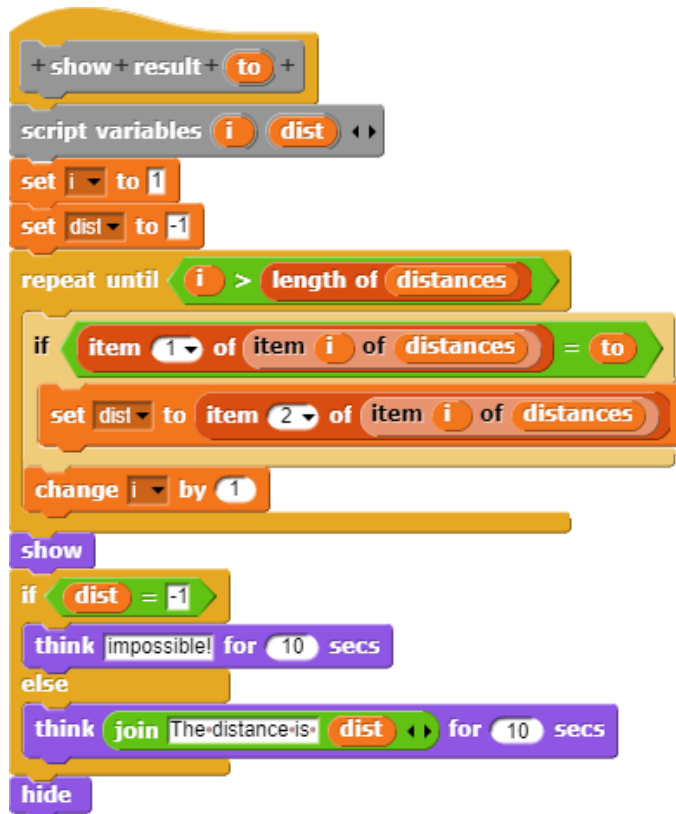

Mr. D.'s gonna find out!

6.4 Matrices and FOR-Loops

If we have lists with direct access to each element, then we don't need any special arrays, stacks, queues, etc. of our own accord. All higher data structures can be built from lists. Nevertheless, we are still working on the data structure *matrix* because it is traditionally used, for example, in the adjacency matrices. (*Attention: for the sake of brevity, we waive all security questions!*)

Of course, we pack a matrix in a list. For this purpose, we agree on the following list structure (arbitrarily):

[[list with sizes of index ranges] [list with data]]

The dimension of the matrix is derived directly from the entries in the first sub-list. A two-dimensional sequence with two values per line would have the following structure:

[[2,3] [1,2,3,3,4,5,6]]

We create a two-dimensional matrix of the size $a \times b$ by creating the two desired lists. The first contains the two passed parameters, the second one should be marked as empty, e.g. with a minus sign. We return the result. We use global methods.

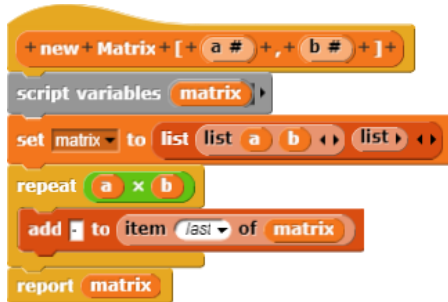

Now we can write values with *set* into the matrix, nice and clear. We first get the dimensions and determine the width of the matrix. Then we calculate the position of the place to be changed and overwrite the corresponding list entry. The *get* method is used to read matrix entries.

The syntax can be chosen freely, with parentheses, if you like!

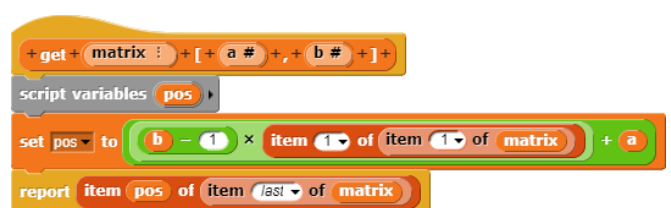
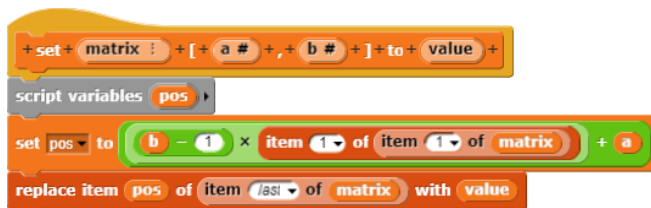

In many programming languages, the counting loop is the most common tool for passing through matrices. In *Snap!* we find something like this in the *Tools* library, but we can write such a control structure ourselves. To do this, we create a new block *for <counting variable> from <start> to <end> step <step> do <script>* and take a closer look at the type of parameters.

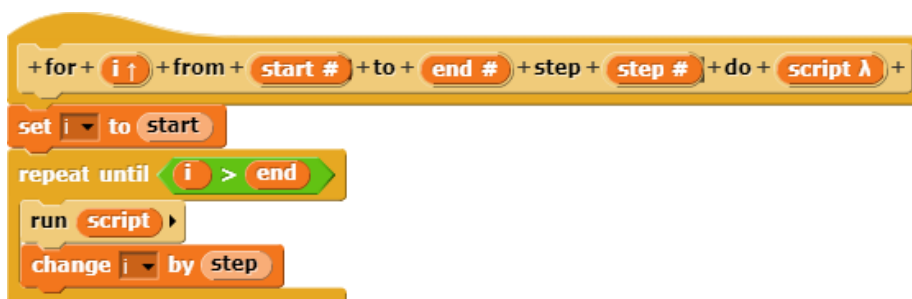

Write your own control structure.

We mark the counting variable *i* as *upvar*. This allows you to change its name "externally", even though its internal name remains the same - *i*.

start, *end* and *step* are normal number parameters.

We mark the *script* as *C-shaped command*. This means that it is regarded as a command sequence that is transferred to the block unchanged, i.e. it is not evaluated.



C-shaped makes sure that the block gets the usual appearance of *Snap!* commands, where the command sequence to be executed is inserted into the "mouth" of C.

Using this loop method, we can quickly fill a matrix with random numbers.



Finally, we want to display the matrix "decently" on the screen, i.e. in the usual two-dimensional table form. To do this, we create a list that is filled with sub-lists, the rows of the matrix, that contain the table data. This list is displayed and can be moved anywhere as a *table view*.

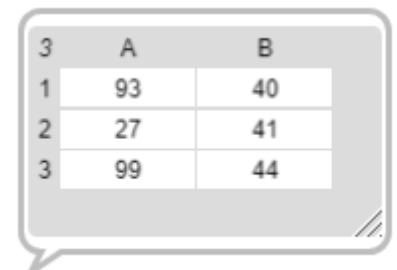
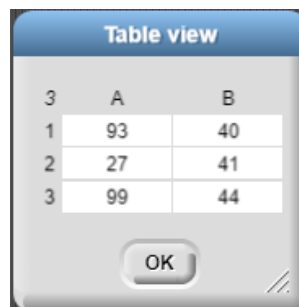

6.5 Tasks

1. Find out on the net about the various **sorting methods**. Implement some of them like *Shakersort*, *Gnomsort*, *Insertionsort*, ...
2. Complete the specified methods in such a way that **incorrect entries** are intercepted.
3. Implement matrices **differently** by structuring the used lists differently.
4. a: Find out more about the data structure **dictionary**.
b: Implement the structure with appropriate operations.
5. a: Implement the data structure **stack**.
b: Implement the data structure **queue**.
6. Implement a simple **binary tree** with the operations
 - a: new tree
 - b: insert <element> in <tree>
 - c: count elements of <tree>
 - d: is <element> existent in <tree>?
 - e: delete <element> from <baum>
 - f: determine the maximum depth of <tree>
 - g: balance <tree>
7. Implement other **control structures**:
 - a: do <script> until <predicate>
 - b: while <predicate> do <script>
 - c: case <variable> of < [[value1,script1], [value2,script2], [value3,script3], ...] >

7 Object-Oriented Programming

OOP methods have also been used up to now - because there is hardly any other way. At this point the OOP possibilities of *Snap!* will be explained in more detail. Please refer to the *Snap! Reference Manual*, which provides a concise explanation of the procedures. You can find it by clicking on the *Snap!* icon at the top-left.

The blocks that are important for the OOP can be found in the *Control-* and *Sensing* palette, but also the context menu in the sprite area has to be considered. The lower blocks of the control palette are used for "dynamic" management of sprites, the menu for "static". This difference is important because it is assumed that only the static clones should be permanent, the others are deleted when you save and are not even displayed in the sprite area.

Snap! works with objects called *sprites* all the time, of course. They have their own attributes (e. g. position, direction, costume, etc.) which can be accessed with the help of different blocks. The *my <attribute>* - block delivers the whole palette, the *<attribute> of <sprite>* - block knows the most important ones and displays the local variables and methods of a sprite.

To select a local method, we place the prototype of the object on the right side of the *<attribute> of <sprite>* block and then select the desired method. The block returns the *code* of the method, which can be recognized by the grey ring around the method name. We execute this code in the context of a sprite that has something to do with the code: usually the prototype, a clone or a copy of it. This can be done using several blocks, e.g. *ask*:



Using the *clone* command from the context menu of a sprite (see above) we can create additional static clones. These are distributed randomly in the output window. Dynamic cloning also creates new sprites, but all at the same place. If you save the project and reload it, the statically generated clones are re-created, the dynamically generated clones are not.¹⁶

An essential aspect of the OOP is inheritance. In *Snap!* this is based on Lieberman's delegation model¹⁷, which works with prototypes (i. e. concrete objects, non-abstract classes) and clones and modifies them if necessary. We will first illustrate all the procedures using simple examples, after that more complex ones.

An essential aspect of the OOP is inheritance. In *Snap!* this is based on Lieberman's delegation model¹⁷, which works with prototypes (i. e. concrete objects, non-abstract classes) and clones and modifies them if necessary. We will first illustrate all the procedures using simple examples, after that more complex ones.

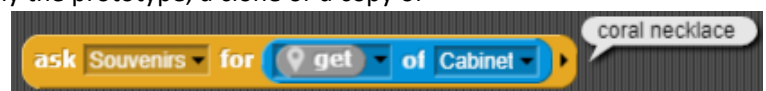
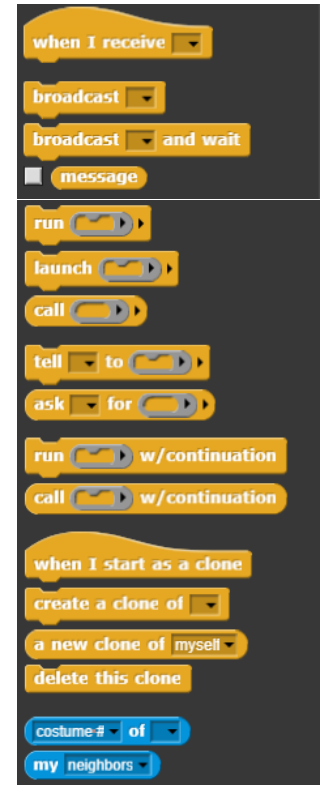
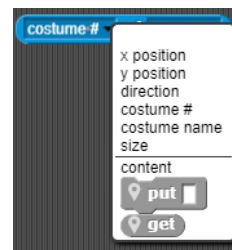

¹⁶ This is a real advancement: with many clones, it is often tedious to get rid of them without destroying the project.

¹⁷ Lieberman, Henry: Using Prototypical Objects to Implement Shared Behavior in Object Oriented Systems, ACM SIGPLAN Notices, Volume 21 Issue 11, Nov. 1986

7.1 Anne and the Filing Cabinets

Contents:

1. prototypes, copies and clones
2. static creation of clones
3. accessing local methods





We draw the costume of an elegant chest of drawers and create a sprite of this name. The chest of drawers contains a local list variable as a data store, which we represent through this same chest of drawers. We provide them with local access to the data by implementing the methods *put*

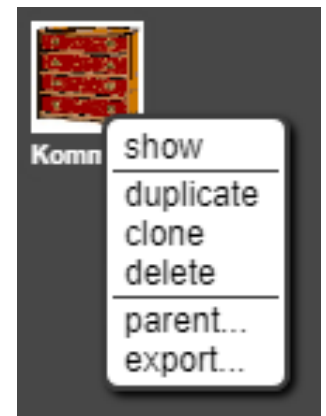
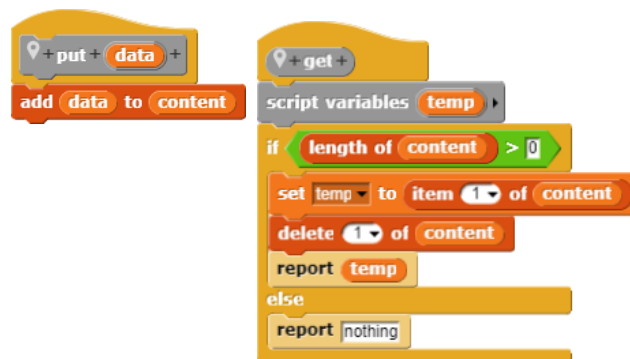
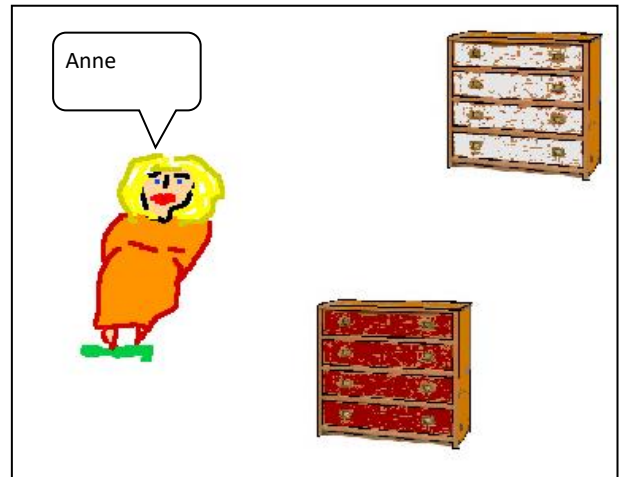

<data> and *get*. This results in a simple queue. We can write any content into the list and remove it from it. Both methods and the variable are indicated by the *<attribute>* of *<sprite>* block.

We want to use two of these data stores. We can either make copies or clones of the prototype. In the case of copies, the contents of the list are also copied so that we have several lists. For cloning, a reference to the list is generated, so insert operations, for example, all affect the list of the prototype. You can see this by the brighter representation of the variable block. To obtain independent lists, we must break this connection after cloning, for example by resetting the list: *set <content> to <list>*. We decide to make copies and create two of them, the sprites *Papers* and *Souvenirs* with slightly changed costumes. For these we need external access.

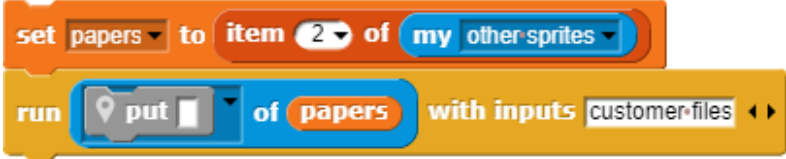

We get help from the IT representative *Anne*. Anne can see the existing methods on other sprites, but how can she access the data stores? There are several options available in *Snap!* for this purpose, both for *Commands* and *Reporters*.

Find another sprite's method:	
<ul style="list-style-type: none"> - Select Sprite (prototype if necessary) in the right input field:  - Select method in the left input field:   <p>The call yields the code of the method:</p> 	
Run a local method of another sprite:	
Parameters are passed in sequence in the fields after " <i>with inputs</i> ". They are inserted in the spaces of the method header if it is clear which method is executed at all.	
Commands	
with <i>tell</i> :	<p>Anne transmits the method header with the corresponding parameter values (here: <i>coral necklace</i>) to the object in question (here: <i>Souvenirs</i>). The called object follows <i>tell</i>.</p> 
with <i>run</i> :	<p>Anne stores the object to be called in a variable (here: <i>papers</i>). She requests this object to execute the transmitted method with the corresponding parameter values (here: <i>customer files</i>). The called object is named in the input window of the <i>of</i> - Block.</p>  <p>Important: First the method must be selected by specifying a suitable prototype as object. Afterwards the variable can be inserted!</p>
with <i>launch</i> :	like <i>run</i> , but the script is executed as a separate process, i.e. without waiting.

Reporter	
with <i>ask</i> :	<p>Since it is a call to a reporter method (a function), a value is returned. Possible parameters are transferred as described above. The called object follows <i>ask</i>.</p> 
with <i>call</i> :	<p>Comparable to <i>run</i>. Again, the called object is called as a second input.</p> 

If attributes of another sprite are to be changed externally, this can be done as usual using a *set* method. But it also works directly: we execute the *set <variable> to <value>* block in the right context:



And of course we can call the standard blocks.



Anne, as a well-trained IT representative, of course can issue such commands, but a normal user cannot. Anne therefore makes new global blocks available, which have the additional parameter of the filing cabinet to be used. This greatly simplifies use throughout the entire system. Anne is happy.

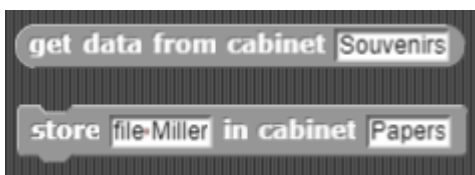
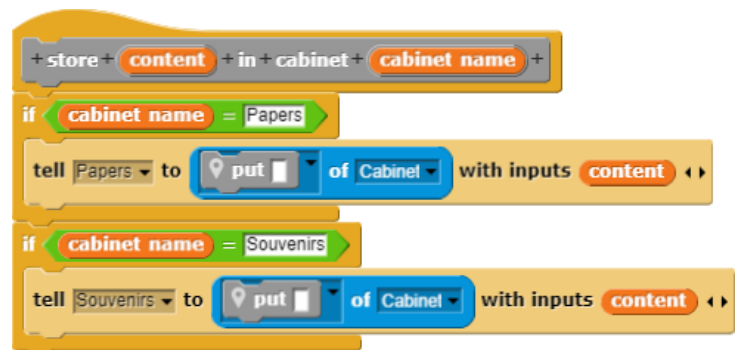
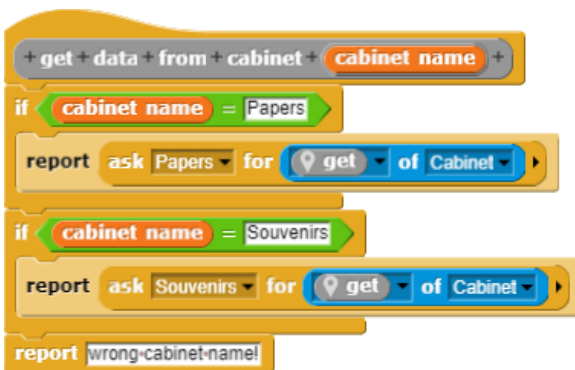

Tasks

1. Implement **access control** for the filing cabinets either at the cabinets or at the IT representative
 - a: by password request.
 - b: with user lists and associated passwords.

2. Process the data for yourself
 - a: by introducing **plausibility checks**.
 - b: with **encryption**.
 - c: with use of **data structures** like lists, rows, stacks, queues, trees, etc.

3. Store the data appropriately in **text files**.

4. Organize a **data center** that stores, backs up and organizes the data of a company (school, family, etc.). Define access rights and methods and implement the procedures.

7.2 Magnets

Contents:

- prototypes and clones
- dynamic creation of clones
- accessing local methods

As a very simple example of how to deal with objects, we select a magnetic field whose orientation near a "north pole" is indicated by "elemental magnets". Those little things should point to the North Pole.

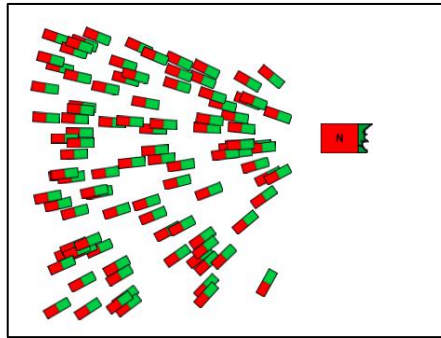

So, we draw the big magnet without any functionality (you can only push it through the area) and a single small one. We provide it with the required properties and clone it as often as necessary.

Pointing to the big one is easy. If an elementary magnet receives the message "come on!", it constantly aligns itself to the north pole.

Cloning is a bit more complicated, because we naturally want to distribute the clones in the image area, like this:

The small magnets are distributed in the left image area - but only if a *clone yourself at <x> <y>* - method is available. We can write it using the new knowledge of method calls of other objects.

We write the method as a block of the elementary magnet. In the method we create a clone and assign it to a local variable. We send the clone to the position indicated by the parameter values, rotate it in any direction and let it appear. Ready.

Dealing with many dynamically generated clones is extremely simple: click on the red stop button at the top-right of the window and everyone will be gone again. And because dynamically generated clones are not displayed in the sprite area, their scripts are really fast. If you move the large magnet, then all elementary magnets are realigned - immediately

Task: Add a "south pole" to the "north pole" and determine the direction of the force on the elementary magnets at their positions. Align the elementary magnets in this field.



7.3 A Learning Robot¹⁸

Contents:

- prototypes and clones
- overriding methods
- accessing local methods

Another example of delegation inheritance is a robot with four touch sensors. If one of these comes into contact with a hindrance, the robot changes its direction, but also has a new dent.

We use a drawing program to draw a picture of a world that is bounded by black walls and in which there are some black obstacles. For reasons we will soon get to know, we spray a diffuse red fog around the objects and along the walls with the spray can. We put *Roby* into this world - as a small circular sprite. Furthermore, we draw an even smaller blue sprite with a predicate *touching the wall?*, so equipped with a touch sensor. We clone this sprite three times and then attach the four sensors to the robot. We call them according to the cardinal points *TouchSensorN*, *TouchSensorE*, ... etc. An aggregation occurs. We equip the robot with two local variables *vx* and *vy*, which describe the velocity components in these directions. If a touch sensor now signals a wall, the corresponding velocity component is changed. We get the following configuration, in which Roby moves between the obstacles - as already mentioned, with many dents.

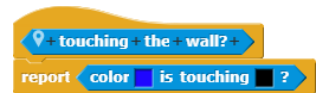

How to make aggregations is shown in the next chapter.

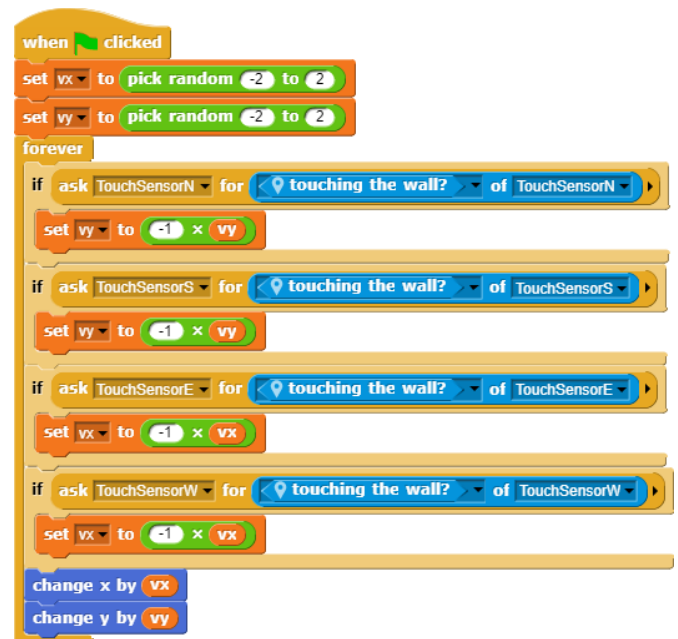
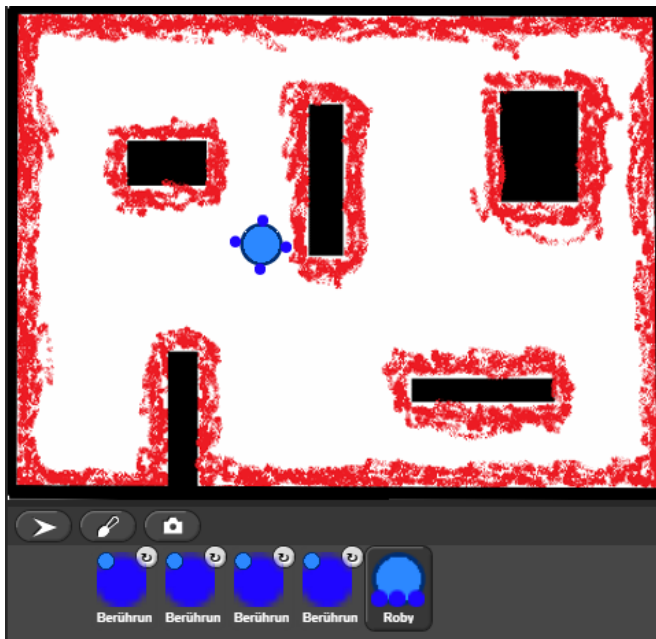

¹⁸ The example has as a template the walking robot of Prof. Florentin Wörgötter, Bernstein Center for Computational Neuroscience Göttingen, described e. g. in http://www.chip.de/news/Schnellster-Roboter-lernt-bergauf-zu-gehen_27892038.html

Now the red spray paint around the obstacles and walls comes into play. This shall identify areas in which an ultrasonic sensor picks up echoes from the objects. We therefore equip the robot with four ultrasonic sensors that react to this red color. We call them *USsensorN*, *USsensorS*, ...

The robot should learn that an ultrasound echo often precedes a collision and that it is therefore better to reverse if this echo is heard. We therefore need a mechanism that detects that there was an echo before a collision. One way to achieve this is a counter in the ultrasonic sensor, which is set to an initial value (here: 100) when it detects red color (i.e. an echo). This counter is continuously counted down to zero - and if necessary, it is increased again before. If this counter has a value greater than zero in case of a collision, the echo has been received shortly before.

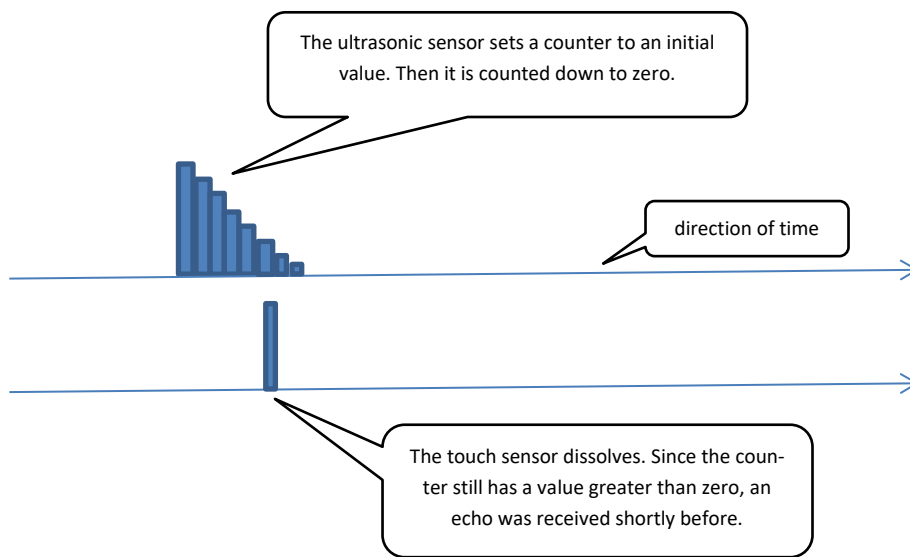

This constellation initiates a learning step that takes place in a *neuron*. It has two inputs, which come from the assigned touch sensor or ultrasonic sensor and each with a *weight*, as well as a *threshold value*. The input from the touch sensor has the weight 1, if a signal of e.g. strength 1 is received from this line, it is multiplied by the weight 1. The result is greater than the threshold value (here: 0.5) and the neuron "fires". The weight of the US sensor initially has a value of 0, which is increased whenever the touch sensor detects that the counter of the assigned ultrasonic sensor has a value greater than zero in the event of a collision. If there are enough such small learning steps, the product of weight and signal of the US sensor also exceeds the threshold value of the neuron and this fires in this case as well.

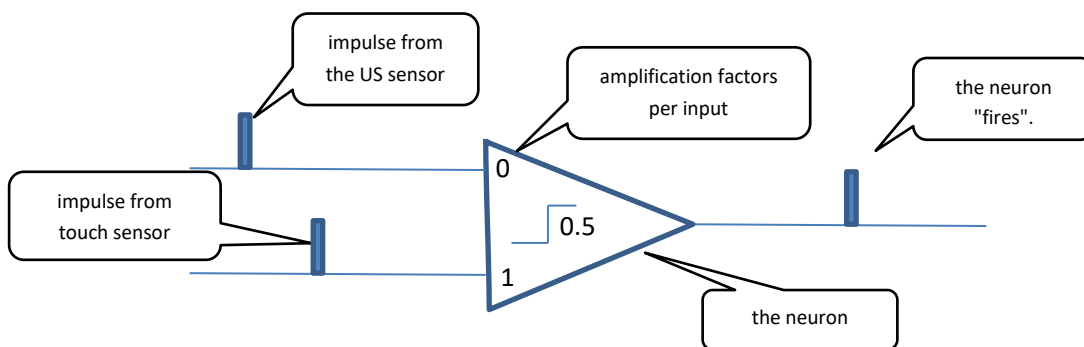

We are now realizing this form of *Pavlovian learning*.

The ultrasonic sensor works exactly as described above. The local attribute *counter* can be accessed directly with the `<attribute> of <object>` block. The actual changes therefore take place in the touch sensors and the four assigned neurons. Since these are clones of the only prototype, it is almost enough to make the additions only in this one. They take over the changes because they inherit the methods of the prototype. However, we still must specify which element of the four groups the sprite should react to.

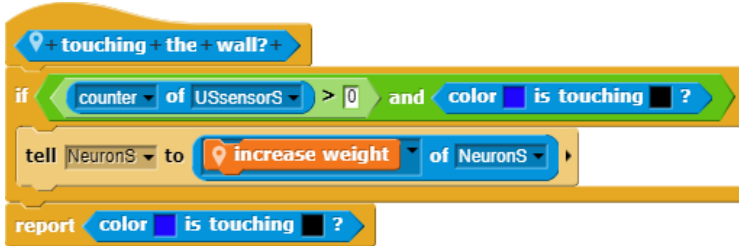

When touching a wall, it is still necessary to determine whether the associated ultrasound sensor has triggered "shortly before".

In the clones, we overwrite the inherited "pale" method by adjusting the associated sensor. This also makes the pallor disappear. Previously, we cloned the ultrasound sensor and neuron three times and added the four new purple ultrasound sensors and the yellow neurons to Roby. He looks like this now:



The neuron still need a predicate *is firing?* which works as described above.



Finally, we change Roby's behavior: he changes his direction when the corresponding neuron fires.

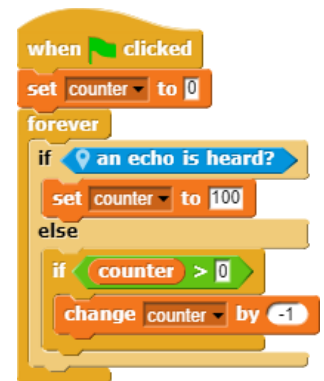

inside the neuron

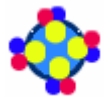

Roby with sensors and neurons

Roby now looks for his way, first between the obstacles, then along the "echo range".

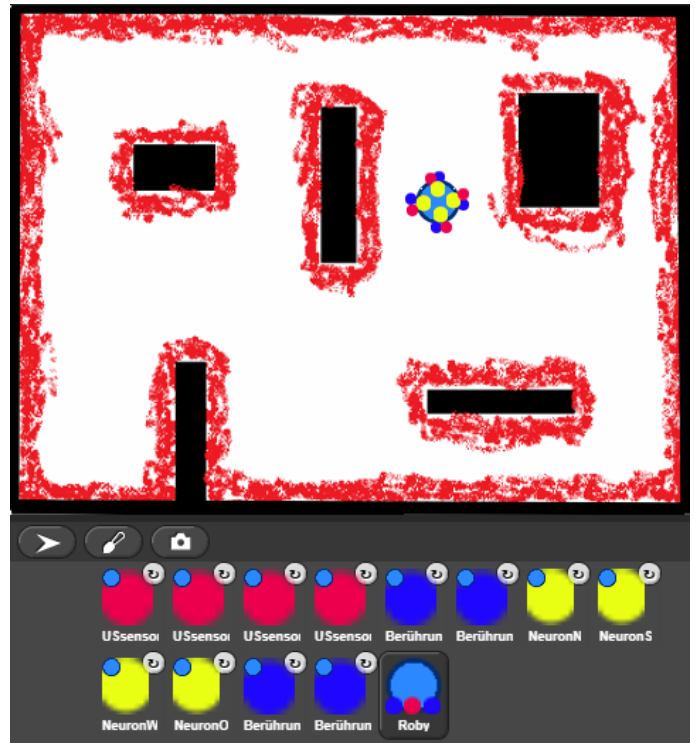

Tasks

1. Give the program an **interface** that makes it easy to change the main factors: its speeds, weights and thresholds.
2. Introduce additional **sensor types** and other events in addition to the collisions.
 - a: Let Roby find correlations between sensor values and events in different "worlds". Roby thus adapts to its surroundings.
 - b: Discuss other ways Roby adapts to a changing environment.
3. Discuss the need for "**forgetting**" and possibilities to realize this process.
4. Replace Roby with a mouse with a cheese sensor. Put it in a **labyrinth**. Let it look for the cheese there.

7.4 A Digital Simulator

Contents:

- aggregations
- static and dynamic creation of clones
- use of the launch block

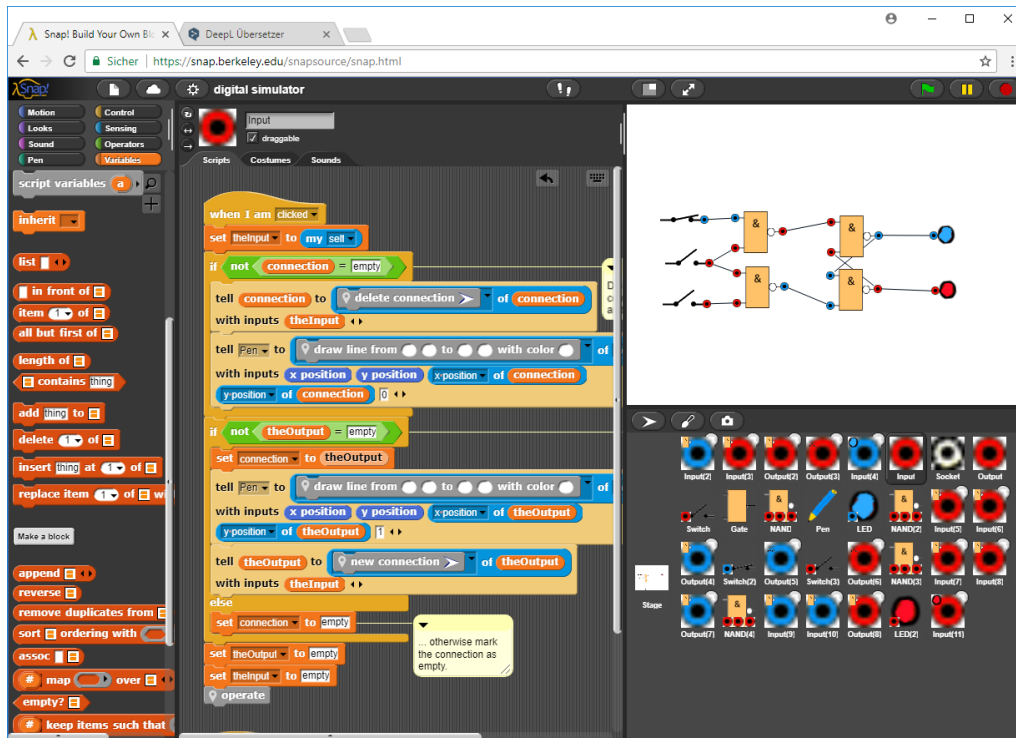

A digital simulator is a program that can be used to simulate digital circuits. It consists of switches, LEDs and gates, in this case only NANDs (Not AND) from which all other circuits can be constructed. Different types of sockets are located on the components, which are used to transmit signals.

We can display the correlations clearly in a (simplified) UML diagram:

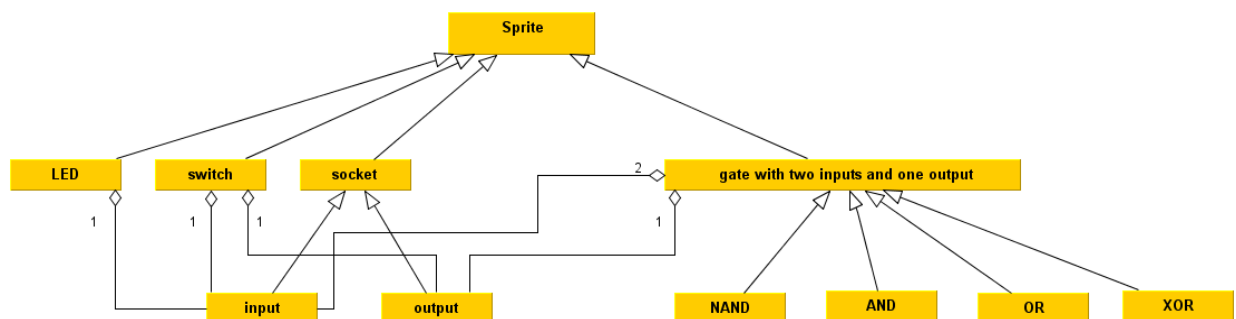

In this case, the inheritance takes place via delegation.

7.4.1 Sockets and Connections

As the "mother of all sockets (*jacks*)" we draw a *neutral socket* which serves as a prototype for *input* and *output* sockets. All sockets have a value that can be 0 or 1, but inputs get their value from the cable or, if they are not connected, we set them to the value 1 for technical reasons. They represent the result of a logical circuit. All jacks inherit from the neutral jack the method *show yourself*, which represents their value, as well as a local variable named *value*.

Using the context menu (*clone*), we create two clones of the neutral socket, which serve as prototypes for inputs and outputs.



Sockets should be connected by clicking on an output first and then an input. If only the input is clicked, then its connection to an output is deleted - if it exists. Connections are presented only as lines on stage. If the switching elements are moved afterwards, the lines remain "free in space".¹⁹

Inputs can be connected to one output at the most. For this, they get an additional variable *connection*. Outputs can distribute their values to several inputs, therefore they receive a list variable *connections* for the connected inputs. If an output is clicked, the global variable *theOutput* receives this output as its value. If an input is clicked, it updates the connections.

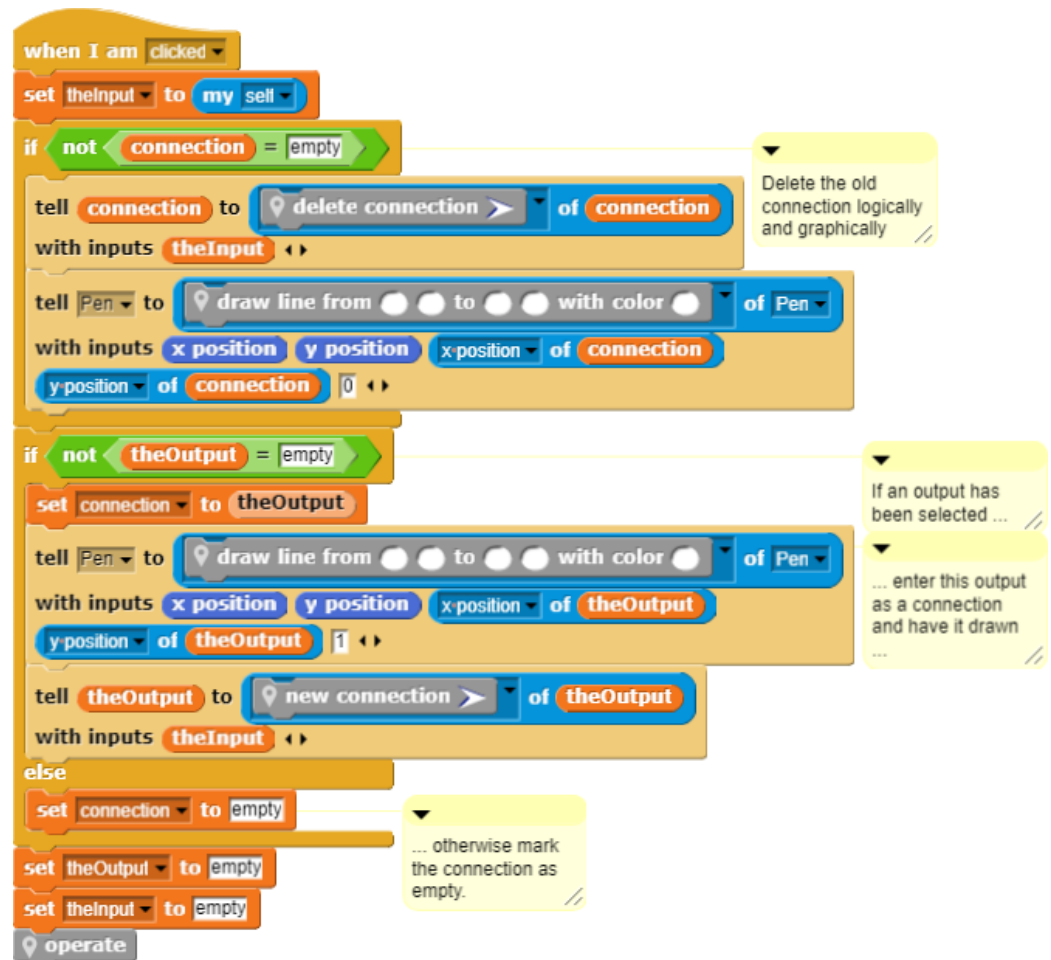

¹⁹ The representation and especially the arrangement of lines is an independent problem.

For outputs it's a bit easier: they provide the options for entering and deleting connections - and wait for what comes.

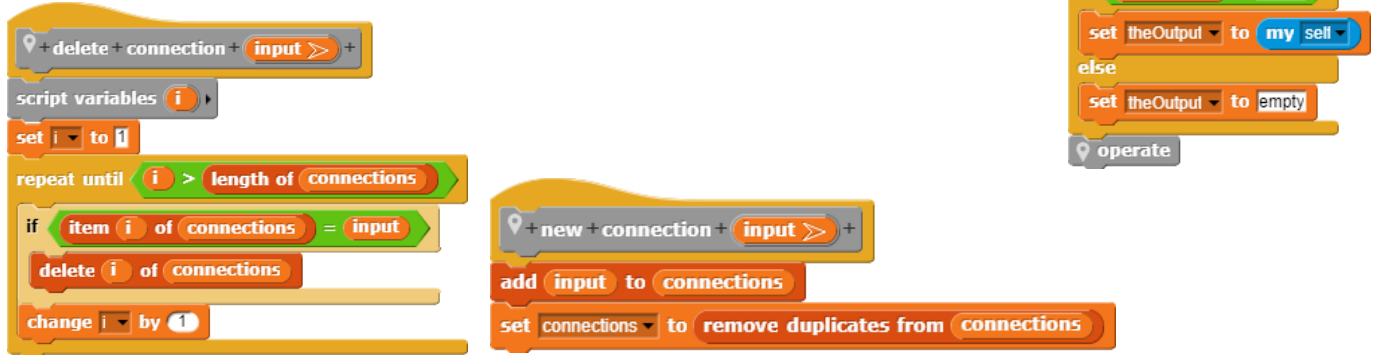

7.4.2 Switches

Switches are used to change output values. We create two costumes representing the open or closed state. At the right end, an output socket is connected, which either has the value 1 (status "open") or 0 (status "closed"). The socket is obtained by cloning the output socket. Afterwards we push the sprite to the correct position at the switch. Now it must be anchored there. To do this, we move the sprite symbol from the sprite area over the switch in the output window. Its outline lights up when it notices that it is meant. This means that the socket is attached to the switch: it is the *anchor* of the resulting aggregation.

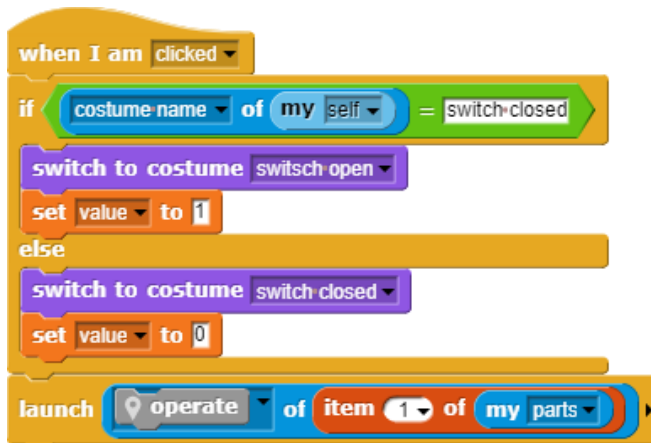
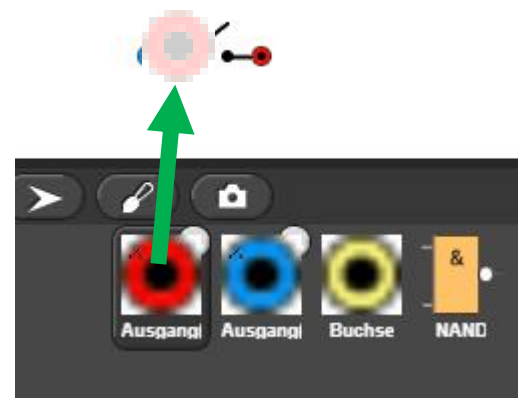

Since we want to use the components of our digital simulator via mouse, it is advisable that the switch reacts to mouse clicks. This is easy to achieve: he changes the costume with every click. To do this, he needs to know what he looks like: with *<costume-name> of <my self>* he gets the current costume.

Generate an aggregation of sprites: the socket becomes element of the switch's parts list and are displayed on the sprite symbol of the switch.



With *detach from ...* from the context menu of the socket, they can be removed from the switch.

We still need a mechanism to control the reactions of the *parts*, this time of the output socket. Since it should be transferable, the procedure must be generally applicable. We therefore equip each component with an *operate* method and a variable *value*. If the state of the switch changes, the value of the switch changes. Finally, it calls the *operate* method of the output - this is the first element of the *parts* list. We use the *launch* block to keep the program running.

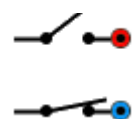

7.4.3 Gates

To create gates, we first introduce a prototype *Gate* with two inputs and one output. It also contains a variable *switching time*. We attach the necessary sockets as learned with the switches. Other gates such as AND, OR, XOR or NAND can be derived from this gate. For the NAND we create a clone of the *Gate* named NAND and provide it with an adapted costume.

The prototypes derived from the *Gate* inherit the *operate* method of the gate and the instance variable *value*. Both are of course superfluous, because the gate has no proper function at all. We therefore leave the method blank and overwrite it in the derived prototypes. (If we forgot something, we can create variables and methods in the prototype afterwards. These are immediately passed on to the clones. Inherited attributes and methods appear slightly brighter in clones than their own. If they are overwritten, they get the normal color.)

NAND's *operate* method is easy to write. The *my <parts>* block shows us the inputs and outputs of the NAND. We can read out their values or set them like at the switch. We use the *launch* block instead of the *run* block again.

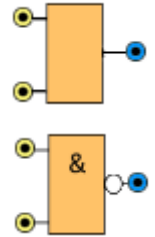
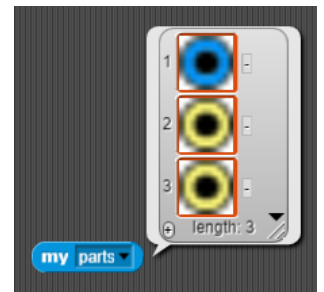
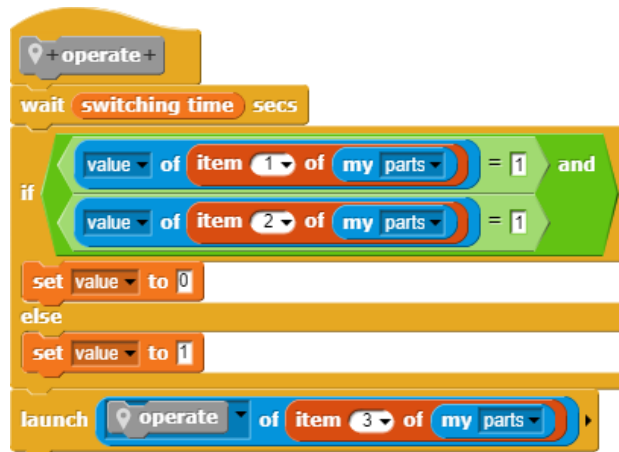

7.4.4 The Pen

The pen provides only one simple method for drawing straight lines in different colors on stage. He does not have any other tasks.



7.4.5 LEDs

As a very simple example for adding new components to the system, we introduce the prototype of an LED (*light emitting diode*). This receives two costumes for the values 0 and 1 as well as one input. Because the input is familiar with the system, the LED can fully rely on them and limit itself to what LEDs do - light up. Nothing more can be done.

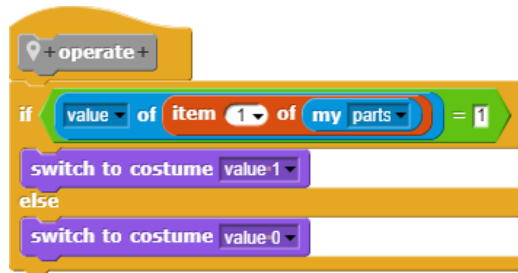

7.4.6 The Interaction of the Components

The activity is to pass through our network in a wave-like manner in a *feed-forward* process: Each part notifies the connected parts and calls their *operate* method when something has changed. For example, if an output socket is located on a switch, the output's *operate* method is called when it is clicked and therefore changes its value. This in turn activates all connected inputs. Each of these inputs calls the working method of the gate on which it is located - but only if its value has changed. If not, the wave is stopped here. So far, the gate can only be a NAND. It waits its *switching time*, reads the values of its inputs and activates the output - etc.

We take the *operate* methods of input and output as examples.

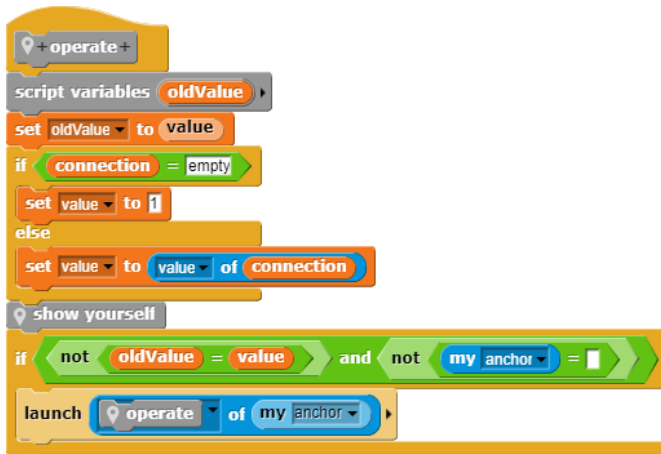

7.4.7 Tasks

1. Create prototypes for the following **gates** according to the model of the NANDs:
 - a: an AND
 - b: an OR
 - c: a XOR
 - d: an Not-OR (NOR)
2. Create a prototype for a **NOT** gate. It has only one input and one output.
3. Create a prototype for a **clock**. The clock frequency should be adjustable.
4. Create a prototype for **RS-FlipFlops** (RS-FF). Inform yourself beforehand about how they work.
5. Create a prototype for **JK-MS-FlipFlops** (JK-FF). Inform yourself beforehand about how they work.
6. Our gates react only after a switching time which can be different. Why actually?

8 Graphics

Contents:

- simple turtle graphics
- recursive curves
- acceleration of output
- implementation of JavaScript functions

8.1 Line Graphics

In *Snap!* each sprite has a (virtual) pencil to draw on stage. The blocks for this can be found in the *Pen* and *Motion* palettes. In the first one the pen is controlled, i.e. raised or lowered, pen color and width are adjusted, ... The second one contains the commands for moving the sprite. In this movement, the pen leaves traces, which form the generated line graphics - and which can be further processed as *pen trails*.

If we choose the already known "pen" as costume, the following script creates a simple circle.

```

go to x: 0 y: 0
clear
pen up
pen down
repeat 360
  move 1 steps
  turn 1 degrees
  
```

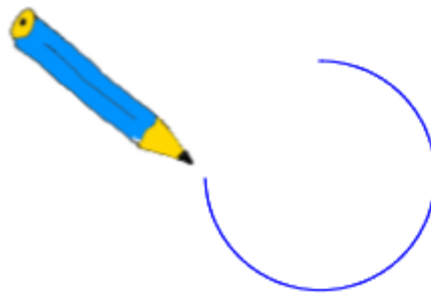

```

warp
go to x: 0 y: 0
clear
pen up
pen down
repeat 360
  move 1 steps
  turn 1 degrees
  
```

The example demonstrates the effect of the *warp* block. While without it the pencil draws the circle quite comfortably, the finished circle appears almost immediately with *warp* block. The reason is that in the first case, the state of the system is shown again after each block execution, whereas in the second case this is only done at longer intervals. The difference is "dramatic". Similar acceleration can be achieved using the *Turbo mode* option in the *Settings* menu.

With the help of turtle graphics, some of the familiar recursive curves can be drawn very elegantly. We start with the *snowflake* (or *Koch*) curve. It is created by repeatedly putting a triangle in the middle of a side until the side is too short for this process. In this case, the side is drawn as a straight line. A snowflake is created by assembling an equilateral "triangle" of three such sides.

Pen palette

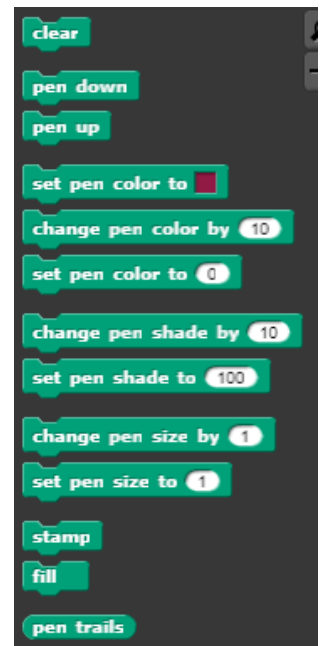

Motion palette

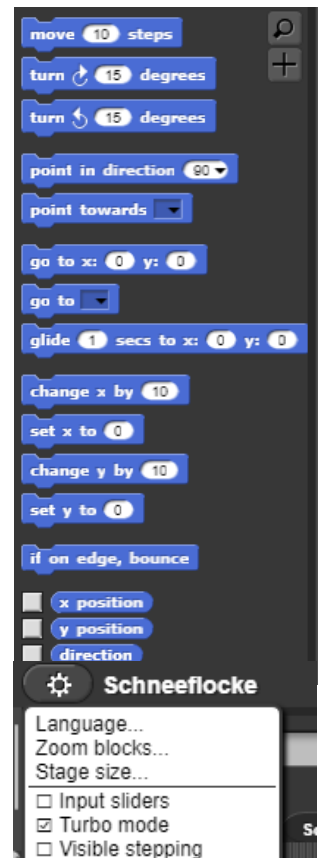

draw snowflake side of length n

	n < 2
true	false
draw line of length n	draw snowflake side of length n/3
	turn by -60°
	draw snowflake side of length n/3
	turn by 120°
	draw snowflake side of length n/3
	turn by -60°
	draw snowflake side of length n/3

The process can be translated directly to *Snap!*:

```

+ draw + snowflake + n # = 100 +
warp
clear
hide
pen down
repeat 3
  draw snowflake side n
  turn 120 degrees
show
pen up
    
```

```

+ draw + snowflake + side + n # = 100 +
if n < 2
  move n steps
else
  draw snowflake side n / 3
  turn 60 degrees
  draw snowflake side n / 3
  turn 120 degrees
  draw snowflake side n / 3
  turn 60 degrees
  draw snowflake side n / 3
    
```

the snowflake curve

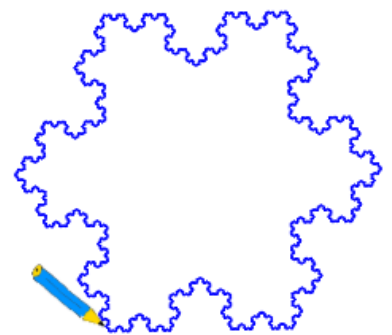

To construct the *Hilbert curve* we use a version according to László Böszörményi²⁰. It is one of the area-filling curves, which as a generator has a kind of box. The corners of the box are located in the centers of the four quadrants of a square. In the next step, this box is reduced by half and four versions of it are rearranged in the quadrants in mirrored or rotated versions. Finally, the smaller boxes are connected to each other as shown on the next page.

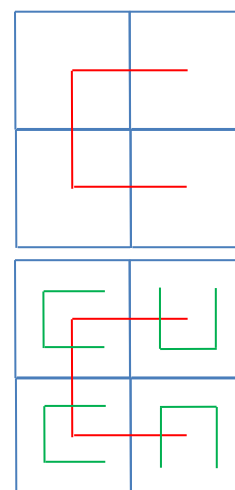

the generator

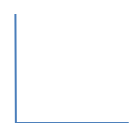

its position in the square

In the Böszörményi version, the boxes are marked with A to D depending on orientation and direction of rotation.

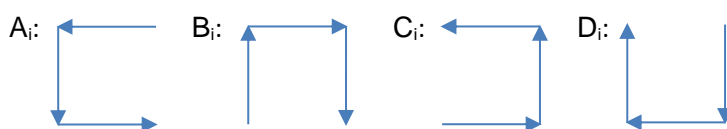

²⁰ <http://bscwpub-itec.uni-klu.ac.at/pub/bscw.cgi/d11952/10.%20Rekursive%20Algorithmen.pdf>

The Hilbert curve is composed of these elements by starting with *A* and "twisting" the other elements. Parameter *i* specifies the recursion depth and thus the size of the elements. It is "counted down" to zero.

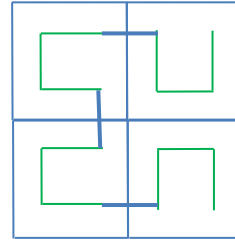

the scaled-down copies and their connections

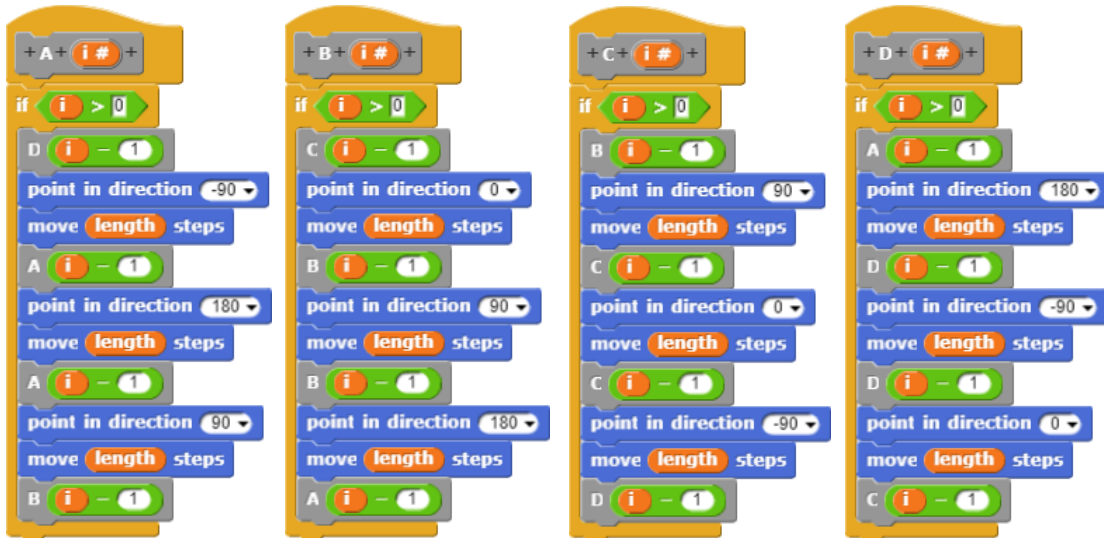

The call takes place as described after the sprite is sent to the starting point right-up. The final length of the sections to be drawn is determined from the recursion depth - and then it is drawn. Here too, the effect of the warp block is drastic.

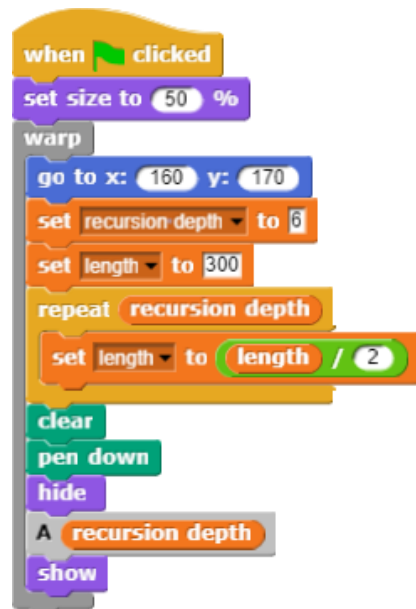
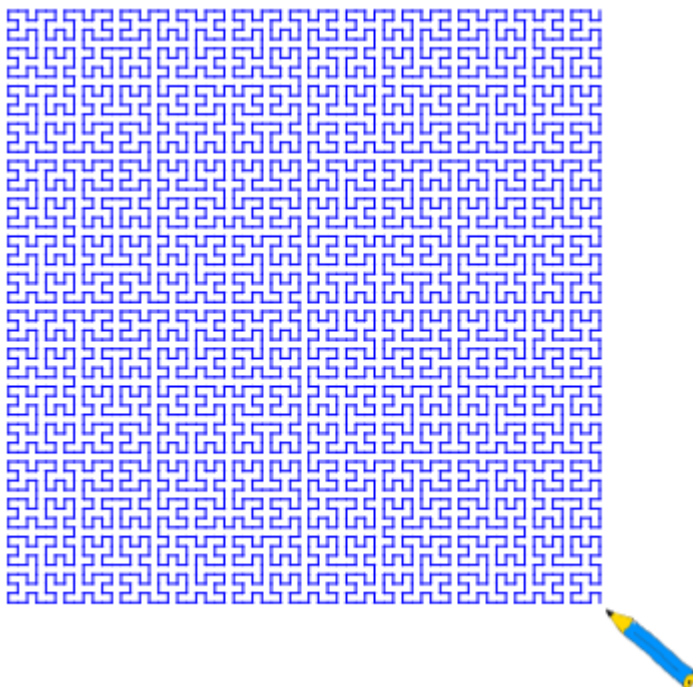

8.2 Pixel Graphics and RGB Model

Contents:

- single pixel access
- RGB colors
- implement your own pixel graphics library

Turtles draw on *stage*, but pixel graphics are only possible on costumes of sprites. This is not a big limitation, because with help of the *pen trails* block the current state of the stage can be transformed into a costume, which can be drawn back on stage if necessary. Drawing on costumes has the advantage that *JavaScript* commands related to this area can be used without knowledge and consideration of the rest of the *Snap!* program code. If required, you have a small playground where you can write programs in the text-based language JavaScript within the graphical environment of *Snap!*. This also makes sense if, for example, blocks are missing or if speed is important. We want to implement pixel graphics in two ways: first using the *pixels* library provided with *Snap!* and then directly using JavaScript blocks.

8.2.1 Pixel Graphics with the Pixels Library

We import the *pixels* library (File → Libraries → pixels) and get some new blocks. The palettes result from the block colors. These blocks allow us to access the pixels of a costume.

First of all, we need a costume: beautiful white and big. We set the stage to 800x600 pixels and get a copy of the empty stage. So, we know the dimensions of the costume - just 800 x 600, and after creating the corresponding variables we have found the beginning of our script. In the copy of the stage costume we find the individual pixels in form of a long list, which contains both the RGB values of the costume and the transparency.

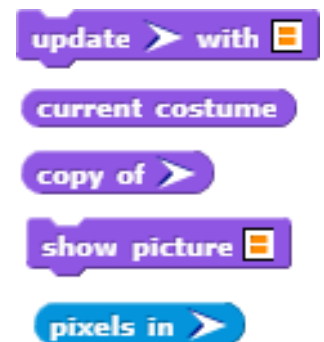
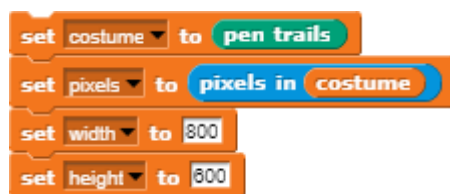

Another way to get a corresponding costume would be to create it in a graphics program as a white rectangle and import it. As a third possibility we will write a small JavaScript method.

Now we can manipulate the values of the list *pixels*. As an example, we set the green and blue values to zero. Since 480000 values have to be changed, the use of the *warp* block can do no harm.

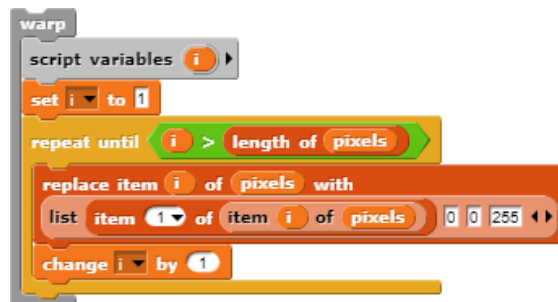

pixels				
480000	A	B	C	D
1	250	255	255	255
2	250	255	255	255
3	250	255	255	255
4	250	255	255	255
5	250	255	255	255
6	250	255	255	255
7	250	255	255	255
8	250	255	255	255
9	250	255	255	255
10	250	255	255	255
11	250	255	255	255
12	250	255	255	255
13	250	255	255	255
14	250	255	255	255
15	250	255	255	255
16	250	255	255	255
17	250	255	255	255
18	250	255	255	255
19	250	255	255	255
20	250	255	255	255
21	250	255	255	255
22	250	255	255	255
23	250	255	255	255
24	250	255	255	255
25	250	255	255	255
26	250	255	255	255
27	250	255	255	255
28	250	255	255	255
29	250	255	255	255

Up to now, the changes have only taken place in list *pixels*. They still must be "added back" in order to get a visible change. If you want the change to influence the stage, you can copy it with the **stamp** - block.

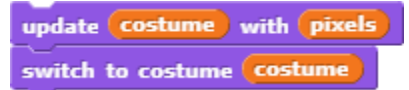

The pixel list is well suited for counting colors in a costume, for example. It's not so easy to access individual pixels given by coordinates. We therefore write two blocks to set or read the RGB values at a (x|y) position.



The *setRGB* block can be used to draw very nice color gradients, e. g. the *RGB cube* with the front, top and right side.

The RGB colour cube is composed of three sides.

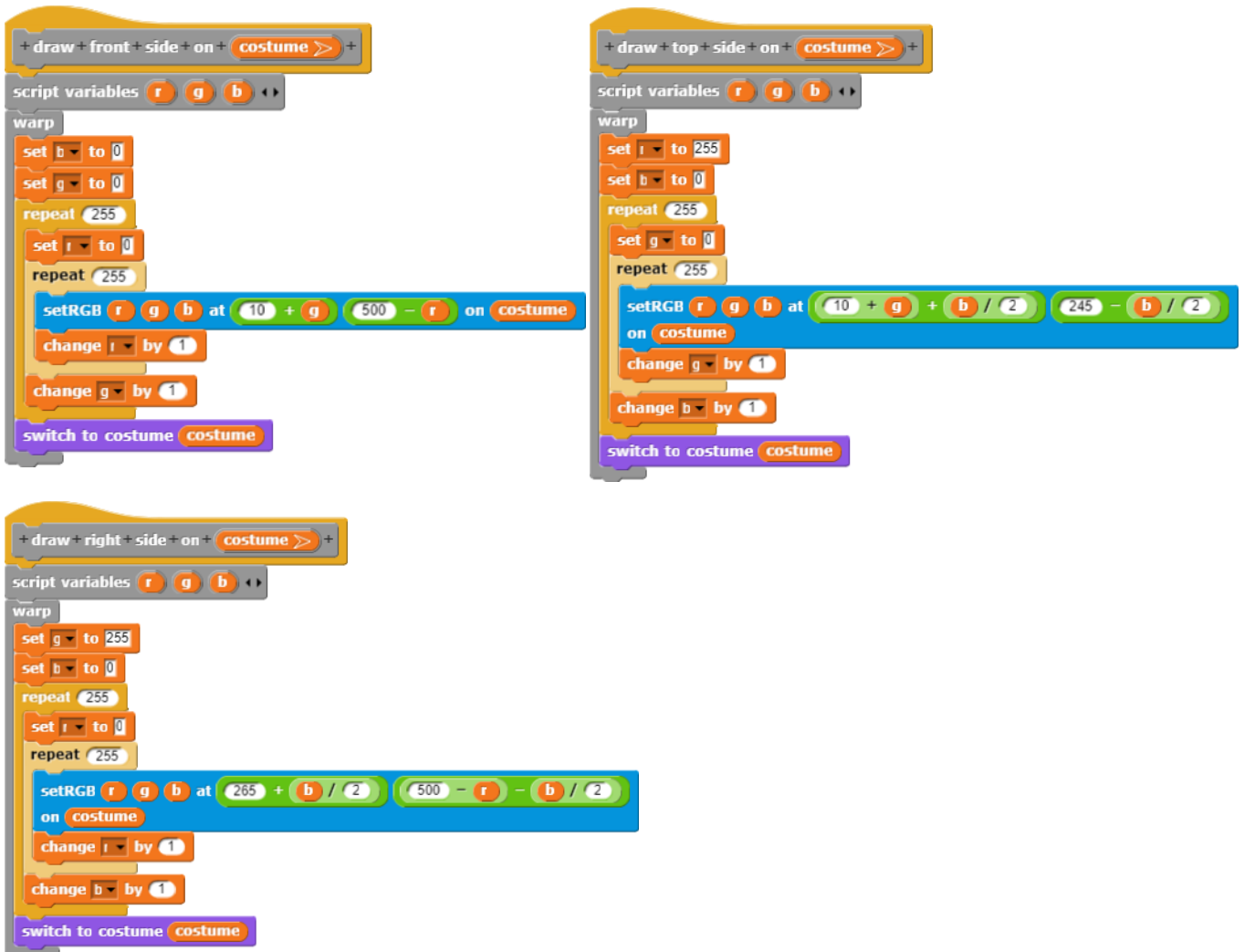

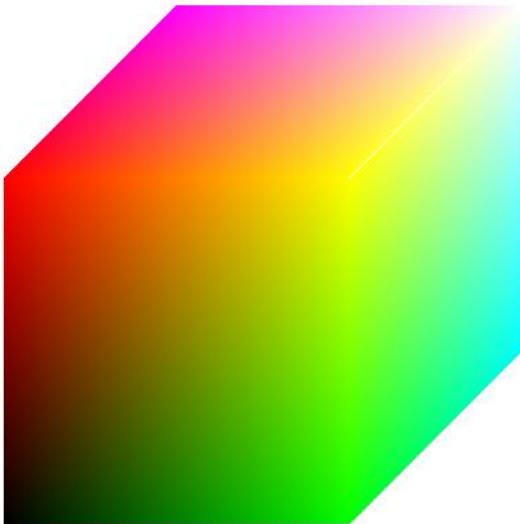

```

set costume to produce costume
pen up
go to x: 0 y: 0
draw front side on costume
draw top side on costume
draw right side on costume

```

8.2.2 Pixel Graphics with an own Library

We want to create blocks using the *JavaScript function* block, which we use to exploit some of the graphical features of JavaScript.²¹ First, we create the capability to "inflate" an existing costume to a desired size. Since all old content will be lost in this change anyway, we fill the resulting rectangle with white color.

```

+set+ size+ of+ costume >> +to+ x # + y # +
JavaScript function ( costume x y ) {
costume.contents.width = x;
costume.contents.height = y;
var ctx = costume.contents.getContext('2d');
run ctx.beginPath();
ctx.fillStyle = new Color(255,255,255).toString();
ctx.fillRect(0,0,x,y);
ctx.closePath();
ctx.stroke();
}
with inputs costume x y

```

Sometimes we need to know the dimensions of a costume, but we don't necessarily know them. So we create the capability for this.

```

+get+ width+ of+ costume >> +
JavaScript function ( costume ) {
call var ctx = costume.contents.getContext('2d');
return costume.contents.width;
}
with inputs costume

```

```

+get+ height+ of+ costume >> +
JavaScript function ( costume ) {
call var ctx = costume.contents.getContext('2d');
return costume.contents.height;
}
with inputs costume

```

²¹ The pixels library provides good templates for this.

In this costume we we again want to be able to access single pixels .

```

+ getRGB from costume >> at x # = 1 + y # = 1 +
report
JavaScript function ( costume x y ) {
call
var ctx = costume.contents.getContext('2d');
data = ctx.getImageData(x,y,1,1);
return new List(new Array(data.data[0], data.data[1], data.data[2]));
}
with inputs costume x y
    
```

```

+ setRGB r # = 255 + g # = 180 + b # = 100 at x # = 1 +
y # = 1 on costume >> +
JavaScript function ( r g b x y costume ) {
run
var ctx = costume.contents.getContext('2d');
ctx.beginPath();
ctx.lineWidth = 1;
ctx.strokeStyle = new Color(r,g,b).toString();
ctx.moveTo(x,y);
ctx.lineTo(x+1,y);
ctx.closePath();
ctx.stroke();
}
with inputs r g b x y costume
    
```

And while we're at it, we also draw lines, filled and empty rectangles and corresponding circles.

```

+ draw line from xa # = 1 + ya # = 1 + to xe # = 100 +
ye # = 100 + color r # = 255 + g # = 128 + b # = 100 on +
costume >> + width width # = 1 +
JavaScript function ( xa ya xe ye r g b costume width ) {
run
var ctx = costume.contents.getContext('2d');
ctx.beginPath();
ctx.lineWidth = width;
ctx.strokeStyle = new Color(r,g,b).toString();
ctx.moveTo(xa,ya);
ctx.lineTo(xe,ye);
ctx.closePath();
ctx.stroke();
}
with inputs xa ya xe ye r g b costume width
    
```

```

+ draw rect between xa # = 1 + ya # = 1 + and xe # = 100 +
ye # = 100 + color r # = 255 + g # = 128 + b # = 100 on +
costume >> + width width # = 1 +
JavaScript function ( xa ya xe ye r g b costume width ) {
run
var ctx = costume.contents.getContext('2d');
ctx.beginPath();
ctx.lineWidth = width;
ctx.strokeStyle = new Color(r,g,b).toString();
ctx.strokeRect(xa,ya,xe-xa,ye-ya);
ctx.closePath();
ctx.stroke();
}
with inputs xa ya xe ye r g b costume width
    
```

```

+ fill rect between xa # = 1 + ya # = 1 + and xe # = 100 +
ye # = 100 + color r # = 255 + g # = 128 + b # = 100 on +
costume >> +
JavaScript function ( xa ya xe ye r g b costume ) {
run
var ctx = costume.contents.getContext('2d');
ctx.beginPath();
ctx.fillStyle = new Color(r,g,b).toString();
ctx.fillRect(xa,ya,xe-xa,ye-ya);
ctx.closePath();
ctx.stroke();
}
with inputs xa ya xe ye r g b costume
    
```

```

+ draw circle x # = 100 + y # = 100 + radius radius # = 50 on +
costume >> + color r # = 128 + g # = 100 + b # = 100 + width +
width = 1 +
JavaScript function ( x y radius costume r g b width ) {
run
var ctx = costume.contents.getContext('2d');
ctx.beginPath();
ctx.lineWidth = width;
ctx.strokeStyle = new Color(r,g,b).toString();
ctx.arc(x,y,radius,0,6.283185307179586476925286766559);
ctx.closePath();
ctx.stroke();
}
with inputs x y radius costume r g b width
    
```

```

+ fill circle x # = 100 + y # = 100 + radius radius # = 50 on +
costume >> + color r # = 255 + g # = 0 + b # = 0 +
JavaScript function ( x y radius costume r g b ) {
run
var ctx = costume.contents.getContext('2d');
ctx.beginPath();
ctx.fillStyle = new Color(r,g,b).toString();
ctx.arc(x,y,radius,0,6.283185307179586476925286766559);
ctx.fill();
ctx.closePath();
ctx.stroke();
}
with inputs x y radius costume r g b
    
```

These blocks are stored in a separate library (*File → Export blocks...*), where we select which blocks are to be included. With this we can create our color cube again by replacing the *setRGB* method with the new version.

```

set costume to copy of current costume
set size of costume to 800 600
pen up
go to x: -100 y: 200
draw front side on costume
draw top side on costume
draw right side on costume
    
```

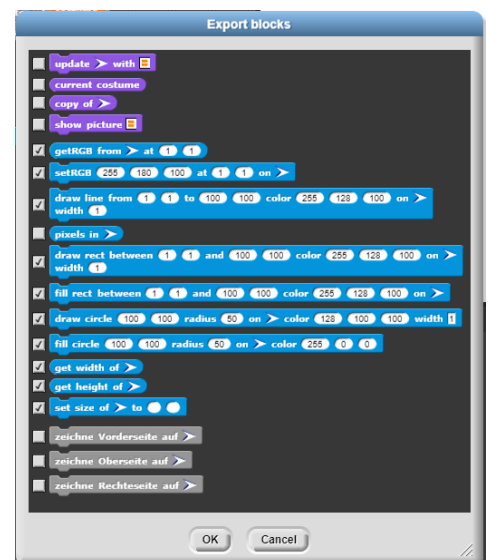

8.3 The Light of the Old Stars

In normal galaxies, the young stars are usually "born" in the arms of the galaxies, while the old stars throng in the centers of the galaxies. Since young stars tend to shine in the blue range of the spectrum and old stars tend to shine in the red range, this can be checked well. We choose several galaxy pictures as costumes. We copy the current costume into the variable *costume*, create a pixel list called *pixels* and "map" a function *red value > n in...*, which displays pixels with a red value larger than the parameter *n* as pure red values, the other black. All these elements are now well known from other examples.

```
switch to costume NGC-5457
set size to 150 %
set costume to copy of current costume
set pixels to pixels in costume
set pixels to map red channel > 150 in over pixels
update costume with pixels
switch to costume costume
```

For the galaxy *NGC 5457* we get the following result:

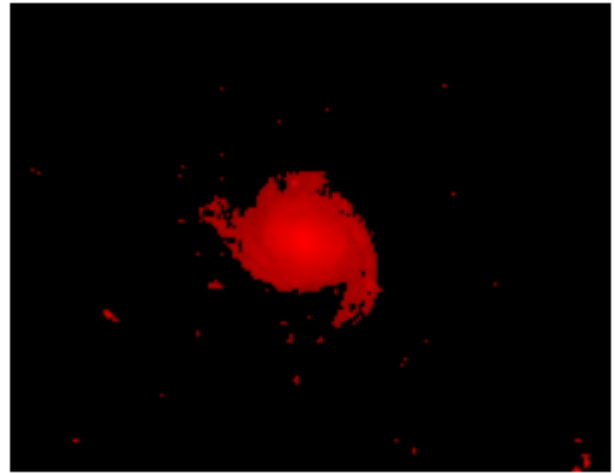

With *M101* it works also!

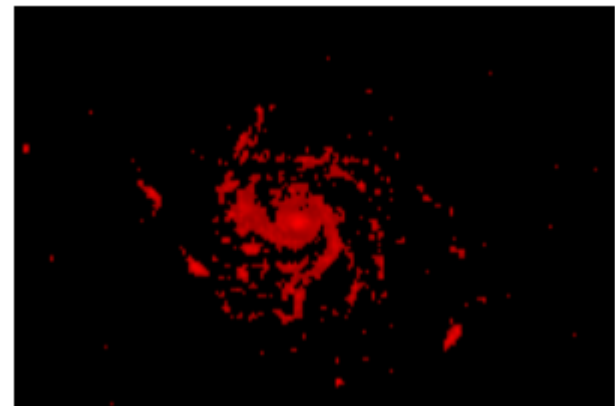

8.4 A simple RGB Color Mixer

For three color values *red*, *green* and *blue*, we want to represent the pure color channels as well as the mixed color with correspondingly filled rectangles. To do this, we import the library with the JavaScript RGB methods and generate three variables for the color channels, which we display on the screen in slider format. As maximum values we select 255.

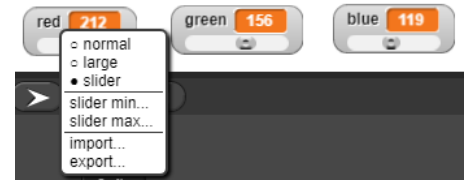

We create a costume from the *pen trails* on *stage* and write a script for the stage, which reacts on clicking (more exactly: releasing the mouse button on stage). If we now change one of the sliders for the variables and then let go of the mouse button first on stage, e. g. below the variables, the script will be executed.²² It works pretty well.

The coordinate system of a costume is oriented differently from that of the stage: it has its origin in the top-left corner and the y-axis is directed downwards. So, we have to select the position of the rectangles to be drawn in this coordinate system.



First, we draw a white rectangle that covers the entire stage. This deletes any old representations. Then we draw three rectangles above the variables in its colors and, to top it all off, a rectangle in the mixed color above all. Afterwards, as is customary now, the costume is switched.

²² The procedure corresponds approximately to the reaction to the OnChange event of other programming languages.

8.5 Drip Painting

One of the methods of bringing randomness into modern painting is to spray paint blotches on the canvas with a brush. The impinging drops of paint are further split upon impact, resulting in a random pattern. We want to simulate the *drip painting* process - and that is not so easy.

We try to do this with a simple but computationally very intensive approach: n random circles with slightly different colors are created within a rectangle, which become more transparent towards the edges of the rectangle. This is the place where the ink thickness decreases. Since n is in the order of hundreds and we want to distribute a few thousand drops per image, we transfer the drop drawing to a JavaScript function that can do this very quickly.

As parameters we pass the coordinates of the upper-left dot-corner in the costume, the width and height of the rectangle describing the drop, the three RGB color values and the number of "partial drops". The function determines (as is now known) the 2D graphic context and calculates a radius for the core area of the drop. Afterwards, the coordinates of the image center are determined, and n drops are drawn whose positions, radii, colors and transparency are selected randomly.

A strongly enlarged "drop" will look like this:

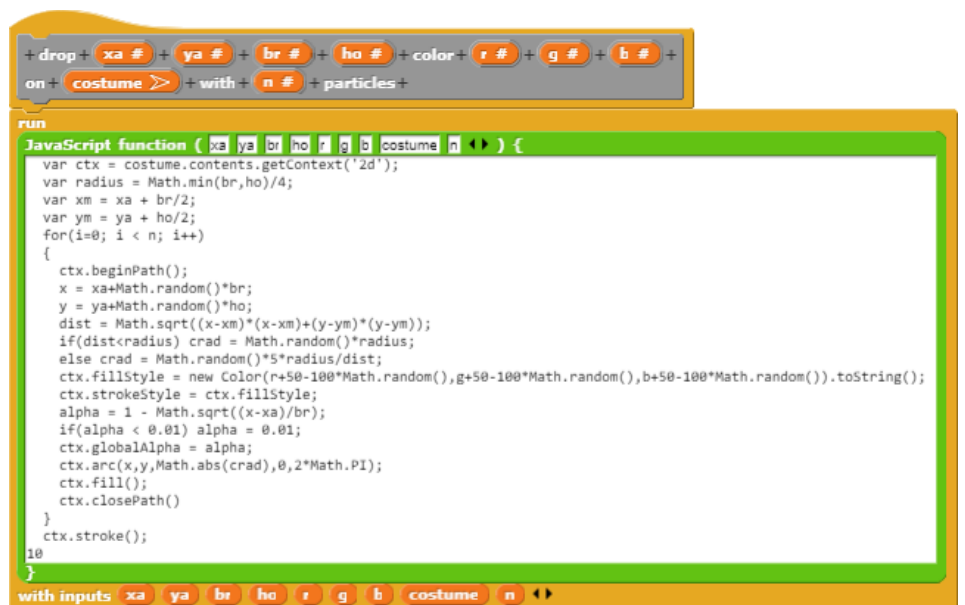

```

run
JavaScript function ( xa ya br ho r g b costume n ) {
var ctx = costume.contents.getContext('2d');
var radius = Math.min(br,ho)/4;
var xm = xa + br/2;
var ym = ya + ho/2;
for(i=0; i < n; i++)
{
  ctx.beginPath();
  x = xa+Math.random()*br;
  y = ya+Math.random()*ho;
  dist = Math.sqrt((x-xm)*(x-xm)+(y-ym)*(y-ym));
  if(dist<radius) crad = Math.random()*radius;
  else crad = Math.random()*5*radius/dist;
  ctx.fillStyle = new Color(r+50-100*Math.random(),g+50-100*Math.random(),b+50-100*Math.random()).toString();
  ctx.strokeStyle = ctx.fillStyle;
  alpha = 1 - Math.sqrt((x-xa)/br);
  if(alpha < 0.01) alpha = 0.01;
  ctx.globalAlpha = alpha;
  ctx.arc(x,y,Math.abs(crad),0,2*Math.PI);
  ctx.fill();
  ctx.closePath()
}
ctx.stroke();
}
with inputs xa ya br ho r g b costume n

```



We now distribute several thousand of these drops on the canvas - and receive an optimistic, abstract picture of *spring-time*.

```

when clicked
  set costume to pen trails
  go to x: 0 y: 0
  switch to costume costume
  repeat 10000
    drop pick random 1 to get width of costume - 70
      pick random 1 to get height of costume - 70
      pick random 10 to 100 pick random 10 to 100 color
      pick random 0 to 255 pick random 0 to 255
      pick random 0 to 255 on costume with pick random 20 to 300
      particles
    switch to costume costume
  
```

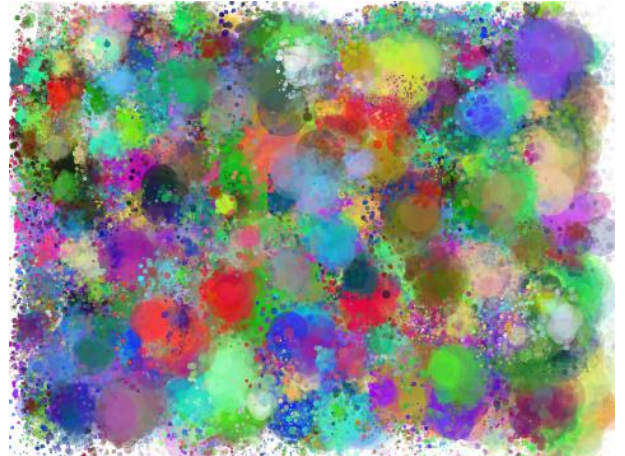

But of course, we can also make the color distribution dependent on the position - and get *some red and a lot of blue*.



With some green to go with it: *Untitled 37*.

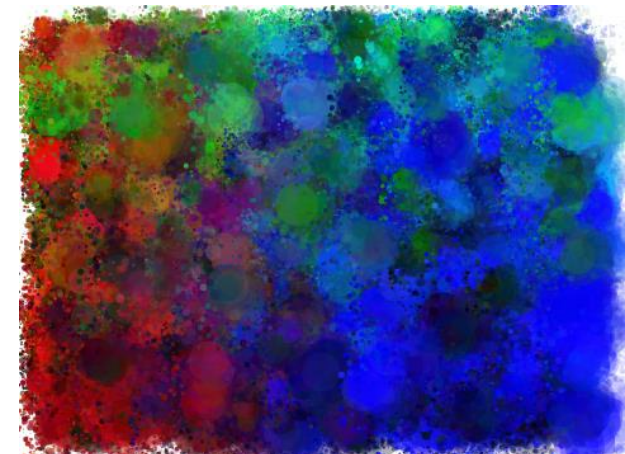

And of course, you can also become braver: *balancing act* 😊

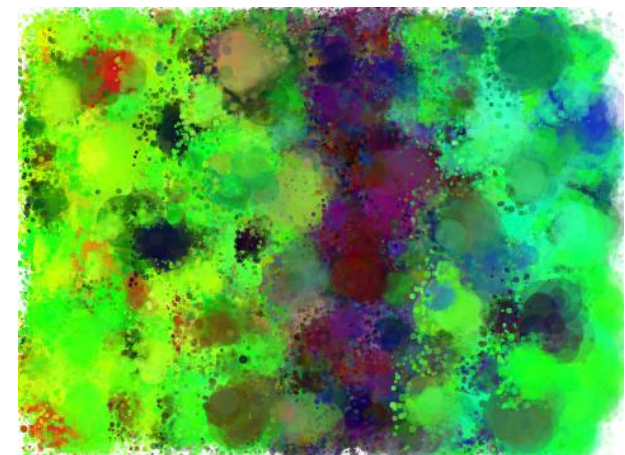

8.6 Edge Detection

In order to recognize objects in an image, it is often helpful to emphasize the boundaries of these objects - the *edges*. A possible method for doing this consists of the steps 1) conversion to a *grayscale image*, 2) conversion to a *black-and-white image* using a threshold value and 3) *edge detection* in this black-and-white image. The first two steps can be carried out relatively quickly with *Snap!* using the *Map* function, and the third one requires a lot of computing power, so there are plenty of opportunities for coffee breaks. Or, after we have developed the procedure in *Snap!*, we transfer this task to a *JavaScript* function. Edge detection is a preliminary stage for object recognition. The recognition of the license plate of a motor vehicle on a video image may be an example.

We look for a picture with visible edges and load it as a costume of our sprite. Afterwards we save costume and pixel list (as already done before) in the variables *costume* and *pixels*. The width and height of the image is determined with the functions *get width* and *get height*.

This image is to be converted into a grayscale image. We can achieve this step-by-step by editing the individual pixels - a typical task for the *map... over* function. This requires a function to be applied to the individual list elements. We call it *color of... → gray*. It calculates the mean value *gray* of the three RGB values and assigns them to the three color channels. It leaves the transparency value unchanged.

```

warp
  set in gray to map color of [ ] --> gray over pixels
  update costume with in gray
  switch to costume costume

+ color of + pxl : + --> + gray +
script variables gray
set gray to
  round
  ( item 1 of pxl + item 2 of pxl + item 3 of pxl ) / 3
report list gray gray gray item 4 of pxl

```

Since (in this case) 172800 pixels have to be edited, switching to the *turbo mode* of *Snap!* or using the *warp* block is worthwhile.

We want to create a black-and-white image from the grayscale image. To do this, we specify a threshold value. All gray values greater than the threshold value are set to white, the others to black. For this we write a function which is executed by *map... over*.

```

switch to costume house
set costume to copy of current costume
set pixels to pixels in costume
set width to get width of costume
set height to get height of costume

```



In the black-and-white image, some repair work should be carried out: single isolated points should be deleted, line gaps closed, etc. (see *tasks*). That's what we're doing without here. In the last step, we look for edges in the black and white image. To do this, we examine the area around each pixel. If all dots have the same color as the pixel, this is located within an area and is drawn white. If there is at least

+ edge + detection +

script variables
width height x y xp yp different value1 value2 copy
i

warp

```

set copy to list
set i to 1
repeat until i > length of pixels
  add item i of pixels to copy
  change i by 1
set width to get width of costume
set height to get height of costume
set x to 1
repeat until x > width
  set y to 1
  repeat until y > height
    set value1 to item 1 of getRGB from pixels at x y
    set different to false
    set xp to x - 1
    repeat 3
      set yp to y - 1
      repeat 3
        if xp > 0 and xp < width + 1 and
           yp > 0 and yp < height + 1 and
          set value2 to item 1 of getRGB from pixels at xp yp
          if not value1 = value2
            set different to true
        change yp by 1
      change xp by 1
    if different
      setRGB 0 0 0 at x y in copy
    else
      setRGB 255 255 255 at x y in copy
    change y by 1
  update costume with copy
  switch to costume costume
  change x by 1
set pixels to copy

```

```

gray of pxl : --> b&w + threshold t # +
if item 1 of pxl > t
  report list 255 255 255 item 4 of pxl
else
  report list 0 0 0 item 4 of pxl

```



one different pixel, we have found a border pixel and color it black. Because pixel value changes affect the neighborhood, the changes are copied to another list *copy*. Finally, this list is assigned to the variable *pixels*.

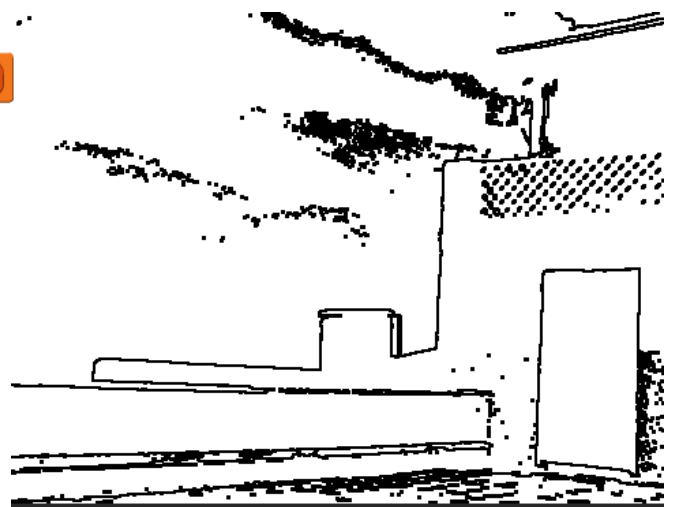

8.7 Tasks

- Find out more about the **C-curve** on the Internet.
 - Try out** some steps to construct the curve "by hand".
 - Implement a script to draw the curve by *Snap!*
 - Proceed accordingly for the **Dragon** curve, the **Peano** curve, and the **Sierpinski** curve.
- Display the RGB cube **from a different viewpoint** so that the three previously hidden sides become visible.
- If you want to try some JavaScript: create color gradients and the RGB color cube in a **JavaScript function**.
- Create blue **color excerpts** from galaxy images and check the statements about the young stars.
- Change the color values iteratively, i.e. without the map function, by accessing the individual pixels. Measure the **execution times** for different procedures.
- Some painters apply the colors with a **spatula**. Create "spatula images" that can "leak" in one direction and contain multiple colors. Create random pictures with a spatula.
- In black and white images, delete **isolated pixels**.
 - If you delete all **border points** in black and white images (the edges "melt down") and then add them to all border points again - or vice versa - you can delete single pixels, close gaps in lines, etc. by alternating and if necessary repeating the procedure. Implement the procedures and test them.
- If you want to program in JavaScript:
 - Implement the conversion of **grayscale images** to black-and-white images as JavaScript function. The threshold value should be given by a variable in slider representation.
 - Implement the **edge detection** as JavaScript function.
- Extrasolar planets are usually discovered when they darken their sun a little passing between their star and the earth. Get a picture of the sun and let a black circle, the planet, pass in front of the sun. Count the number of visible bright pixels and display the results of the **planet transit** in a diagram.

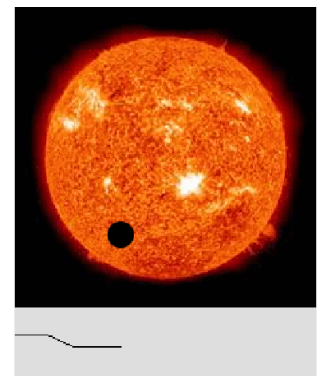

9 Image Recognition

The following three examples illustrate a sequence in which some *of Snap!'s* abilities for image processing are shown as the level of difficulty increases. Problems have been chosen that provide access to the current discussion of digital media. They are therefore relevant for the field of *"computer science and society"*.

9.1 A Barcode Scanner²³

Contents:

- different objects and communication procedures
- simple lists
- simple algorithmic structures
- scopes of variables and methods

We want to analyze a barcode (barcode) as it is used on the labels of goods in a supermarket by means of a "laser" (a red dot) and convert it into a character string. First of all, let's take a look at the planned setup, but don't overlook the very small red dot on the left side of the workspace - that's the "laser"!



What is an EAN code?

The European Article Numbers (EAN) code is available in different variants. Here we consider the EAN-8 code, which consists of 8 digits, the last one representing a check digit.²⁴ The numbers are represented by four black and white stripes of different widths. The space between two black lines is also part of the code! To the left and right of the barcode there are two black and one white stripes in between as a limiter. The center is marked by five such stripes. All have the width "1". The code has been selected so that all digits in total have the width "7". We will not go into any further details here.

To determine the coded numbers, the laser point is guided from left to right over the code. He "measures" the positions of the color changes and enters them in a list. From this the line widths are calculated. Since the first three lines have the width "1", we can determine this value quite well by averaging. The other line widths are multiples of this unit. In each case four dashes result in the code of a number, which we determine based on the table. The procedure can be briefly summarized in the form of a Nassi-Shneiderman-diagram.

EAN-8- Codetabelle	
cipher	Code
0	3211
1	2221
2	2122
3	1411
4	1132
5	1231
6	1114
7	1312
8	1213
9	3112

²³ partly from E. Modrow, The SQLsnap supermarket, Scratch2015 Amsterdam

²⁴ see e.g. https://de.wikipedia.org/wiki/European_Article_Number

determine the x positions of the edges of the black and white lines
calculate the line widths, delete the markers
calculate the eight four-digit codes
calculate the EAN code

Implemented as *Snap!*-script of the laser we get:

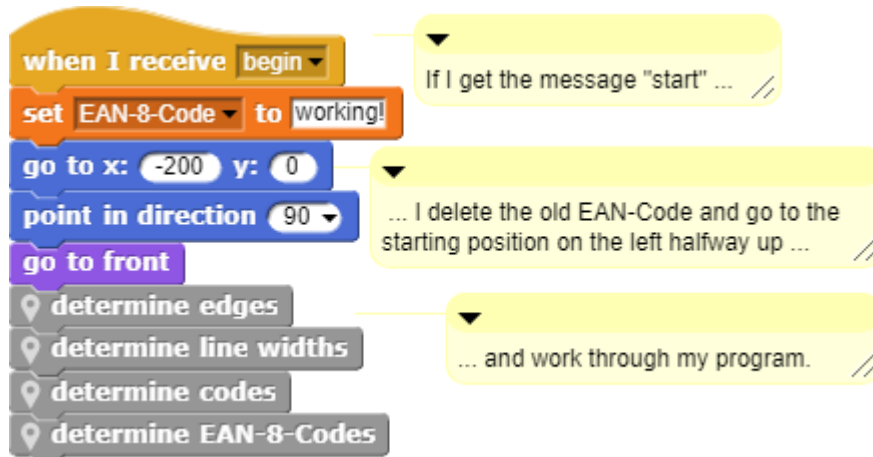

To do this we press the button "Make a variable" in the *Variables* palette of *Snap!*, enter the variable name *EAN-8-Code* in the pop-up window and mark this variable as local ("for this sprite only"). Since it is not used in any other object, we limit its validity to the scripts of the laser. The variable appears in the variable palette. Because we are already there, we also create three other variables with the names *edges*, *line widths* and *encoding*. The check mark in front of the EAN-8 code variable means that the variable is displayed in the output window. There we can change their appearance in the context menu (right click on the variable). The first block under the variable name *set <variable> to <value>* is dragged into the script area. Using the small black arrow, we can select a variable identifier visible to the laser and enter a value for it. If we click on the block, it is executed, and the variable gets the desired value, which is immediately visible in the output area.

After these preparations we must start to solve the real problem. One thing we have to teach the laser in any case: finding the next black line. We switch to the costumes area and draw a small red dot as a new costume - the laser dot. Alternatively, we can create the costume in a graphics program, save it as a *png* file and drag it to the *Costumes* area. With the help of the *touching <color>* block from the *Sensing* palette, we can now check whether our laser sprite touches the specified color. This color can be selected from the *Snap!* window or from the color box that opens after clicking on the color field in the block. We use this block and a second one, which determines whether the edge of the working area has been reached, as a termination condition for a loop (from the *Control* palette) in which the laser sprite is moved one step to the right at a time.

blocks of the *Variables* palette



```
repeat until touching black ? or touching edge ?
  move 1 steps
```

When testing this block, we find that the laser sometimes does not move at all. During repeated overflowing of the

strokes it will happen that the laser touches a white strip on one side, but on the other side it will still touch a black strip. After all, it has an extension, albeit a small one. We are therefore making sure that it advances to the point where it no longer affects black areas. Then he runs off.

```
repeat until not touching black ?
  move 1 steps
repeat until touching black ? or touching edge ?
  move 1 steps
```

After thoroughly testing this script, we pack it into a separate method, a new block called *go to the next black pixel*, which is labeled as local because no one else needs it. (How this happens is described in 2.7.1.) After that we create a very similar method, *go to the next white pixel*. The comment blocks can be found in the context menu after right-clicking on the script area.

```
+go to the next black pixel+
repeat until not touching black ?
  move 1 steps
  if necessary, leave last color
repeat until touching black ? or touching edge ?
  move 1 steps
  Continue to black or at edge
```

```
+go to the next white pixel+
repeat until not touching white ?
  move 1 steps
  if necessary, leave the last color
repeat until touching white ? or touching edge ?
  move 1 steps
  Continue to white or edge
```

We test the interaction of these two methods in detail. Afterwards, we make sure that the value of the variable *edges* is an empty list (*set <edges> to <list>*) and that the x-position of the laser is added to this list (*add <x-position> to <edges>*). We delete the last two values of this list, because they are generated when reaching the border. We can observe the behavior of this script if we mark *edges* with a small tick as visible. Since everything works well, the script will be packed in a new block to define the margins.

```
+determine edges+
set edges to list
repeat until touching edge ?
  go to the next black pixel
  add x position to edges
  go to the next white pixel
  add x position to edges
delete last of edges
delete last of edges
  delete old values
  search for the next border alternately
  Delete the last two values because they originate from the edge of the screen
```

Now there are three very similar methods, each of which runs through the last list just created to determine the next values. We process the first values of the lists and then delete them until we are through.

```
+determine line widths+
set line widths to list
repeat until length of edges = 1
  add item 2 of edges - item 1 of edges to line widths
  delete 1 of edges
```

First of all, we calculate the widths of the scanned lines as differences in the values of the *edges* list and save them in the *line widths* list. We then determine the encoding displayed by averaging the width "1" from the first three line-widths and storing them in the script variable *width 1*, which is only known within the new block. We delete the initial marking and calculate the first 16 line-widths for the first four numbers. After that we delete the middle mark and proceed accordingly for the second four numbers. The rest of the list is deleted. The determined values are stored in the *encoding* list.

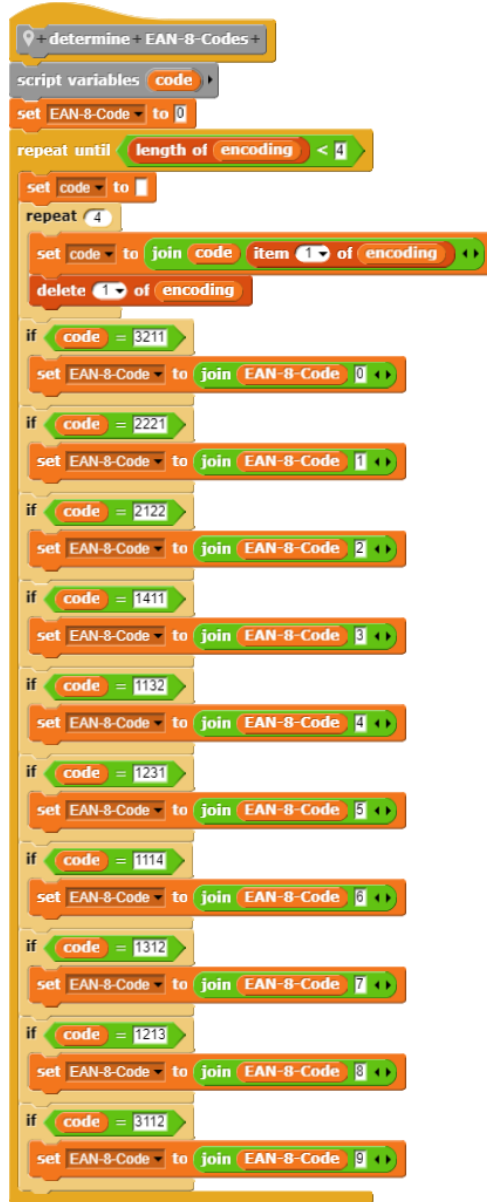
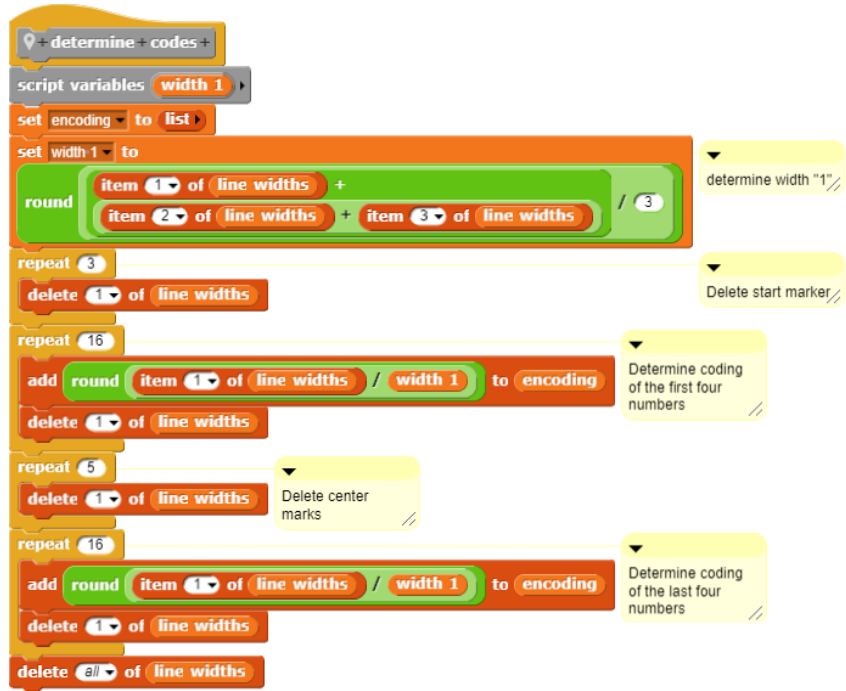

Now all what is missing is the decoding of the numerical values in the *encoding* list. We declare again a script variable *code* for the new block. This is repeatedly composed of four numerical values (with the join block from the *Operators* palette, which works with strings). Depending on the value of the result, we receive the next digit of the EAN code.

Our new blocks, which we can use like any other command block on the laser-script level, can be found at the bottom of the *Variables* palette. The small marking needle in front of the method names indicates that the methods are local for sprite. In other sprites they are not visible.

We create the barcodes with one of the generators for this on the internet and save them as costumes of a new sprite, which we create with the arrow button above the sprite area at the bottom-right of the window. We call this Sprite *Barcode*. To switch between the costumes, we create a global block showing a barcode (to show this way of communication between objects). This doubles the size of the costume and puts the sprite in the middle. The block can be seen on all sprites.

blocks of the Operators palette



Our little project will be controlled by stage scripts. When the green flag is clicked, the *Barcode* object is asked to display a new barcode - i.e. to change the costume. This is done with *tell <Barcode> to <show a barcode>*.

Since the block to be executed is declared as global, surrounded in gray and so marked as a code, we can simply drag it into the previously empty slot in the *tell* block²⁵. Then the stage sends the message "begin" only to the laser object. Alternatively, it could have sent this message to everyone. If only the *Laser* sprite reacts, then this would have the same effect.

The last two scripts are used to initiate costume changes by pressing the space bar and reading by clicking on the stage.

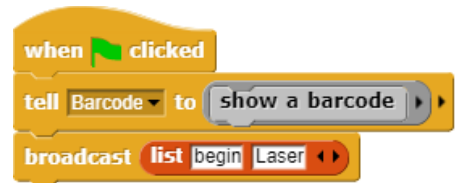
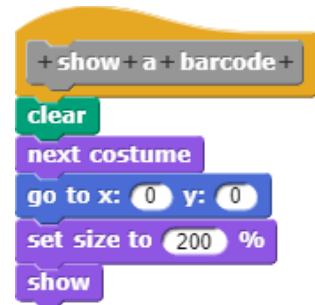

²⁵ Another way to call methods of an object is described in 2.7.3.

9.2 Project: Transit prohibited!

Contents:

- export and import of sprites
- access to pixels
- using a library
- simple algorithmic structures

Modern cars have a camera that enables them to "see" and recognize traffic signs. We want to try something like that. We search for the pictures of some common traffic signs and scale them all to the size of 100 x 100 pixels with the help of a graphics program. After that we drag them into the *Costumes* area of a *Snap!* sprite that we call *Traffic sign*.

As you can see, the signs are quite different. Therefore, one task will be to recognize the shape of the shield. We find *round*, *rectangular* and *different triangular* signs. Fortunately, we already have a laser from the last project at our disposal, which we will modify for the new task. To do this, we export the *Laser* sprite from the barcode project to an XML file *Laser.xml* (right-click on the sprite, click "export..." from the context menu) and import this file into the new project either using the file menu or by dragging it onto the *Snap!* window. In the *Variables* palette of the laser we delete all variables except for *edges*, then we delete the local methods except *go to the next black pixel*. We open it in the block editor (right click on them), drag the blocks to the script level and delete this method too.

How do we distinguish the shapes of the signs?

You can come up with very different methods for this. We'll try this: The horizontal boundaries of the signs are defined in three heights and then the vertical ones at three positions. Then we'll look at the results.

First the left edges ...

```

set edges to list
wait 0.1 secs
set xValue to 70
set yValue to 33
add left-edges to edges
repeat 3
  go to x: xValue y: yValue
  point in direction 90
  go to front
  repeat until not touching
  move 1 steps
  add round x position to edges
  change yValue by -33

```

then the right ones ...

```

set xValue to 70
set yValue to 33
add right-edges to edges
repeat 3
  go to x: xValue y: yValue
  point in direction -90
  go to front
  repeat until not touching
  move 1 steps
  add round y position to edges
  change yValue by -33

```

... and correspondingly the upper and lower ones.



The four scripts are put together and packed in a method *determine edges*. For example, we get the following results.

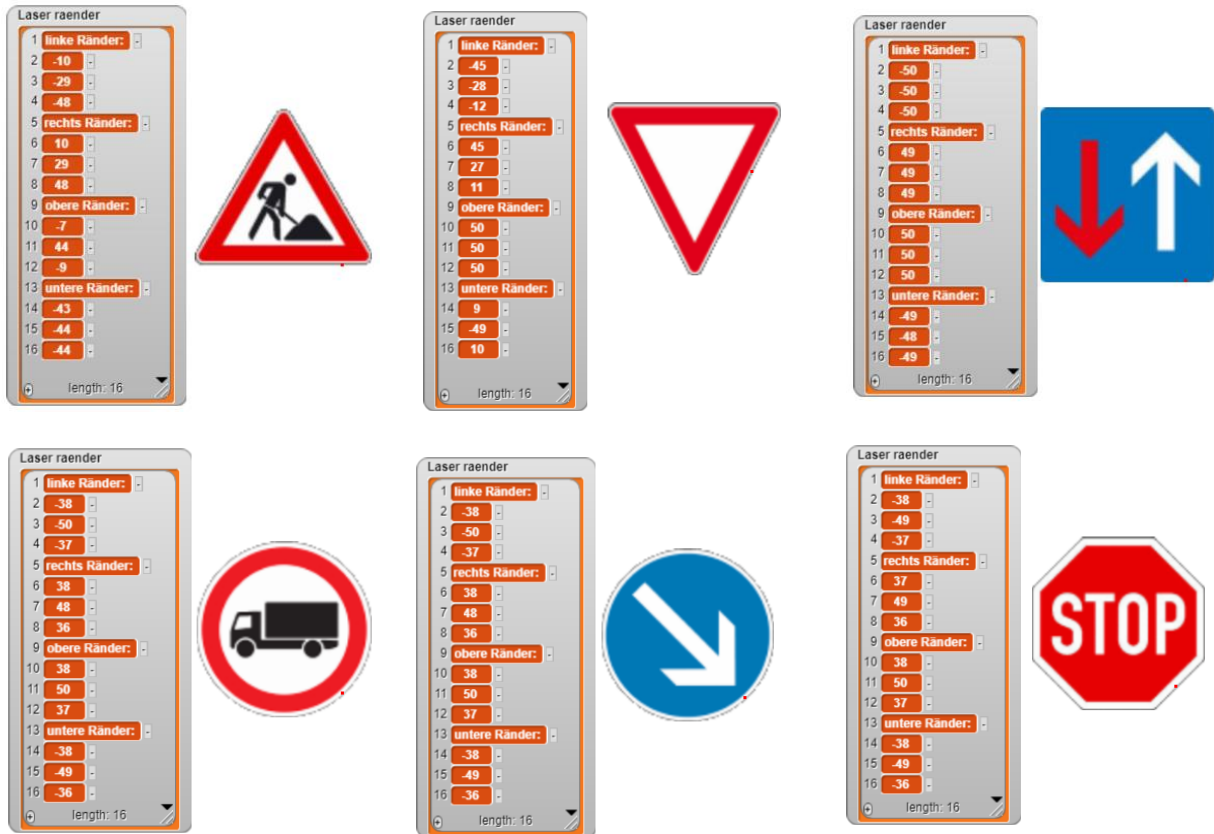

That looks quite good - except for the stop sign. Its edges are suspiciously similar to a round sign; we have to come up with something else. Perhaps a 13th "cut" at a suitable place (here: fourth, in the list: fifth)? For that we can omit the right edges, because the signs are obviously symmetrical. If we do that, we get for the "round" candidates:

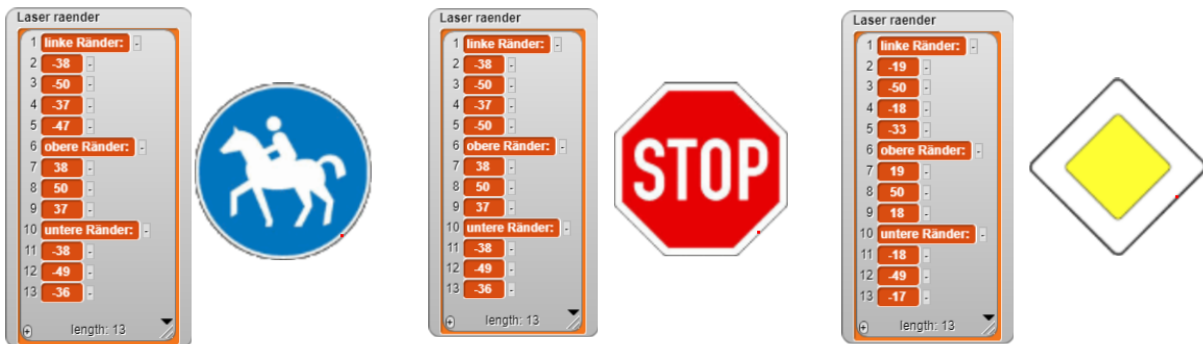

The 5th list entry contains the value for the height 19 - and thus a measurable difference.

For the evaluation of our results we write a block *determine shape*. This should be a reporter block that determines and returns a value - the shape.

- For rectangular signs, the entries 2, 3 and 4 should be approximately the same.

```

if
  abs of item 2 of edges - item 3 of edges < 2 and
  abs of item 3 of edges - item 4 of edges < 2
  set shape to square
else

```

- The values of the triangular signs increase or decrease.

```

if
  item 2 of edges > item 3 of edges and
  item 3 of edges > item 4 of edges
  set shape to triangular-tip-top
else

```

```

if
  item 2 of edges < item 3 of edges and
  item 3 of edges < item 4 of edges
  set shape to triangular-tip-down
else

```

- If we assume a round shape (the second and fourth entry should be about the same size), then it is the octagon of the stop sign, if the third and fifth entry are about the same size, the rhombus of the priority sign, if the second entry is quite small and otherwise a round sign. And of course, errors can occur.

```

if abs of item 2 of edges - item 4 of edges < 2
if abs of item 3 of edges - item 5 of edges < 2
  set shape to octagonal
else
  if abs of item 2 of edges <
    abs of item 3 of edges / 2
    set shape to rhombic
  else
    set shape to round
else
  set shape to ERROR!

```

Finally, a block comes to the script that returns the determined shape as a function result.

```
report shape
```

So, we have already limited the number of possibilities quite a bit, and we see that - at least so far - we are getting by with the results for the left margin. We write a local method *shape?* of the laser that determines the shape of the just presented traffic sign. In addition, the laser is sent "into the heath" and hidden so that it does not disturb any further. His work is done.

```

+ shape? +
script variables result
set result to ask Laser for determine shape of Laser
go to x: -300 y: 0
hide
report result
    
```

For the meanings of the signs, the colors on the edge and inside are important. To analyze them, we use the library *Pixels*, which we find in *File menu* → *Libraries*. This will deliver new blocks that we find below the *Make a block* button in the corresponding palettes.

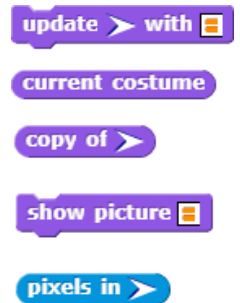

For the final determination of the type of traffic sign we simply want to count the number of different colored pixels in the sign. Maybe that's enough. We leave this work to a new object called *Color Counter*. This requires at least a copy of the current costume of the traffic sign. We kindly ask them for the required data, which we store in a local variable *sign*. In a second variable named *pixels* we save a list of the three color values and the transparency of the pixels of the received costume. Since it has the size 100 x 100, we get 10000 entries.

In this list, the pixels outside of the actual tag have the transparency 0, inside the value 255. The three RGB values do not represent "pure" colors, but mixed values, which are for example "predominantly" red. We change this with a method *change to pure colors*, which sets the color values above 100 to 255, the other to 0. This takes quite a long time with 10000 values, because the list is "refreshed" every time. For this reason, we pack the operations into a *warp* block that does not update the display until the end. The speed improvement is extremely high.

```

+ change to pure colors +
script variables i aPixel
warp
set i to 1
repeat until i > length of pixels
  set aPixel to item i of pixels
  if item 1 of aPixel > 100
    replace item 1 of aPixel with 255
  else
    replace item 1 of aPixel with 0
  if item 2 of aPixel > 100
    replace item 2 of aPixel with 255
  else
    replace item 2 of aPixel with 0
  if item 3 of aPixel > 100
    replace item 3 of aPixel with 255
  else
    replace item 3 of aPixel with 0
  replace item i of pixels with aPixel
  change i by 1
    
```

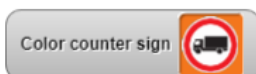

Color counter pixels				
10000	A	B	C	D
1173	237	28	36	255
1174	237	28	36	255
1175	237	26	34	255
1176	238	49	54	255
1177	251	210	212	255
1178	253	253	253	255
1179	253	253	253	255
1180	253	253	253	255
1181	238	235	236	255
1182	138	137	137	255
1183	0	0	0	0

Similarly, we let the "pure" colours count in the picture: We will introduce a separate script variable for each of them, which we will initially set to zero. Afterwards we look at all pixels of the sign that have a sufficient transparency. For these, we analyze the RGB values and increase the value of the correct variables. Finally, we'll return a list of the results in which we'll add the color names so that we don't get confused.

Color counter colors

8	1	B
1	black	0
2	white	1544
3	red	6296
4	green	0
5	blue	0
6	yellow	0
7	cyan	0
8	magenta	0



Color counter colors

8	A	B
1	black	81
2	white	3052
3	red	2534
4	green	0
5	blue	0
6	yellow	0
7	cyan	0
8	magenta	0



Color counter colors

8	1	B
1	black	121
2	white	2249
3	red	0
4	green	0
5	blue	0
6	yellow	0
7	cyan	5482
8	magenta	0



```

+count+ colors+
script variables
red green blue black white yellow cyan magenta i
aPixel

warp
set red to 0
set green to 0
set blue to 0
set black to 0
set white to 0
set yellow to 0
set cyan to 0
set magenta to 0
set i to 1

repeat until i > length of pixels
  set aPixel to item i of pixels
  if item 4 of aPixel > 128
    if item 1 of aPixel = 255 and
       item 2 of aPixel = 255 and item 2 of aPixel = 255
      change white by 1
    else
      if item 1 of aPixel = 255 and
         item 2 of aPixel = 255 and item 2 of aPixel = 0
        change yellow by 1
      else
        if item 1 of aPixel = 0 and
           item 2 of aPixel = 255 and item 2 of aPixel = 255
          change cyan by 1
        else
          if item 1 of aPixel = 255 and
             item 2 of aPixel = 0 and item 2 of aPixel = 0
            change red by 1
          else
            if item 1 of aPixel = 0 and
               item 2 of aPixel = 255 and item 2 of aPixel = 0
              change green by 1
            else
              if item 1 of aPixel = 0 and
                 item 2 of aPixel = 0 and item 2 of aPixel = 255
                change blue by 1
              else
                change black by 1
          else
            change i by 1
  report list black black list white white list red red list green green list blue blue list yellow yellow list cyan cyan list magenta magenta
  
```

For easy use of the methods we write a global method *colors?* which initiates the appropriate operations.

```

+ colors?+
set sign to ask Traffic sign for copy of current costume
set pixels to pixels in sign
tell Color counter to change to pure colors of Color counter
report ask Color counter for count colors of Color counter
    
```

We leave the control of the objects to the stage. When pressing the space bar, the traffic sign should change and when clicking the green flag, the analysis takes place. The Stage object queries the results of the others and evaluates their data.

```

when space key pressed
go to x: 0 y: 0
next costume
    
```

```

when clicked
set result to please-wait!
set theShape to ask Laser for shape?
set theColors to ask Color counter for colors?
evaluation
    
```

For the evaluation we use on the one hand the determined shape and on the other hand the counted color values. This can be done in a simple way:

The results are as desired.



```

+ evaluation +
script variables h
if theShape = rhombic
set result to main-road
if theShape = octagonal
set result to halt
if theShape = triangular-tip-top
set h to item 2 of item 1 of theColors
if h > 650 and h < 675
set result to construction-site
if theShape = triangular-tip-down
set h to item 2 of item 2 of theColors
if h > 3040 and h < 3060
set result to give-way
    
```

etc.

9.3 Project: Face Recognition

Contents:

- accessing single pixels
- using JavaScript
- more complex algorithmic structures

Face recognition is a good topic to discuss the social consequences of IT systems. Therefore, we want to use the capabilities of *Snap!* for this purpose. For good reasons, passport photos are strongly standardized: the facial posture is prescribed, ears must be visible, ... This makes facial recognition considerably easier. We therefore draw four faces that roughly correspond to these regulations. On these "photos" we apply the already known (and some new) methods.

We're looking for the face, and that's (nearly) "pink". Since the facial colours are different, we first carry out a reduction of the color space. We find suitable limits of the (here) three intervals by trial and error.

```

+ reduction+ of+ the+ color+ space+
script variables i n thePixel
warp
set i to 1
repeat until i > length of pixels
  set thePixel to item i of pixels
  set n to 1
  repeat 2
    if item n of thePixel < 192
      replace item n of thePixel with 0
    else
      if item n of thePixel < 224
        replace item n of thePixel with 128
      else
        replace item n of thePixel with 255
    change n by 1
  replace item 3 of thePixel with 0
  replace item i of pixels with thePixel
  change i by 1

```

The procedure is well known from traffic sign recognition in the previous section - we use the *Pixels* library. The faces now appear very beautifully orange - regardless of what they looked like before.

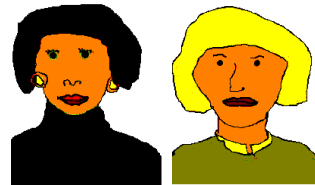

Peter



Paul



Mary



Hannah

If we delete all colors except orange, only faces should be left.

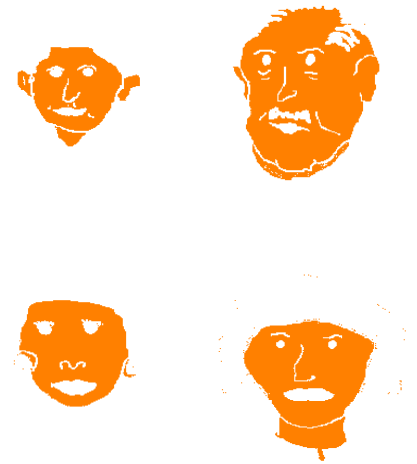
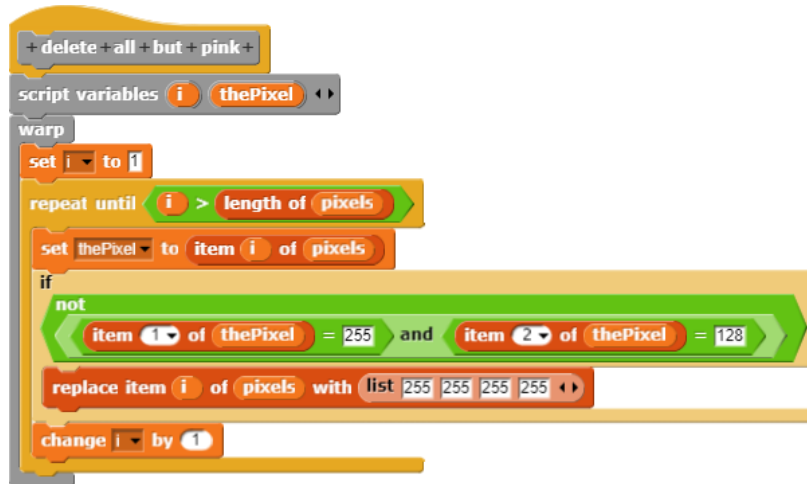

So that we don't always change the original pictures with our procedure, we first make a working copy of the current costume and delete it later on.

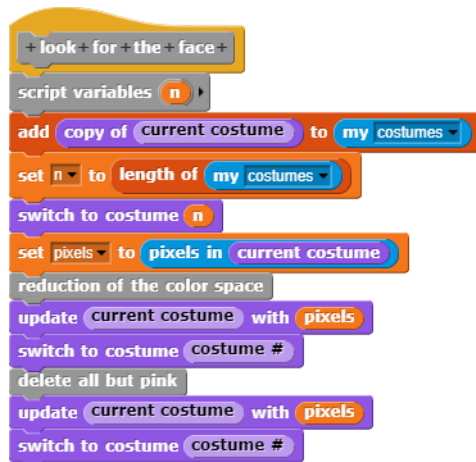

In these faces we now have to identify the eyes, mouth, nose, etc. From the proportions of the sizes *eye distance to nose length*, *mouth width to face height*, ... can be inferred on the person.

How to find eyes?

They represent "holes" in the face, which must not be too large or too small. The right eye (from the person's point of view) e. g. should be in the top-left of the passport photo. To do this, we first need to be able to access individual pixels in the image. We do this by using the JavaScript-Block, which we give the coordinates and the considered costume as parameters.²⁶ We select the type of parameters as described in 2.7.1: twice a number and once an object.

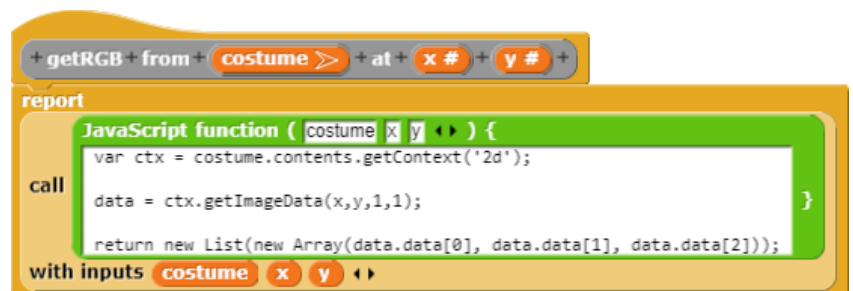

²⁶ There are other ways to do it.

We use it to search the upper-left image area for a "hole". We analyze the area of $44 < x < 86$, $89 < y < 121$.

```

set y to 90
set found to false
repeat until found or y > 120
  set x to 45
  set value to 255
  repeat until found or x > 85
    change x by 1
  change y by 1
  
```

We pass the white area and stop at the first orange pixel:

```

repeat until value < 130 or x > 85
  set value to item 2 of getRGB from current costume at x y
  change x by 1
  
```

Then we look for white.

```

repeat until value > 250 or x > 85
  set value to item 2 of getRGB from current costume at x y
  change x by 2
  
```

Was that really white? Otherwise it won't work with "eye".

```

set xpos to x
if value > 250
  if not found
    set x to xpos
  
```

We now count the white pixels horizontally in the variable n ...

```

set n to 1
set xp to x
set yp to y
set value to item 2 of getRGB from current costume at xp yp
repeat until value < 130 or xp > 85
  change xp by 1
  set value to item 2 of getRGB from current costume at xp yp
  change n by 1
  
```

If the gap was in the correct range ($5 < n < 30$), we do the same thing horizontally.

```

if n < 5 or n > 30
  set found to false
else
  set xp to round(x + n / 2)
  set value to item 2 of getRGB from current costume at xp yp
  repeat until
  
```

If the size fits here too, it was an "eye".

```

+look for the right eye+
script variables
x y found value xpos ypos xp yp n result
warp
set result to false
set y to 90
set found to false
repeat until found or y > 120
  set x to 45
  set value to 255
  repeat until found or x > 85
    repeat until value < 130 or x > 85
      set value to item 2 of getRGB from current costume at x y
      change x by 1
    repeat until value > 250 or x > 85
      set value to item 2 of getRGB from current costume at x y
      change x by 2
    set xpos to x
    if value > 250
      set n to 1
      set xp to x
      set yp to y
      set value to item 2 of getRGB from current costume at xp yp
      repeat until value < 130 or xp > 85
        change xp by 1
        set value to item 2 of getRGB from current costume at xp yp
        change n by 1
      if n < 5 or n > 30
        set found to false
      else
        set xp to round(x + n / 2)
        set value to item 2 of getRGB from current costume at xp yp
        repeat until value < 130 or yp > 120
          change yp by 1
          set value to item 2 of getRGB from current costume at xp yp
        set n to 1
        change yp by -1
        count vertical white pixels
        set ypos to yp
        set value to item 2 of getRGB from current costume at xp yp
        repeat until value < 130
          change yp by -1
          set value to item 2 of getRGB from current costume at xp yp
          change n by 1
        if n < 5 or n > 30
          set found to false
        else
          set found to true
          set yp to round(ypos - n / 2)
          set result to list(xp yp)
        if not found
          set x to xpos
          change x by 1
          change y by 1
      report result
  
```

The procedure is not very simple, but it is still feasible - above all since we can develop it step by step, because the intermediate results are easily to show.

For the left eye we search the upper right area very similarly, and the mouth should be in the lower half of the picture and be larger than an eye.

With the nose we make it very easy for ourselves: it starts in the middle between the eyes and runs to the first white pixel - whatever that is.

```

+ look for the nose + xstart # + ystart # +
script variables x y value result
set result to false
set x to xstart
set y to ystart
set value to 255
repeat until value < 130
  set value to item 2 of getRGB from current costume at x y
  change y by 1
repeat until value > 250
  set value to item 2 of getRGB from current costume at x y
  change y by 1
set result to list xstart ystart x y
report result

```

To check our results, we write a method *draw line*, which draws a line between two points in the image - again as a JavaScript function. We transfer the coordinates of the endpoints, the RGB-values of the desired color and the line thickness, as well as the edited costume.

```

+ draw line from xa # ya # to xe # ye # color r # g # b # on costume > width width # +
JavaScript function ( xa ya xe ye r g b costume width ) {
  var ctx = costume.contents.getContext('2d');
  ctx.beginPath();
  ctx.lineWidth = width;
  ctx.strokeStyle = new Color(r,g,b).toString();
  ctx.moveTo(xa,ya);
  ctx.lineTo(xe,ye);
  ctx.closePath();
  ctx.stroke();
}
with inputs xa ya xe ye r g b costume width

```

This allows us to easily draw small crosses into the picture:

```

+ mark point : +
draw line from item 1 of point - 5 item 2 of point to
item 1 of point + 5 item 2 of point color 0 255 0 on
current costume width 1
draw line from item 1 of point item 2 of point - 5 to
item 1 of point item 2 of point + 5 color 0 255 0 on
current costume width 1
switch to costume current costume

```

Don't drink too much coffee while you wait for the results! ☺

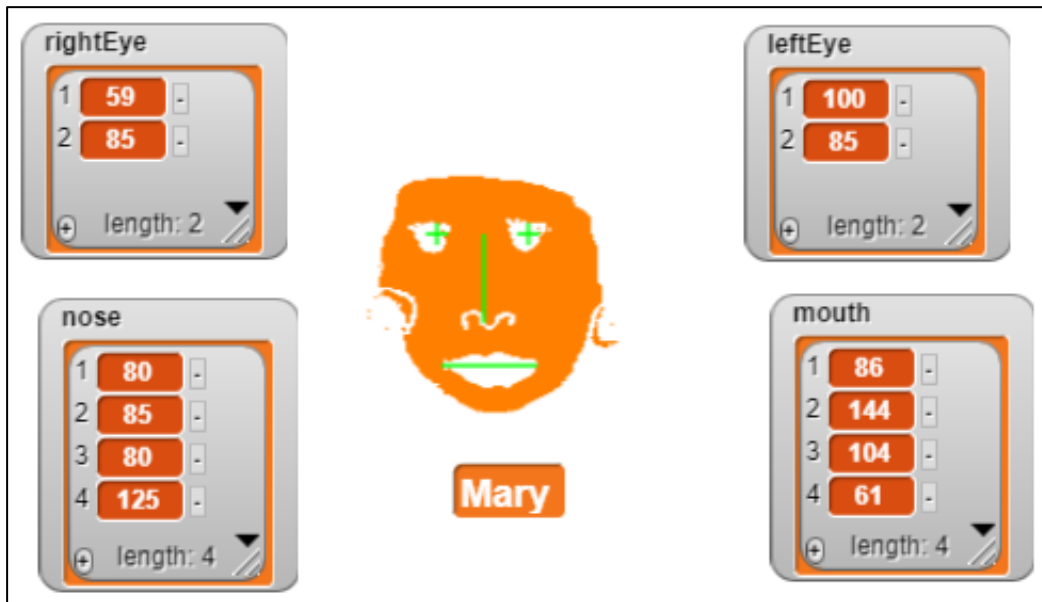

We calculate some ratios from the determined values and save them together with the names in a list *allAttributes*. By comparison with the currently determined values, the searched person can easily be identified.

Table view				
	A	B	C	D
1	Name	Mouth : Nose	Nose : Eye	Mouth : Eye
2	Mary	1.075	0.9756	1.04878
3	Hannah	1.2368	0.77551	0.95918
4	Peter	1.1111111	0.9	1
5	Paul	0.65789	0.926829	0.609756

Browse all stored records.

Test the current record for consistency.

Compare all properties.

Note failure.

Person was found, show name.

Otherwise, keep looking.

```

+identification+
script variables i n attributes found delta test
set delta to 0.05
set found to false
set i to 2
repeat until found or i > length of allAttributes
  set attributes to item i of allAttributes
  set test to true
  set n to 2
  repeat 3
    if
      item n of newAttributes < item n of attributes - delta or
      item n of newAttributes > item n of attributes + delta
    set test to false
    change n by 1
  if test
    set found to true
    set person to item 1 of attributes
  else
    change i by 1
  
```

The whole problem can be solved by combining the sub-problems. We assume that the image of the person to be identified is on the screen. This is copied, transformed and the changes are displayed. Then the original image is repainted.



The four people are safely identified.

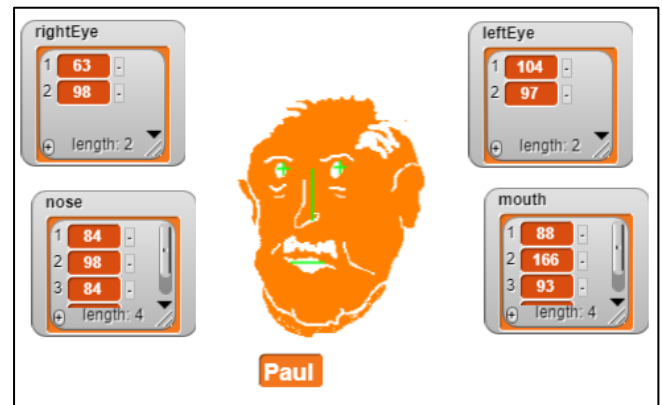

9.4 Tasks

1. a: Find out about the calculation of the **check digit** in the EAN-8 code. Use a few examples to test whether you have understood the procedure.
b: Let the barcode scanner check after each reading process whether the check digit has the **correct value**.
c: **Extend** the barcode scanner by further options: Codes can also be read "backwards", and there are also longer codes, e. g. EAN-13.
d: Get the manufacturer's and product numbers from the barcodes you have read. Enter the results in **plain text** on the basis of the corresponding data: "*Honey from the bee-farm*", ...
2. Develop a **barcode generator**. It is given a sequence of numbers and calculates the check digit from this and prints the barcode. This can be done, for example, with the help of appropriate costumes, which are printed on the stage in the right places using the *stamp* block from the *Pen* palette.
3. Have **foreign road signs** identified. Use the traffic signs to determine where a photo was taken.
4. A **speed warning device** is used in a car to determine whether the speed limit has been exceeded by means of traffic signs.
5. Intelligent scales (smart scales) contain a camera to detect fruits. Start with fruits you have drawn and then move on to real photos.
6. German **car license plates** contain a character set that is very suitable for image recognition (uniform character width, ...). Develop a procedure that recognizes vehicle license plates. Discuss the consequences.
7. **Face recognition** can be found today when you log on to a computer system, in cameras and smartphones, in social networks, ... Find out more about other applications and discuss the results.
8. In some countries, a system of **social credits** is being introduced or the introduction is discussed. Find out more about the system and discuss the consequences of extensive video surveillance.

10 Sounds²⁷

Contents:

- playing and recording sound
- visualization of sounds
- music

Similar to animated graphics, it is a bit difficult to describe how sounds are handled. Therefore, only the different possibilities are presented here - with the urgent recommendation to try out and experiment with the "code snippets".

10.1 Find Sounds

First of all, you need a sound in *WAV* format. To do this, you can either import the file using the File menu (*File* → *Sounds...*) ...

.... or, as usual, drag it "from outside" into the *Snap!* window ...

... or just record it yourself. This can be done - for short recordings - directly using the *Snap!* sound recorder on the *Sounds* page. For longer recordings you should use one of the common tools.

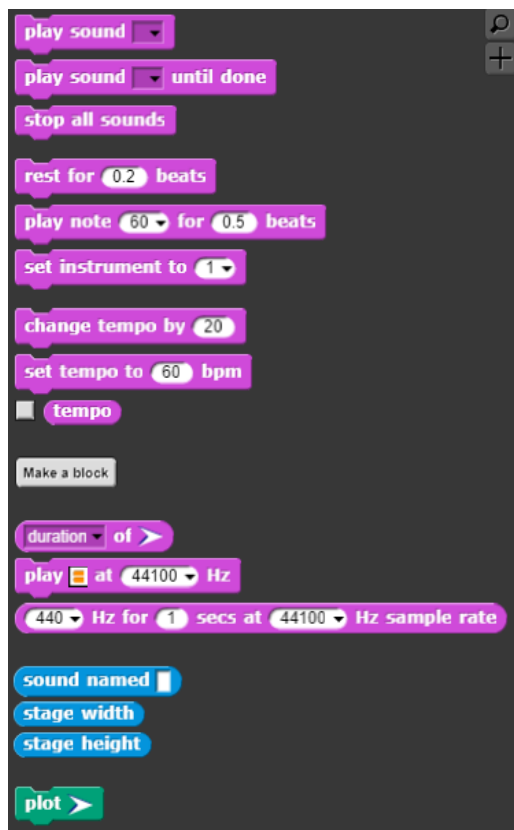

For further editing we load the library *Audio Comp* from the File menu. This means that the adjoining blocks from the *Sound*, *Pen* and *Sensing* menus are available to us.

Below we work with the file *soundtest.wav*, which we have created in one of the described ways.



²⁷ Following the example "music" by Jens Mönig

10.2 Processing Sounds

If there is a sound on the *Sounds* page, it will be displayed in the corresponding blocks. The easiest way to try this is to use the blocks for playing sounds.

For further processing we need a representative of our sound. The block *sound named <soundname>* is meant for this purpose. If you edit this, you have found a small example of how to use the sound blocks.



The *of* block for sounds provides access to other sound properties. In particular, its *samples*²⁸ can be determined as a list. These are needed if you want to actively edit a sound. For example, we can influence the playback speed of the sound by changing the sample rate. The *Hz for...* block generates samples with the specified properties, e. g. "pure tones".

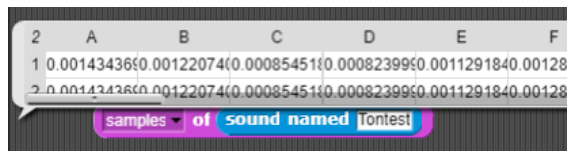

The visualization of the sounds is interesting. With the *plot <sound>* - block we get a graphic of the sample on stage.²⁹

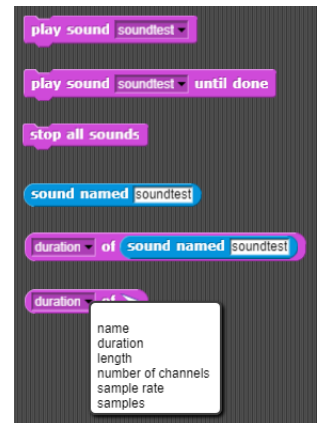
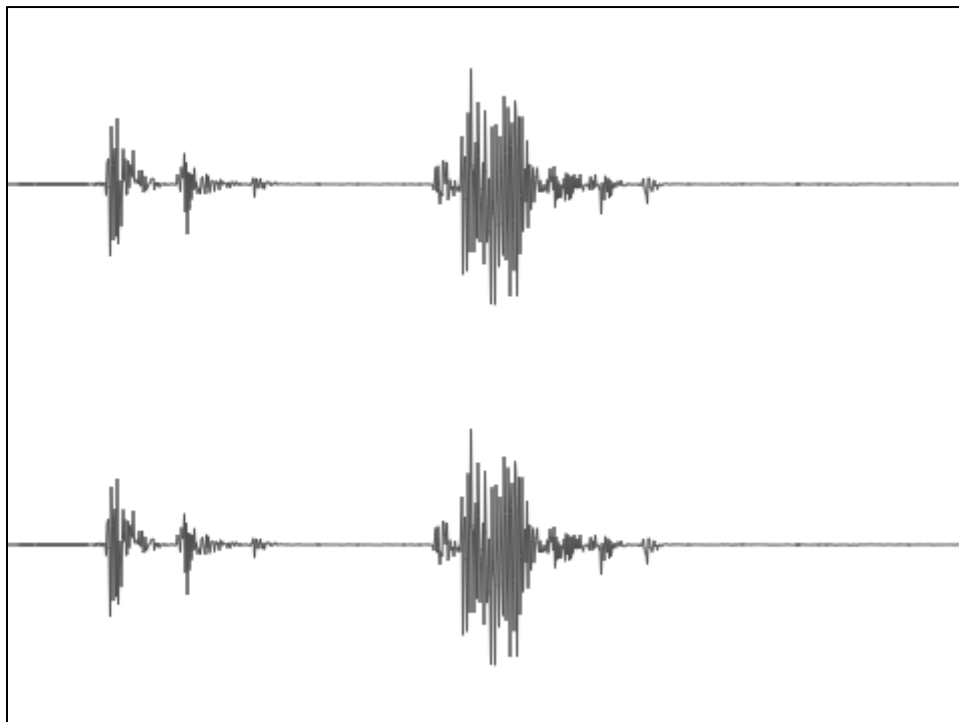

²⁸ <https://de.wikipedia.org/wiki/Abtastrate>

²⁹ The same applies to (almost) all other sound blocks. If you edit them, you will find examples of Java-Script for example.

10.3 Making Music

A sample consists of a list of numbers and stereo sounds from a two-element list of samples (see above). As a result, sounds can be manipulated with the usual list operations, such as inverting, changing the value, ...

Songs can also be composed of notes, even very comfortable. The note is selected on a piano keyboard. This can quickly be used to compose songs ...

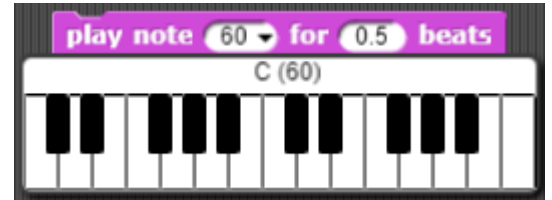

... and to play it on different instruments and in different tempi.



If you play several notes in parallel, chords are created ...

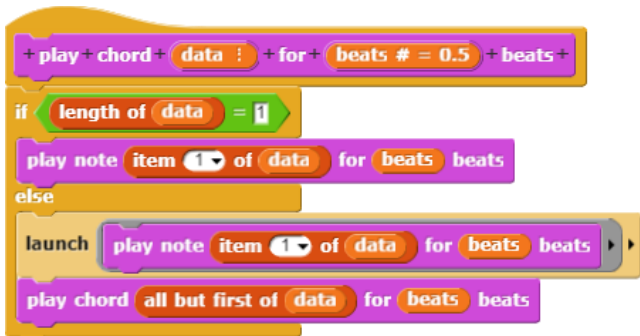
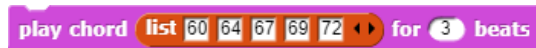

... and these songs can be played and varied ...

... using a suitable list of pairs of (note, duration).

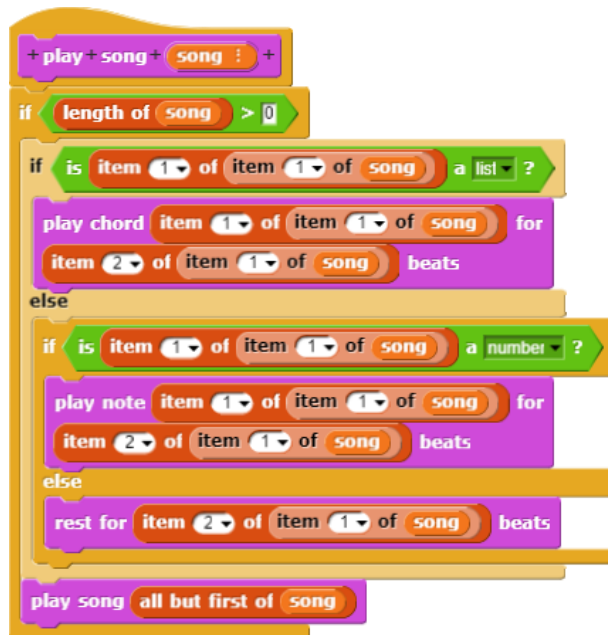

set two basic chords

describe bass accompaniment and song by lists of tone / duration pairs

make a few adjustments

to play the song, the chord and have a short break

and now play the song and bass accompaniment over and over again with variations

both play in parallel because of the *launch* block

```

when clicked
  script variables maj min song bass delta
  set maj to list 60 64 67 69 72
  set min to list 60 63 67 69 72
  set bass to
    list 2
    list 60 1
    list 64 1
    list 67 1
    list 69 1
    list 72 1
    list 69 1
    list 67 1
    list 63 1
    list 60 2
    list 64 1
    list 1
    list 55 1
    list 57 1
    list 60 2
    list 58 1
    list 59 1
  set song to
    list
    list 7
    list 64 3
    list 67 7
    list 69 3
    list maj 1.5
    list 5
    list maj 7
    list 60 3
    list 64 7
    list 67 3
    list min 1.5
    list 5
    list min 7
    list 60 3
    list 63 7
    list 67 3
    list map + 5 over maj 5
    list map + 7 over maj 2
    list 2
    list 79 3
    list 76 7
    list 72 3
    list 75 7
    list 74 3
    list 72 7
    list 67 3
    list maj 5
    list map - 2 over maj 2
    list map - 1 over min 1
    list 0.8
  set turbo mode to checked
  set tempo to 150 bpm
  set instrument to 4
  play song song
  play chord maj for 3 beats
  rest for 1 beats
  forever
    set delta to pick random -12 to 20
    set instrument to pick random 1 to 4
    if item random of list true false
      launch
        set instrument to pick random 1 to 4
        play song song bass transposed by delta mod 12 - 24
    play song song song transposed by delta
  
```

10.4 Project: Hearing Check

A hearing check tests the hearing ability at different frequencies, but also at different volume levels. In a simple case we play tones of increasing frequency until the respondent hears something. Then he (or she) presses the space bar. This frequency *min* is noted. After that, the frequency is increased until nothing more is heard. This frequency is also stored.

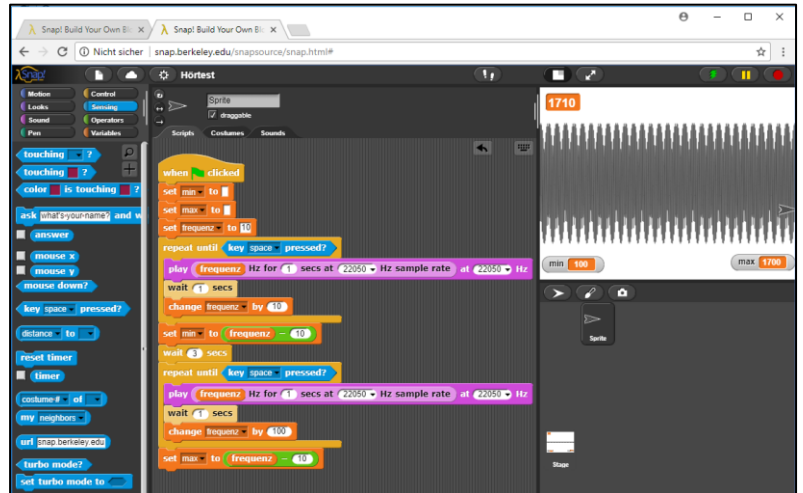

Make sure that the volume is not too high!



10.5 Tasks:

1. Define test conditions that lead to comparable results.

2. Change not only the frequency, but also the volume. Since our sounds are described by samples, the volume can be changed by simply multiplying the sample values. For example, in the following script the volume is increased until the space bar is pressed. Attention: The volume should not be too loud!



3. Measure the cut-off frequencies and the volume per frequency required for listening. Create a diagram based on the data.

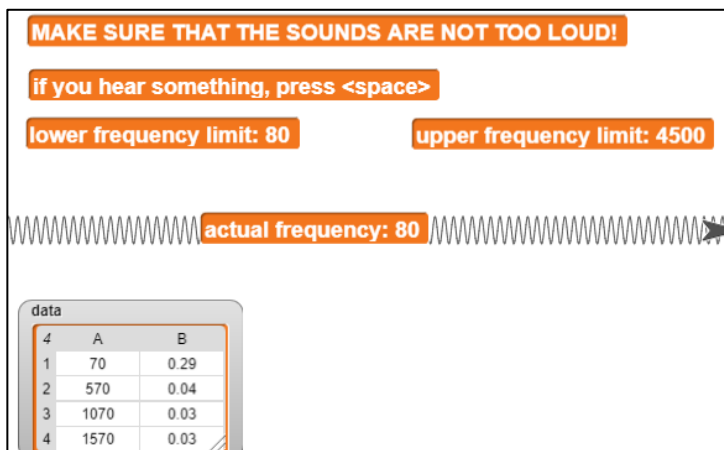

4. Make an excursion to an ENT practice/clinic. Present your diagrams and let yourself be explained if and what you can read from them. Find out about the causes of possible hearing loss.

11 Project: Electrons in Fields

We want to use the knowledge we have gained so far to realize a small project in the field of - well - physics: Electrons move in a tube with a capacitor built into it. This tube is placed inside a pair of Helmholtz coils so that the electrical and magnetic fields are perpendicular to each other. Both are reasonably homogeneous. This is one of the standard high school experiments. All components can be developed independently of each other in different groups and in very different ways. Only physics stays the same. That's the way it is with physics. 😊

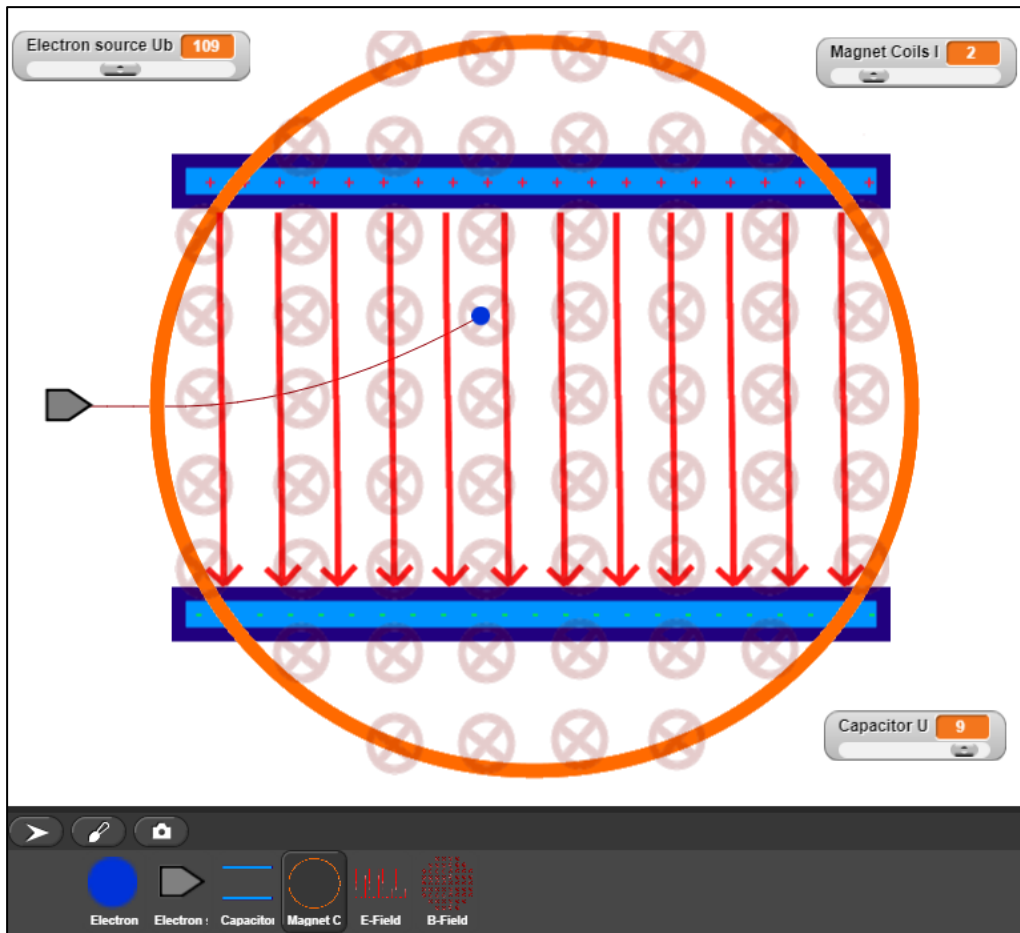

11.1 Electron Source and Set-Up

Since this is a standard experiment, the required devices should be found in the physics collection. It is therefore a good idea to construct the experiment in a clearly arranged way, photograph it and extract the partial devices from the images in such a way that they can be used in the project. Here in the script only simple drawings were made instead. We need images of the capacitor, the coils, the electron source and - for illustration - the generated fields.

First of all, we enlarge the stage from *Snap!* to 800 x 600 pixels. There is a menu item in the *Settings* menu of *Snap!*. Then we draw a simple picture of an electron source and import it as a costume of the current sprite.

After starting the program with the green flag, our electron source is sent to its place in the correct costume. If necessary, we can also move them to another place in the experiment. The device has only one characteristic feature: the momentary acceleration voltage of the emitted electrons. To do this, a local variable U_b is created and displayed on the stage. In the context menu of this display (the *monitor*) you can select *slider* and set the minimum and maximum value. With the slider, the variable value is changed between these values in the running program. We choose a range between 0 and 250 volts.

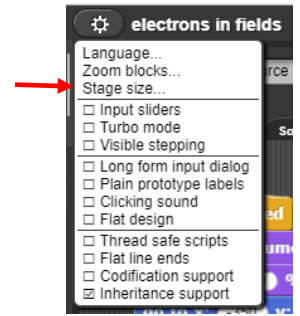

11.2 Capacitor and Electric Field

The capacitor in the tube has a plate spacing d , which we set fixedly so that a realistic electron movement results later on. Once it has found its place, it runs continuously until the program terminates. If we set the applied voltage U to zero, it should disappear so that we can examine movements only in the magnetic field - it would only disturb. For U and d we set up local variables. The capacitor informs the electric field *E-Field* about its current value. This is done by setting the value of its local variable E with the value U/d in the context of the *E-field*.

In fact, the following applies:

$$E = \frac{U}{d}$$



After that it sets the *ghost-effect* of the electrical field, i.e. its transparency, to a value that depends on the applied voltage in the same way. The smaller it is, the more translucent appear the arrows that symbolize the electric field.



without applied voltage the capacitor disappears //

calculate current electric field strength //

visualize electric field strength //

Important: the field of the value in set <variable> to <value> must be really empty so that it can be replaced by the specified size!

The electric field, another sprite of its own, simply consists of a costume containing a series of parallel arrows that fit between the capacitor plates. It has a local variable E , which is set by the capacitor as described. The voltage of the capacitor is displayed as a slider variable on the stage.

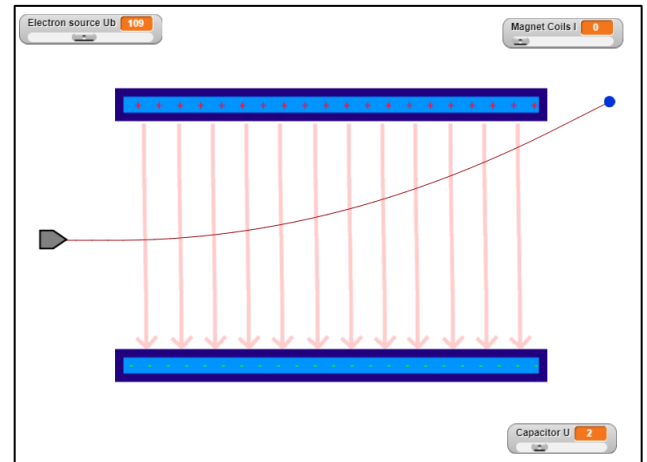

11.3 Helmholtz-Coils and Magnetic Field

The Helmholtz coil pair is symbolized by a simple circle on the stage.³⁰ It contains a local variable B , the magnetic flux density that results for commercial devices to

$B = 0.008 \frac{T}{A} \cdot I$ where I is the electrical current through the coils. We show them as a

slider variable between 0 and 10 (ampere). That's pretty strong. Like the capacitor, the coils communicate to the magnetic field about the value and transparency. Like the electric field, the magnetic field consists of only one picture.

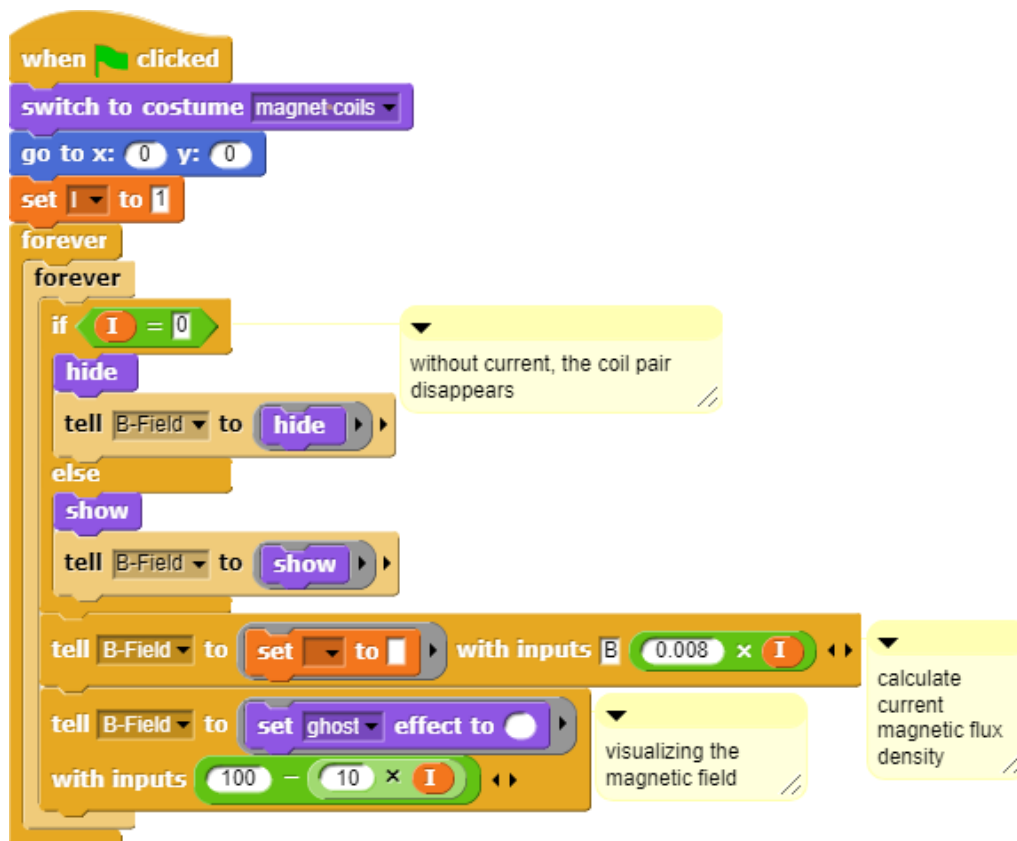

³⁰ You can really make it much more beautiful!

If we switch off the electrical field and look only at the electron path in the magnetic field, we get an almost circular path, but not a closed one. The spiral results by calculation inaccuracies, because the calculated changes are much too big. We'd have to calculate in much smaller steps. So, we still have to work on that!

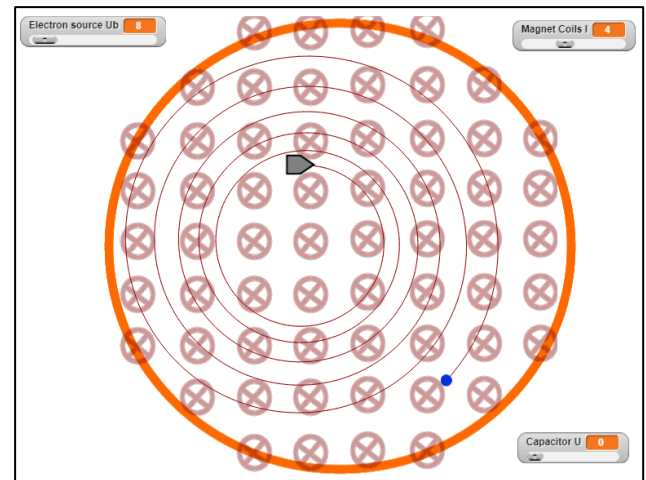

11.4 The Electrons

Now comes the bitter moment where we can no longer avoid physics. Be that as it may.



Two forces act on an electron in the arrangement: the electric and the magnetic. With the electric, it's pretty simple. It's upwards here because the electron has a negative charge:

$$F_{e,y} = e \cdot E$$

The Lorenz force $\vec{F}_L = q \cdot \vec{v} \times \vec{B}$ is perpendicular to the current velocity of the electron and the field direction. So, we have to work with vectors. The magnetic field has only one component in the z-direction, i.e. "into the screen", the speed only two components in the x- and y-direction "on the screen".

Therefore, the following applies:
$$\vec{F}_L = e \cdot \begin{pmatrix} v_x \\ v_y \\ 0 \end{pmatrix} \times \begin{pmatrix} 0 \\ 0 \\ B \end{pmatrix} = e \cdot \begin{pmatrix} v_y \cdot B \\ -v_x \cdot B \\ 0 \end{pmatrix}$$

Summarized:
$$\vec{F}_{gesamt} = e \cdot \begin{pmatrix} v_y \cdot B \\ E - v_x \cdot B \\ 0 \end{pmatrix}, \text{ and there is: } \vec{F} = m \cdot \vec{a}$$

we obtain for the accelerations in both directions:

$$a_x = \frac{e}{m} \cdot v_y \cdot B \quad \text{und} \quad a_y = \frac{e}{m} \cdot (E - v_x \cdot B)$$

with the signs corresponding to the coordinates of *Snap!*. These accelerations change the velocity components and these in turn change the position of the electron. That's it.

We can transfer these results directly into the electron's script. We adapt the constant e/m a little bit, because "real" electrons are significantly faster than our screen representatives. No other adjustments are required. The electron therefore only needs the "too large" local variables e/m and the acceleration and velocity components. In order to better follow the track, it is drawn on the stage.

```

when clicked
  set e/m to 1.76
  switch to costume electron
  go to x: 10 + x position of Electron-source y:
  y position of Electron-source
  forever
    clear
    pen down
    wait until Ub of Electron-source > 0
    set vy to 0
    set vx to sqrt of 2 * e/m * Ub of Electron-source
    repeat until
      touching edge ? or touching ? or key space pressed?
      if x position > -280 and x position < 280
        set ax to e/m * vy * B of B-Field
        set ay to e/m * E of E-Field - vx * B of B-Field
        change vx by ax
        change vy by ay
        go to x: x position + vx y: y position + vy
      hide
      go to x: 10 + x position of Electron-source y:
      y position of Electron-source
      show
  
```

here the correct value of 1.76×10^{11} C/kg has been changed in favour of a speed that can be displayed.

wait for it to start.

accelerate electrons with U_b

fly to the edge or to the capacitor plates

the electrical and magnetical forces act within the arrangement

back to the top

You can now observe the sometimes amazing movements of the particles. Of course, it has to be asked what is true and what can be attributed to numerical effects. Projects never end, they give impulses to further questions!

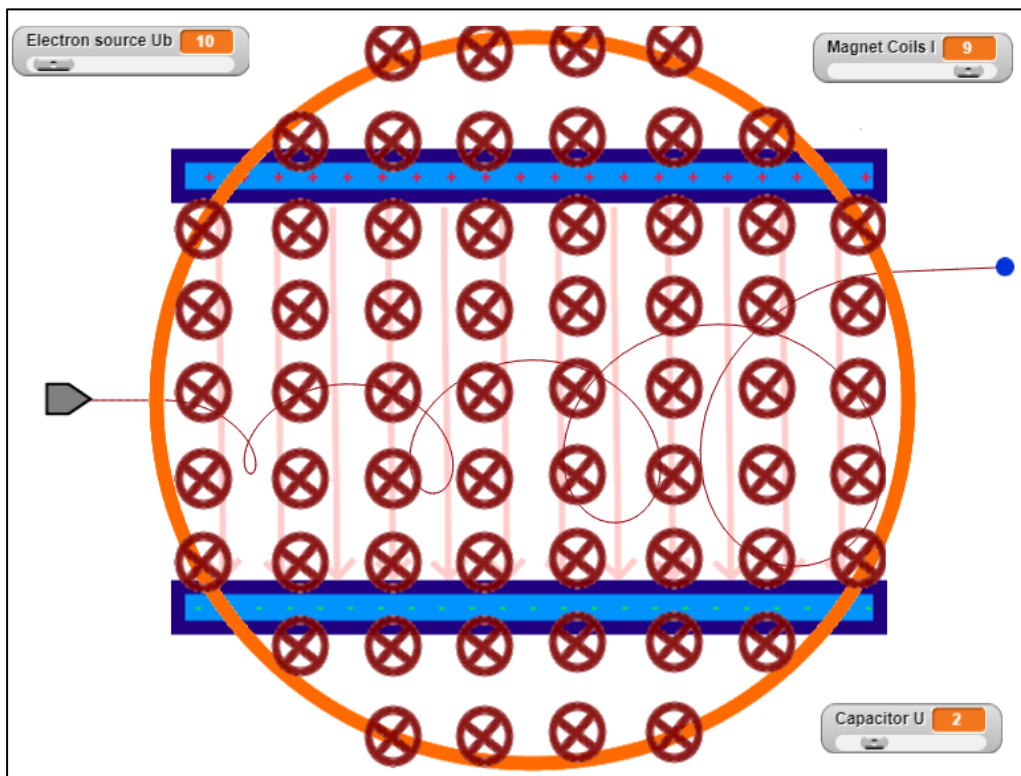

12 Texts and Related Topics

12.1 Operations on Strings

Contents:

1. use of the built-in string blocks
2. development of new string features
3. creating your own library

Like its predecessors, *Snap!* contains a set of methods, reduced to the essentials, that work with strings. This includes

- *join* $\langle string1 \rangle \langle string2 \rangle$: the concatenation operator for concatenating several strings. The result is a new string. The operator can be extended with additional arguments using the arrow keys.
- *split* $\langle string \rangle$ by $\langle char \rangle$: the operator for splitting a string into a list. The separations are made at the specified character, typically the blanks.
- *letter* $\langle n \rangle$ of $\langle string \rangle$: returns the n th character of a string.
- *length of* $\langle string \rangle$: returns the length of a string. (Not to be confused with *length of* $\langle list \rangle$!)
- *unicode of* $\langle char \rangle$: returns the unicode of a character.
- *unicode* $\langle n \rangle$ as *letter* : returns the n th Unicode character.

Other string operations can be found in the libraries *Tools* and *Words, Sentences*. They can be imported from the File menu. The new blocks are located below the *Make a block* button in the *Operators* palette. We want to go a different way here by building up some helpful methods from the basic operations. First, we want to write a method *rest of* $\langle text \rangle$ from $\langle index \rangle$ which returns the rest of a string from a certain index. So, we create a new block, which we assign to the operator palette this time, so that it looks nice green like the string operators. Since this is a function, we click on "Reporter" and because of course others should also benefit from our work, let's leave it at "for all sprites". As already described several times, we can insert the parameters at the +-characters between the words of the method header. We typify them as text or number and specify the default value 1 for the parameter index. Both are displayed in the method header as *index # = 1*.

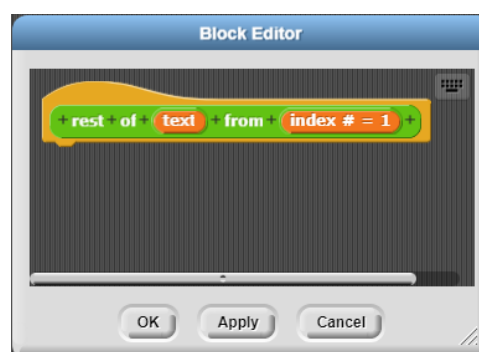

In the script we copy all characters of the text beginning with the index into a string variable *result*. This is returned as function result using the *report* block. To make things nice and fast, we'll pack it into a *warp* block.

```

+rest of+ text +from+ index # = 1 +
script variables i result
warp
set result to
if index > 0
set i to index
repeat until i > length of text
set result to join result letter i of text
change i by 1
report result

```

Similarly, the function *beginning of <text> to <index>* returns a string.

```

+beginning of+ text +to+ index # = 2 +
script variables i result
warp
set result to
set i to 1
repeat until i > index or i > length of text
set result to join result letter i of text
change i by 1
report result

```

Both functions make it easy to get a section of a string.

```

+part of+ text +from+ start # = 1 +to+ end # = 2 +
report rest of beginning of text to end from start

```

And the position of a substring in another string can also be determined - nicely recursively. If it does not exist, 0 is returned.

```

+index of+ part +in+ text +
script variables pos
warp
if length of text < length of part
report 0
else
if beginning of text to length of part = part
report 1
else
set pos to index of part in rest of text from 2
if pos = 0
report 0
else
report 1 + pos

```

This makes it easy to implement standard operations such as replacement in strings.

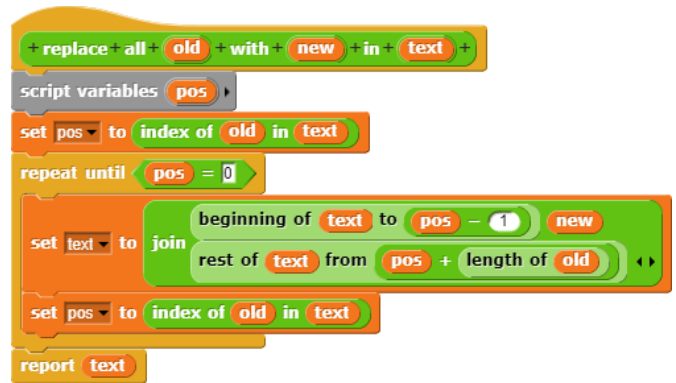

To make mankind happy with these new possibilities, we export the created blocks to a library. To do this, we select *Export blocks...* in the File menu and then select the blocks to be exported - all of course! We receive a file *string operation-blocks.xml*, which we save in a suitable place. If necessary, we can load the blocks into other projects via the file menu.

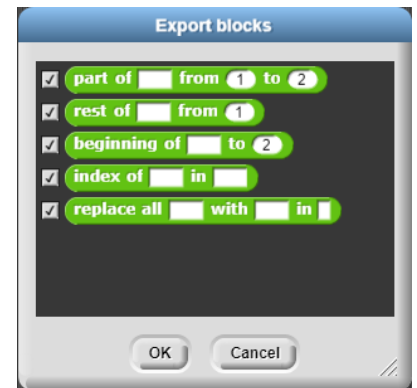

12.2 Vigenère Encryption

Contents:

- using the Tools library
- higher order functions
- additional control structures

Vigenère encryption is an extension of Caesar encryption, in which each character of plain text is shifted by a number in unicode resulting from a key character. Usually the key is shorter than the text to be encrypted, so you simply extend the key until it is at least as long as the plain text.

Beispiel:

plain text:	THISISASECRETTEXT
key:	NOKEY
extended key:	NOKEYNOKEYNOKEY

Thus, the first character of the plain text (T) is shifted by 14 characters (N is the 14th character), the second character (H) is shifted by 15, the third character (I) is shifted by 11, and so on. If you get characters larger than Z, the characters are moved cyclically starting at A - as is usual with Caesar encryption.

We write a little script that specifies the key and the plain text and lets a function determine the ciphertext.

So only the encryption method is of interest.



Since we work with the character codes, we need two blocks from the *Operators* palette.: *unicode of <char>* und *unicode <code> as letter*.

First of all, we want to be able to convert codes from lowercase (97 .. 122) to uppercase codes if necessary. Afterwards, we generate a list of character codes from the plain text, named *textcodes*. Creating a list from a string is easy when loading the *Tools* library.³¹ There we find the operation *word → list <string>*. Over this list we "map" a function that calculates a new list from the individual characters of the list. We pass the CODE of this function to the *map <function code> over <list>* - block, which can be recognized by the grey ring around the function block. This means that the function is not executed first, as usual, and then the result is transferred, but the program code of this function is passed to be executed in the *map-over*-block.

In this case, the "mapped" function consists of first determining the unicode of a character and then sending it through the *code in capitals* function.

We get the result we are looking for:

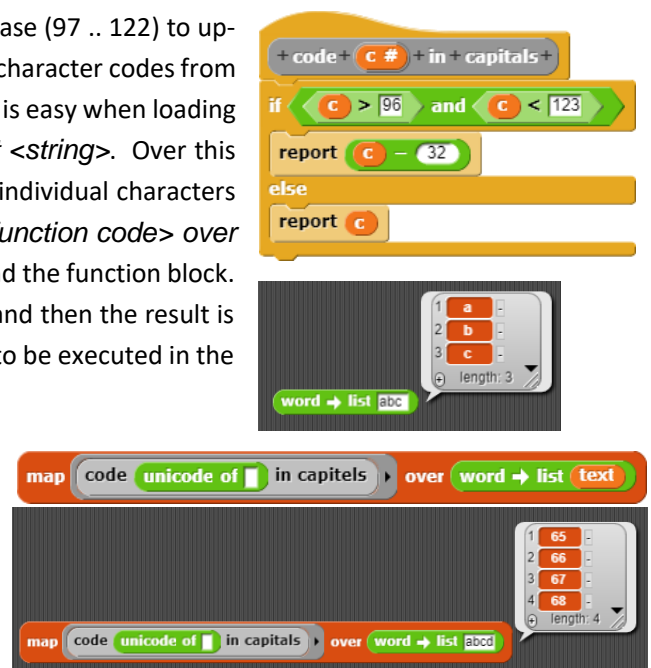

³¹ see Harvey, B. and Mönig, J.; Snap! 4.1 Reference Manual, <http://snap.berkeley.edu/snap-source/help/SnapManual.pdf>. You can find it by clicking on the Snap! icon in the top-left corner of the Snap! window.

We save the code-lists of plaintext and keys in the variables *textcodes* and *keycodes*.

Next, we extend the *keycode* list by the codes of the key until the list is at least as long as the *textcode* list. As help we use a variable *help* and a new control structure called *for each <item> of <liste>* from the *Tools* library.

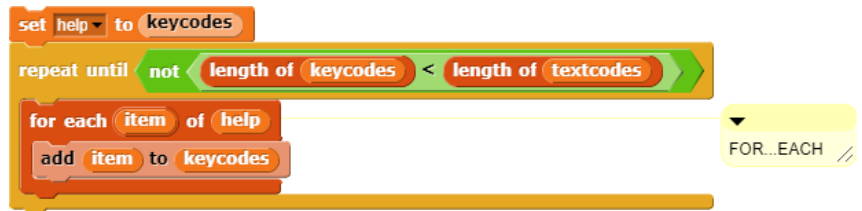

Now all we have to do is apply the Vigenère procedure, in this case only to the letters. Instead of mapping a function, this time we use the *For loop* from the *Tools* library:

for < counter> = <start> to <end>.

We use it to scroll through all characters in the *textcode* list and encrypt them as indicated. Note that there are two versions of the *length of* blocks: one for strings and one for lists.

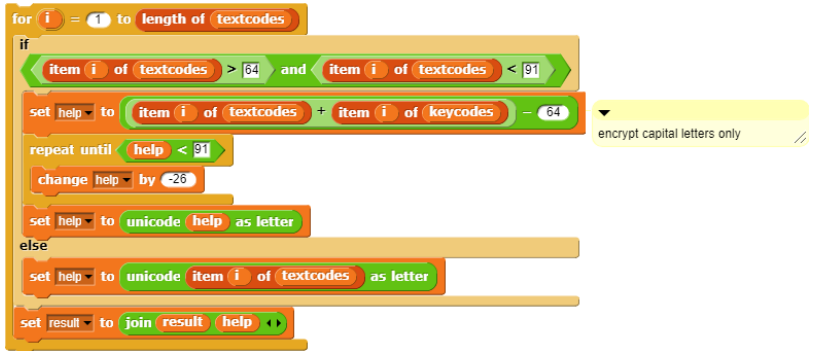

The process as a whole:

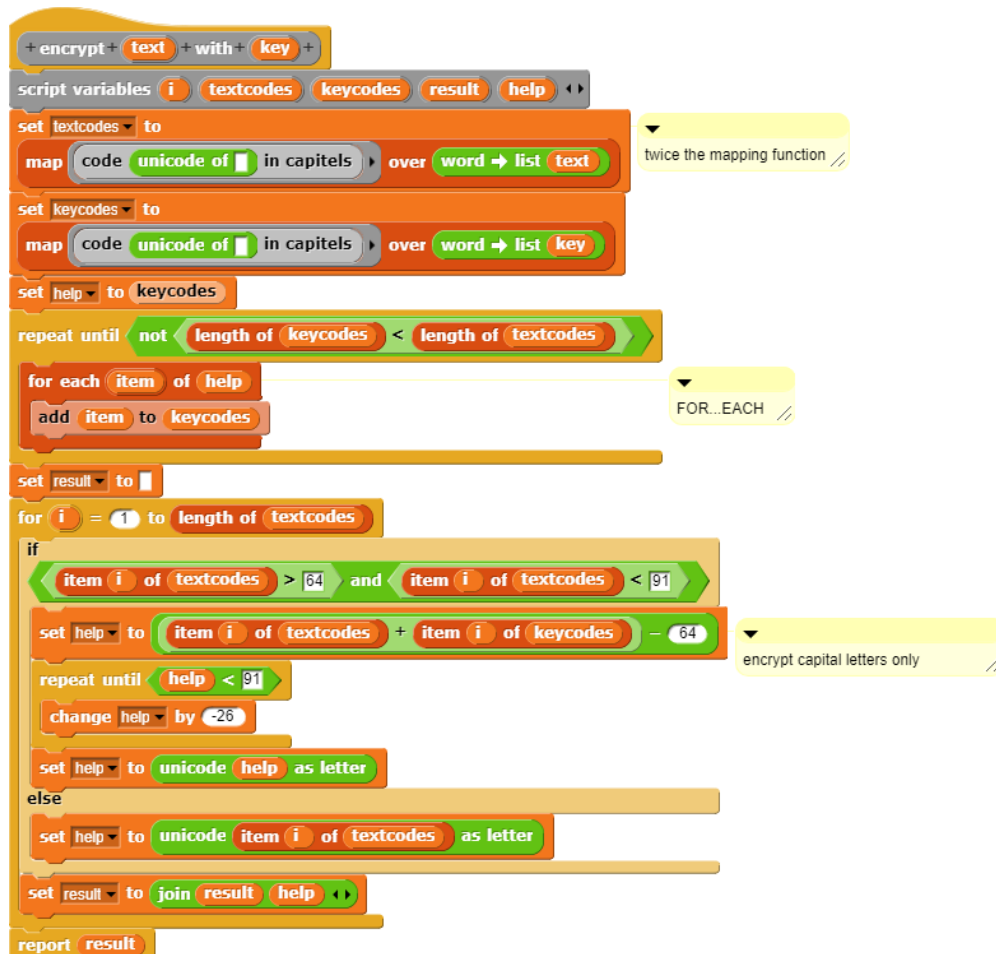

12.3 DNA-Sequencing³²

Contents:

- using your own string library
- working with strings and lists
- working top-down

In bioinformatics, subsequences are extracted from a broth of biomolecules containing fragments of DNA strands. The entire DNA strand is reassembled from these. Here we use a very simplified model, in which the sections are represented by strings consisting of the characters A, C, G and T. The fragments "overlap" partially, so that the original DNA can be reconstructed from matches at the chain ends.

First of all, we need DNA. Sequences can be found on the Internet. However, since the meaning of the sequence is not important here, we simply create it randomly.

The product of this method, a long character string, we now have to "break", i.e. divide it into pieces of different lengths, which partly overlap each other. We accomplish this task by adding a piece of the end of the predecessor to a section at the front. On the first section, this piece is empty. We use the string library we created in chapter 12.1.

full DNA CAAGGTAGCTATCTCCTAATGAGCCAAGTAACCTGGCTAAAAATCTGGCGTCTCGGCCTGAAGTTGAGTGAAAAACG

DNA reconstructed CAAGGTAGCTATCTCCTAATGAGCCAAGTAACCTGGCTAAAAATCTGGCGTCTCGGCCTGAAGTTGAGTGTA

DNA pieces

```

1 CCCATGACCTACAAAATCCCGTGGGTGACAGTGG
2 CATAAACTTGAGGCCTCGACAGCTGGTAAAGTAAGC
3 TGAGCCAAGTAACCTGGCTAAAAATCTGGCGTCTCGGCCTGTA
4 CAAGGTAGCTATCTCCTAATGAGCCAA
5 TCTGGACCATATCTTAAGATACTGGGACTTCTCT
6 AGTAAGCCAGATCAGTACGAGGCGAGTTAGCA
7 CTGTGTAAAGGCAACGTGGCTGGCGATGCCGCCAAACGAGGG
8 GAGCCTCGAAAATATAGAGCTGGTATTAACCTGTGGAAG
9 AAACGAGGGGTTAACCCCTCTGTAATTATGG
10 CCATCCGTCCTGACTGAATCTCTGGACC
11 CGGCCGTAAAGTTGAGTGAAAAACGAGCAGCCATAAA
12 ACAGTGGATCTGTACAAAGGCCGTGAGCCTC
13 GGCACCTCTAGTAACCACTGAGCAACTGAGAGACTCCCATCCGT
14 GTAGCTCCCTACCACCTTGGCTCCGTGAGACACCTTAATAT
15 CGAGTTAGCAAGGTTAGGATATTAATCATGAGCCTC
16 TTATGGGGGTACTCTGGCCGACAAATCCCATGACCT
17 CTTAATATAAGTCCAAGTGTACGCACTCC
                    
```

length: 17

connections

17	A	B
1	16	10
2	11	6
3	4	8
4	0	0
5	10	8
6	2	7
7	8	10
8	15	7
9	7	9
10	13	8
11	3	9
12	1	8
13	17	8
14	12	8
15	6	10
16	9	6
17	14	8

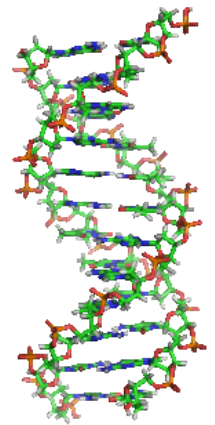

DNA-HELIX
(FROM [HTTPS://DE.WIKIPEDIA.ORG/WIKI/DESOXYRIBONUKLEINSÄURE](https://de.wikipedia.org/wiki/Desoxyribonukleinsäure))

```

+ produce + DNA + of + length + n # +
script variables result r
warp
set result to
repeat n
  set i to pick random 1 to 4
  if r = 1
    set result to join result A
  else
    if r = 2
      set result to join result T
    else
      if r = 3
        set result to join result C
      else
        set result to join result G
report result
                    
```

```

+ break + in + pieces + DNA + dna +
script variables result piece r
warp
set result to list
set piece to
repeat until length of dna < 25
  set i to 20 + pick random 1 to 20
  if r > length of dna
    set i to length of dna
  set piece to join piece beginning of dna to r
  set dna to rest of dna from r + 1
  add piece to result
  set piece to rest of piece from
    length of piece - 4 - pick random 1 to 5
  if length of dna > 5
    add dna to result
report result
                    
```

³² A short description can be found at http://molgen.biologie.uni-mainz.de/Downloads/PDFs/Genomforsch/Modul10B_Skript2015-Hankeln.pdf.

The sections are still in the correct order, so reconstruction would be no problem. We change that by confusing the order. With the following command sequence, we get the wanted "soup" from pieces of DNA.

```

set full DNA to produce DNA of length 500
set DNA pieces to break in pieces DNA full DNA
set DNA pieces to mix DNA pieces
    
```

In order to reconstruct the original DNA from this, we have to determine which fragments were once connected to each other. We create a list of *connections* in which we enter the predecessors and the length of the overlap. Since the first section has no predecessor, its overlap length is zero.

```

+ mix + list : +
script variables result r
set result to list
repeat until length of list = 0
  set i to pick random 1 to length of list
  add item r of list to result
  delete r of list
report result
    
```

```

+ find + connections +
script variables i
warp
set connections to list
set i to 1
repeat until i > length of DNA pieces
  add who is the predecessor of item i of DNA pieces ? to connections
  change i by 1
    
```

One piece of DNA "hung" on another, if a sufficiently long overlap can be found. Since similarities can also be random, we define "sufficiently long" as "5". For

connections		
	A	B
17	A	B
1	16	10
2	11	6
3	4	8
4	0	0
5	10	8
6	2	7
7	8	10
8	15	7
9	7	9
10	13	8
11	3	9
12	1	8
13	17	8
14	12	8
15	6	10
16	9	6
17	14	8

a given sequence, there are four ways to "guess" the correct character for each character. The probability of generating the character randomly is 0.25. With five characters, it is then $0.25^5 = 0.00098$, which is enough "improbable" for us.

The only remaining problem is to determine whether and how far two DNA sequences overlap. We put it (mentally) one above the other from the middle of the first and then move the second step by step "to the right" until we find either an overlap or are too close to the end. Ready.

```

+ how far + overlap + end + with + start + ? +
script variables i hit?
warp
set hit? to false
set i to round length of start / 2
if i > length of end
  set i to length of end
repeat until hit? or i < 5
  set hit? to beginning of end to i = rest of start from length of start - i + 1
  change i by -1
if hit?
  report i + 1
else
  report 0
    
```

```

+ who is the + predecessor of + a + ? +
script variables i overlapping
warp
set overlapping to 0
set i to 1
repeat until i > length of DNA pieces or overlapping > 4
  if not item i of DNA pieces = a
    set overlapping to how far overlap a with item i of DNA pieces ?
    change i by 1
if overlapping > 4
  report list i - 1 overlapping
else
  report list 0 0
    
```

12.4 Text Files and Frequency Analysis

Contents:

- store data on your own computer
- store data on a server
- table views

From dubious sources we got the information that there is an unbelievable secret (probably German) text in the file *ciphertext.txt* on our computer. We even know which directory it is in. To be able to edit the text from *Snap!*, we create a variable *ciphertext* and display it in the workspace. The content is zero. We select from the context menu of the displayed variables the point *import...*, navigate to the named directory and select the secret text. It appears in the variable.

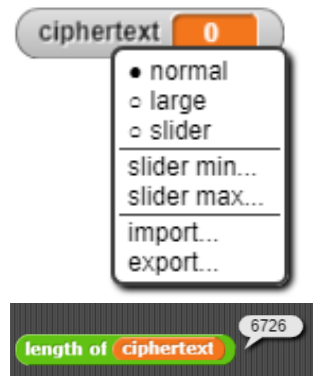

To be on the safe side, we want to save the text in another place immediately. We select the point *export...* from the same context menu and get the file *ciphertext.txt* at the bottom-left of the window, similar to saving a project. We find it in the download directory of our computer. The described procedure is simple but cannot be controlled by the program. It has to be done "by hand".

Text files are a simple but reliable tool for exchanging data between different computers. In order to do this, we need an *http server* (which may also be the same computer) running a script with the desired functionality - here: loading and saving text files.

Attention: There is a problem: If we use a server with HTTPS connection (such as the Berkeley Snap Server), we cannot access an external HTTP server. The browser prevents this. So, if the given scripts do not work for you, please save *Snap!* completely on your computer (your browser can do this) and start *Snap!* locally from your computer. The scripts will work then.

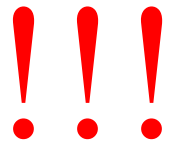

In this case we want to select the server *snapextensions.uni-goettingen.de* on which the script *handleTextfile.php* is located. We draw two costumes for a *text server* sprite that indicate whether or not we are connected to the server. The data exchange with the server should be logged in a variable *infobox*. By clicking the green flag, our variables should be initialized, whereby the *connection* gets a rather cryptic value. This consists of the server address, a login script and some variables – just PHP. We change our *infobox* to "table view" using the context menu, which looks a bit better. The output window then is like this:

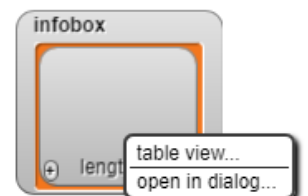
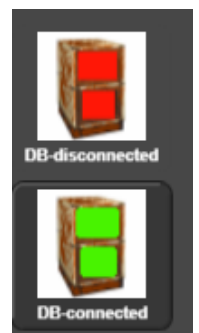
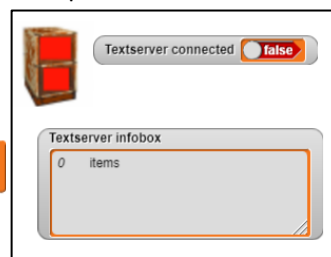
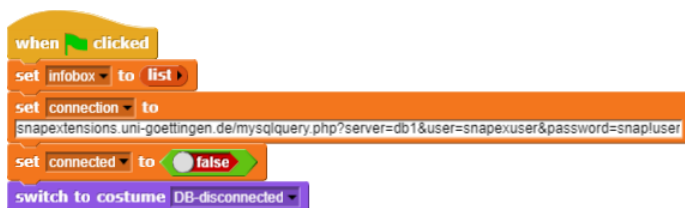

We need a connection to the server. This is done using the *url* block to which we pass the required data. We record success or failure in the *info box*.

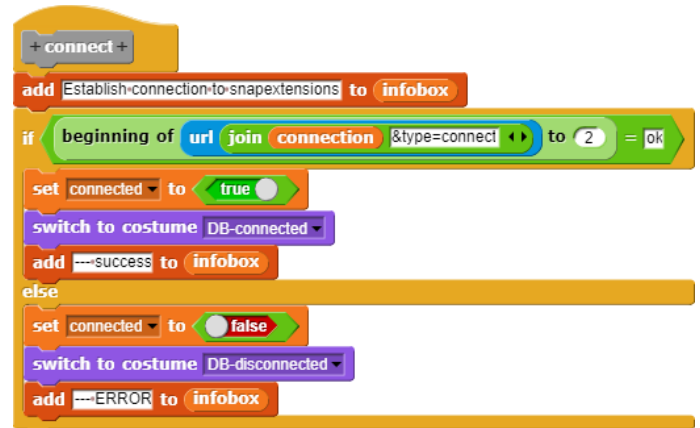

After executing this block, the connection to the server is established, but the text in our *info box* is only partially visible. Therefore, we click with the left mouse button on the column header *items* and drag the column to a width that all text is readable.

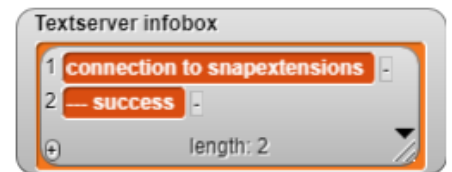

We want to write data to a file on the server. The text to be written and the file name are given as parameters. First we attach the extension ".txt" to the file name and make sure that the file is stored in the subdirectory *textfiles* on the server. Then, the *url* block transmits the required data.

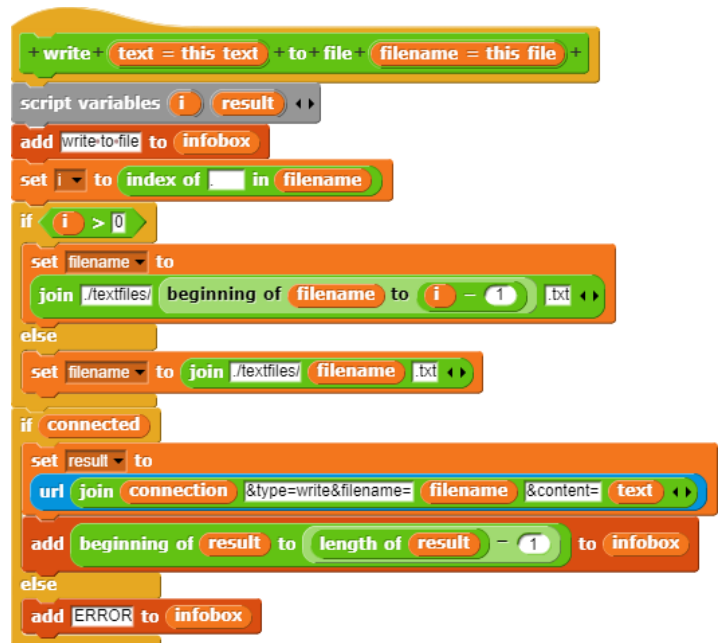

Reading from a file takes place accordingly.



We export the *text server* sprite into an XML file and can use its functionality in other projects.

After establishing a connection, writing and reading, our workspace looks like this :

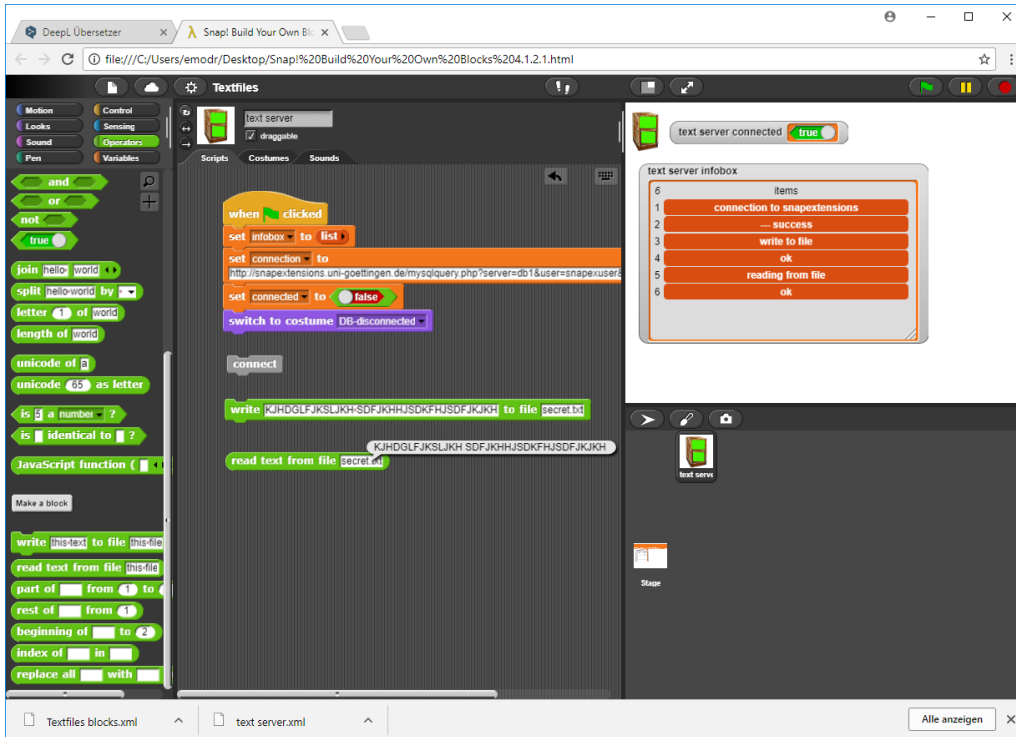

It doesn't help, we have to decode the cipher now. For this purpose, we perform a frequency analysis - i.e. we count how often the individual letters appear in a text.

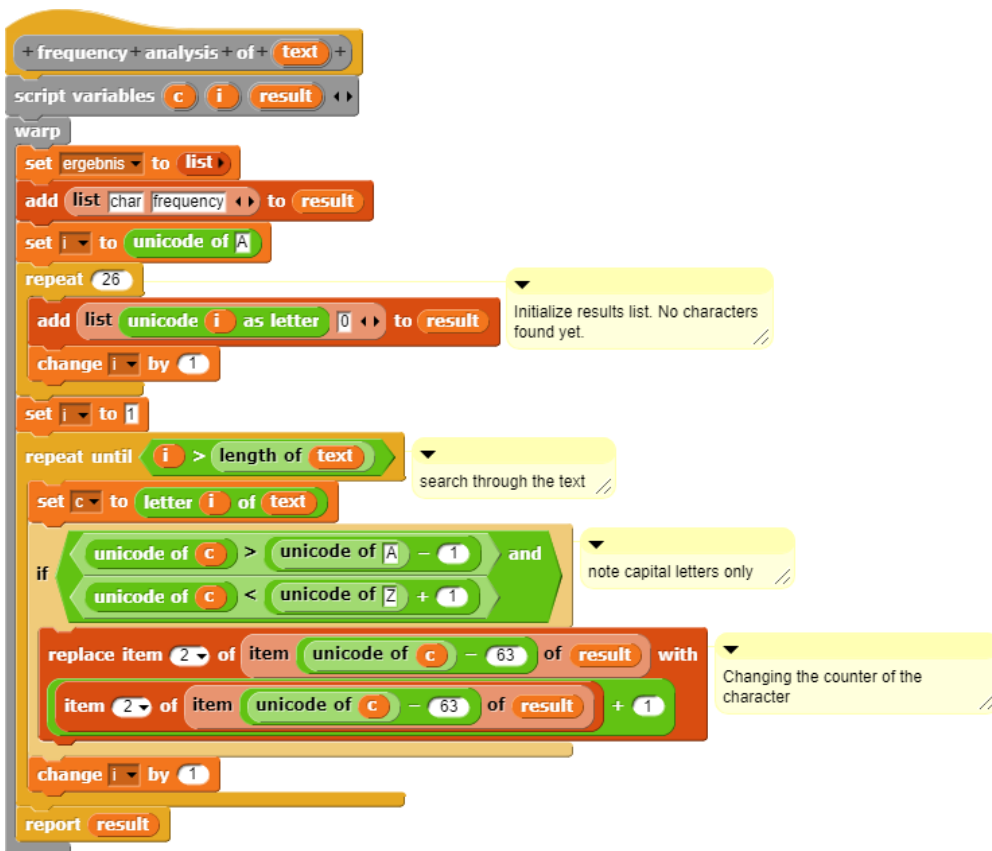

Table view		
	A	B
27		
1	char	frequency
2	A	94
3	B	159
4	C	46
5	D	40
6	E	433
7	F	248
8	G	570
9	H	4
10	I	380
11	J	51
12	K	182
13	L	290
14	M	283
15	N	113
16	O	364
17	P	2
18	Q	269
19	R	214
20	S	151
21	T	1034
22	U	62
23	V	131
24	W	2
25	X	303
26	Y	12
27	Z	79

Since E is the most common letter in German and it would be cruel (for me) if the text had been written in a different language, we save the list of frequencies in a variable *frequencies* and replace the large T in the ciphertext with a small e - because T is the most common one.

```
set frequencies to frequency analysis of ciphertext
set ciphertext to replace all T with e in ciphertext
```

Replacements were made with the usual loop:

```
+ replace + all + old + with + new + in + text +
script variables i result
warp
set result to
set i to 1
repeat until i > length of text
  if unicode of letter i of text = unicode of old
    set result to join result new
  else
    set result to join result letter i of text
  change i by 1
report result
```

Because the result is not too impressive, we need more replacements. We take G for n and perform this replacement.

```
set ciphertext to replace all G with n in ciphertext
```

We can analyze the ciphertext quite well if we divide it into lines with `split ciphertext by`

```
1 QeELeO ZFBMI /YSMXnn ASKZRxnR USn RSeLMe
2 eEn NeORUXRXNFnQen-RelDOXeBM VEL_eEneV VeMOZXBMen eFOSDXeEIBMen REDZeKILFeOVeO
3 MeOO ILXXLIVENeILeO USn RSeLMe, lEe MXNen KXnRYXeMOERe NeORILeEReOEIBMe eOZXMOFnRen.
4 YX, EBM MXNe QeE ZFOCX, Qen RSLLMXOQ NellEeRen! QeEeO eOMXNenen, FnUeORKeEBMKEBMen nXLFOJenen AeOQen EVVeO USO VeEneV ReEILe lLeMen.
5 RXN el nSBM XnQeOe IBMAeJeo REDZeK, QeE EV UeOKXfZ EMOeO QOeE OeElen En QXI KXnQ QeO eEQRenSilen USn EMnen NeJAFnRen AFOQen? EBM QenCe Q
```

For example, we find words like eEn . We therefore consider the E to be an i .

That was a good idea! Let's keep searching and trying replacements, and at some point, we'll find the secret! You just must hold out - there are only 23 letters left!

```
2 eEn NeORUXRXNFnQen-R
3 MeOO ILXXLIVENeILeO
```

12.5 SQL Databases

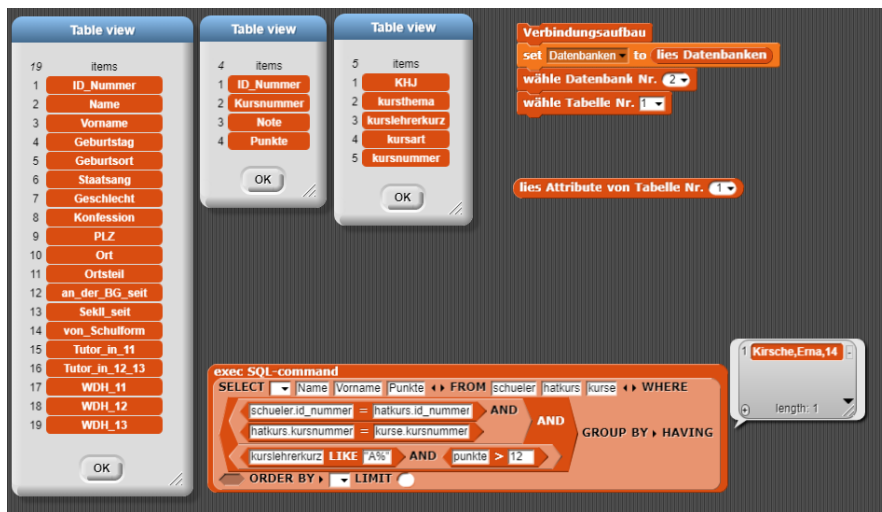

Contents:

- access to external databases
- SQL results and tables
- parameters with selection boxes

An important application of IT systems is access to external data sources. On the one hand, the Internet is available, on the other hand, the use of SQL databases is common. Since the use of this type of application is somewhat complicated in many computer languages, it is often handled separately from the algorithms. This makes this part of computer science quite boring: you either create ER diagrams on paper or query databases with special client applications, e.g. *PHPmyAdmin*, but do not use the results any further. With the help of *Snap!* this can be done differently!

We need a server that runs either on another computer or on our own, and on which - in this case - except to an http server and an SQL server there is a PHP script called *mysqlquery.php*. We send data required for an SQL query to the SQL server using the parameters *type, query, command, ...* The result of the query is either an error message or a table with results. If necessary, the script prepares it to be displayed as a list by *Snap!*. The source code of this script can be found e.g. on <http://snapextensions.uni-goettingen.de>.

We create a sprite called *SQLserver*, which shows by its costume whether there is a connection to the database or not. Some attributes such as *connection, connected, current table*, etc. store the current state, and the processes are logged in an *infobox*. This sprite is saved as *SQLserver* and can be loaded if required. The new blocks required for SQL queries are globally so that they are easily accessible for queries outside the server sprite. They are stored in the *SQLblocks.xml* file and must also be loaded.



First of all, we need access to the external SQL server. For this purpose, we set up a connection setup block. The local attributes are initialized, and the connection data is stored in the variable *connection*, so that it does not have to be entered each time. Then the connection is established, and the success or failure is noted in the variable *connected*.

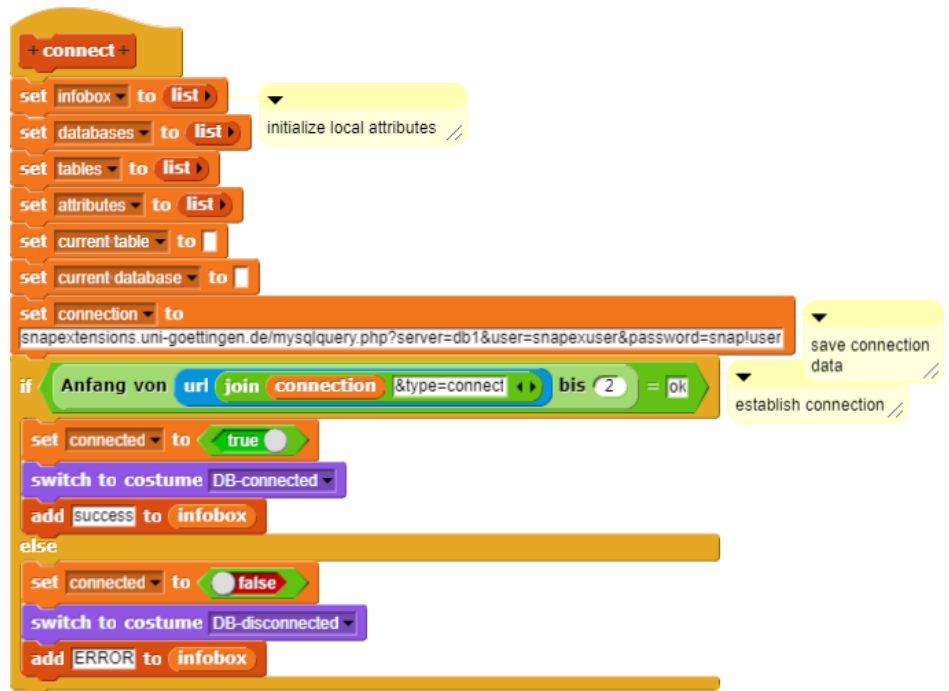

With the help of the reporter block *read databases*, the SQL server is asked for the existing databases. These are returned as a list. For the actual query, the value "getDBs" has to be appended to the connection data as "type".

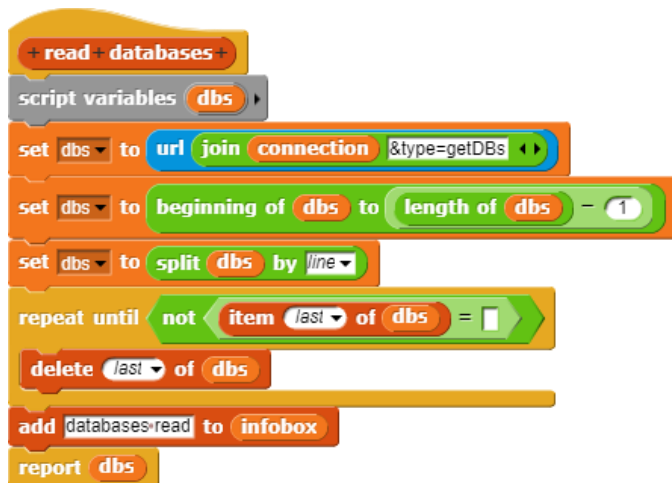

The connection setup and the selection of a database can be saved as a block sequence.



The last block selects the specified database. Of interest is the small arrow next to the parameter 3. If you click on it, a selection list with the possible values appears.

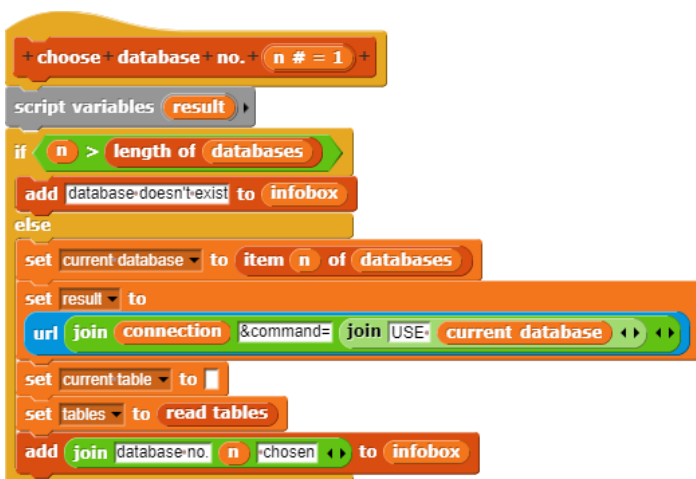

A selection list can be created in the block editor by right-clicking in the dark area. You get a small context menu with the item *options...* In the pop-up window *Input Slot Options* the possible input options are entered.

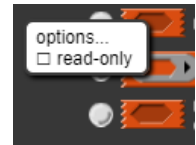

In a very similar way, the system determines which tables are contained in the selected database and in which attributes the tables are structured.

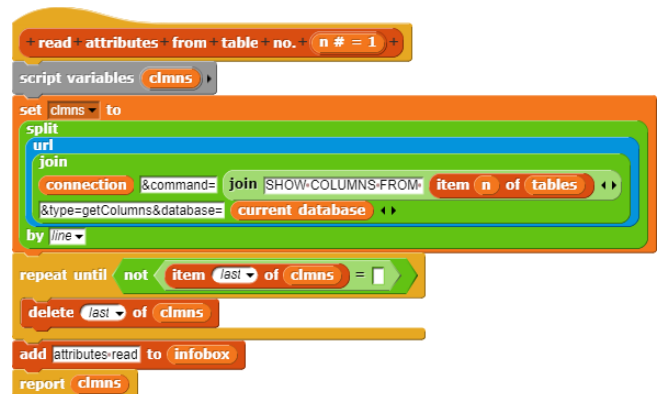
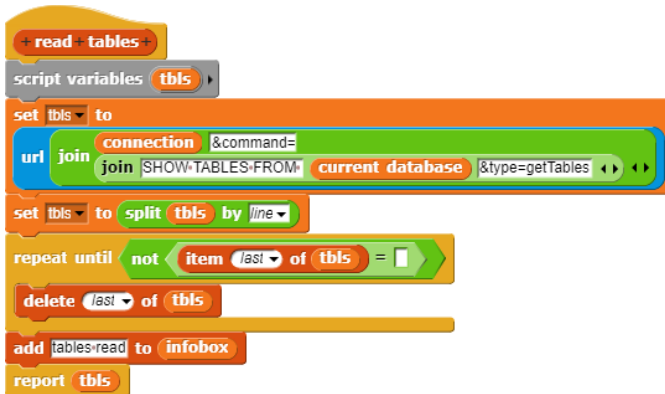

With the help of the new blocks we can find out which tables are available and which attributes they contain. In the context menu of the list received, the result can be displayed permanently using the "open in dialog" option. In this way, the values required for requests can be clearly arranged on the screen.



We have now created the conditions for submitting queries to the database. For this we need SQL aggregate functions and operators. Using the data from the table views and two types of SELECT blocks, these can be used to interactively compile SQL queries.

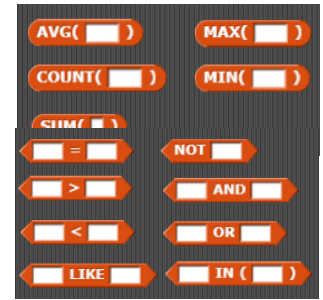

Please note that only the texts of the queries are generated! The requests are not (yet) executed.



These blocks can now be used to create and control SELECT requests.

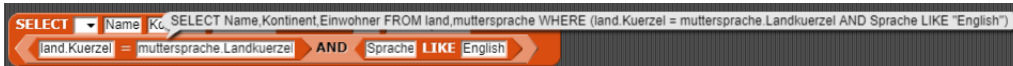

For the execution of such queries we have a - last - block available. An SQL command is passed to it either as text or as a result of a SELECT block. Any empty entries in the reply list are deleted.

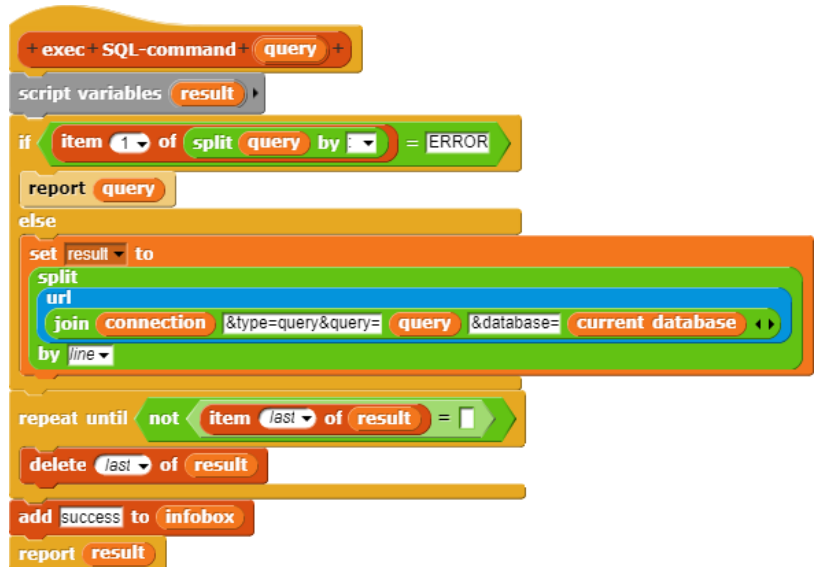

The simple SELECT block builds an SQL query from the parameters. It uses a reporter *list* → *string*.

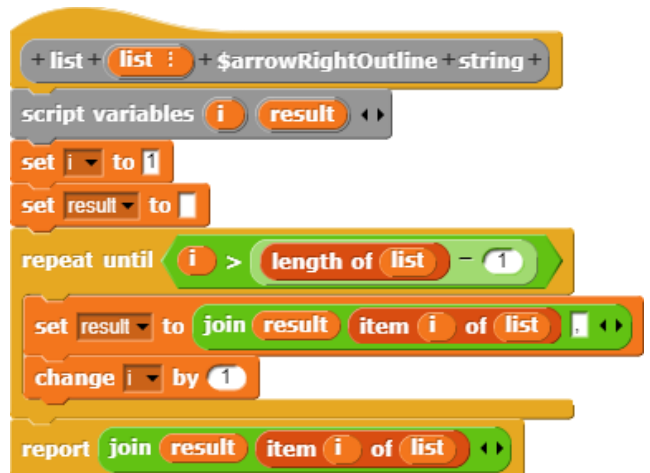

With a full SELECT block, this is no more complicated - only longer.

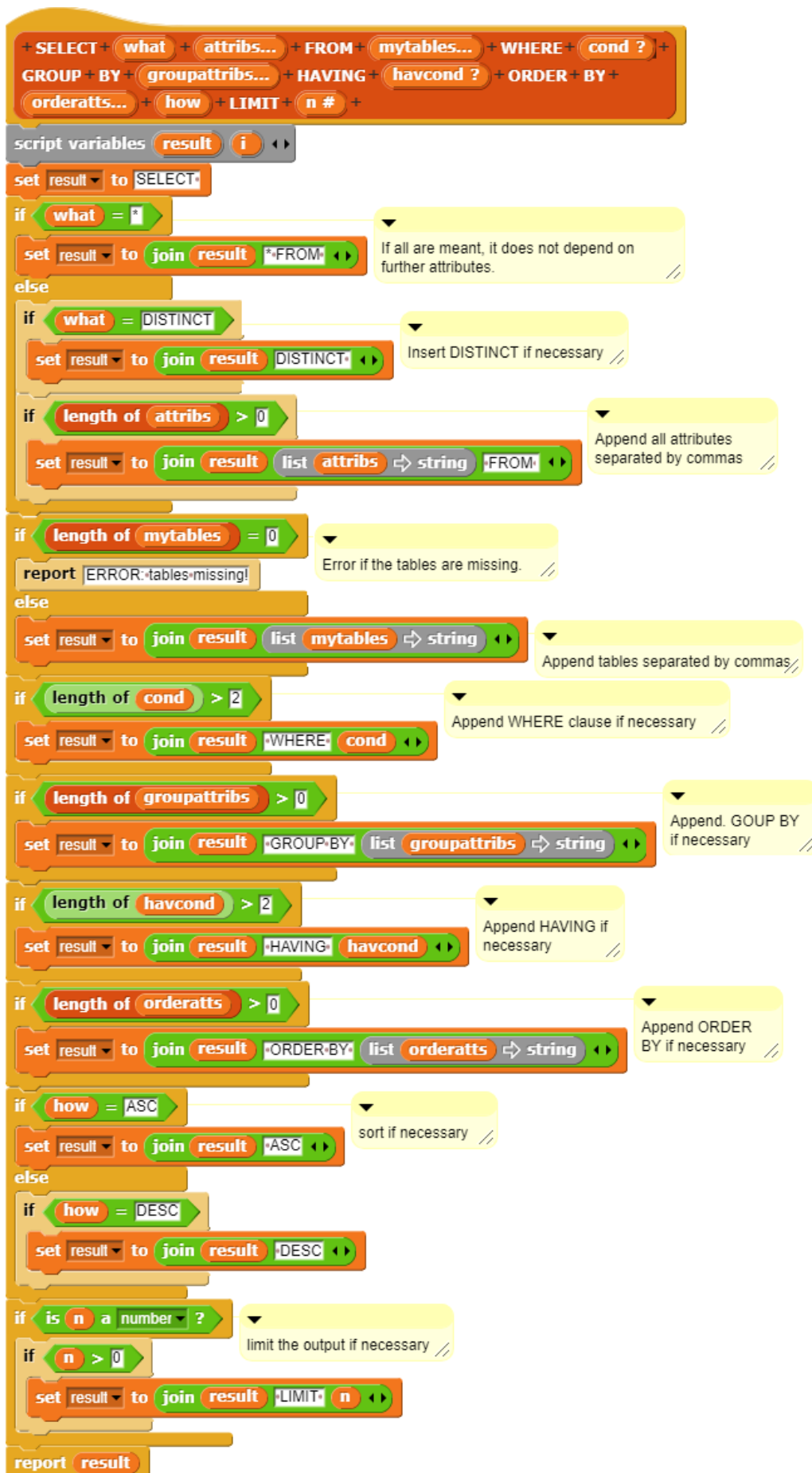

We can work with it now.

```

set answer to
exec SQL-command
SELECT Name, Kontinent, Einwohner FROM land, muttersprache WHERE
land.Kuerzel = muttersprache.Landkuerzel AND
muttersprache.Sprache LIKE "English"
    
```



answer

1	Aruba,North America,103000
2	Anguilla,North America,8000
3	Netherlands Antilles,North America,217000
4	American Samoa,Oceania,68000
5	Antigua and Barbuda,North America,68000
6	Australia,Oceania,18886000
7	Bahrain,Asia,617000
8	Belize,North America,241000
9	Bermuda,North America,65000
10	Barbados,North America,270000
11	Brunei,Asia,328000
12	Canada,North America,31147000
13	Cocos (Keeling) Islands,Oceania,600
14	Cook Islands,Oceania,20000
15	Christmas Island,Oceania,2500

length: 60

And it can also be more complicated: How many people speak which language?

```

set answer to
exec SQL-command
SELECT Sprache, SUM(Einwohner) FROM land, muttersprache WHERE
land.Kuerzel = muttersprache.Landkuerzel GROUP BY Sprache HAVING
ORDER BY DESC LIMIT
    
```

Amazing!

answer

457	items
231	Luo,30080000
232	Luri,67702000
233	Luvale,12878000
234	Luxembourgish,435700
235	Macedonian,24256100
236	Madura,212107000
237	Maguindanao,75967000
238	Mahor,149000
239	Maithili,23930000
240	Maka,15085000
241	Makonde,33517000
242	Makua,19680000
243	Malagasy,16790000

The resulting SQL library is intended to test SQL commands interactively and then - if successful - integrate them into new blocks that allow the database to be used without SQL knowledge. We clarify this with a simple request.

For a new project we first import the *SQLblocks* library, then the *SQLserver* sprite. In addition, we create an SQL user sprite. This asks the SQLserver to establish a connection.

```

tell SQLserver to
connect
set databases to read databases
choose database no. 2
    
```

Afterwards, query blocks can be created, which, for example, determine the data that are important for school statistics.

```

+ask+schueler+for+ criterion +
report
exec SQL-command
SELECT criterion, COUNT(criterion) FROM schueler WHERE
GROUP BY criterion HAVING
ORDER BY LIMIT
    
```

From another sprite, this method can be used without knowledge of database queries.

```

+studenty+by+ criterion +
report ask SQLserver for ask schueler for with inputs criterion
    
```

students by Geschlecht

1	m,44
2	w,68

length: 2

12.6 Tasks

1. A simple form of **block encryption** is to insert the text to be encrypted into a table with several columns from left to right and from top to bottom. If the last line is not filled, then any letters are inserted. The encrypted text is obtained by reading the table from top to bottom and from left to right.

Example:

```

DIESE      →      DRIHIHITSECEEETIHISXUMGMETNLEX
RTEXT
ISTUN
HEIML
ICHGE
HEIMX

```

What is the key? Implement the procedure.

2. **Eliza** is a well-known program that simulates a psychotherapist. He answers randomly to statements of the patient by either asking "typical" questions ("What would your mother say?") or taking these from parts of the patient's sentences ("What did you mean when they say: ...").

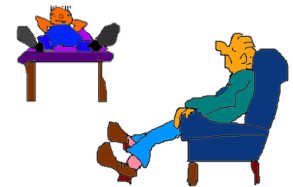

- a: Find out more about the project.
 - b: Realize the project.
3. **Genetic algorithms** simulate the evolutionary approach of nature by randomly generating new candidates to solve a problem. In this case, **palindromes** are sought, i.e. words that are read forwards and backwards are the same. The procedure consists of an initialization in which a random initial population is generated. In this case, a lot of random words. Afterwards a loop is run again and again, in which candidates for a recombination of individuals are selected based on a fitness function. At least one new candidate is created from two candidates. After that, random changes (mutations) occur. In the resulting new generation, the "best" candidates for the next round are selected on the basis of the fitness function (selection).
 4. The determination of the **Levenshtein distance** between two strings is used to determine the "degree of relationship" of the strings. Typically, these are DNA strands from the characters A, C, G and T.
 - a: Find out more about the process.
 - b: Implement the procedure.

13 Computer Algebra: Functional Programming

Contents:

1. advanced string operations
2. writing JavaScript functions
3. predicates and top-down-development

13.1 Function Terms

We want to show the possibilities of blocks by means of a small "computer algebra system". To do this, we have to define what functional terms are.

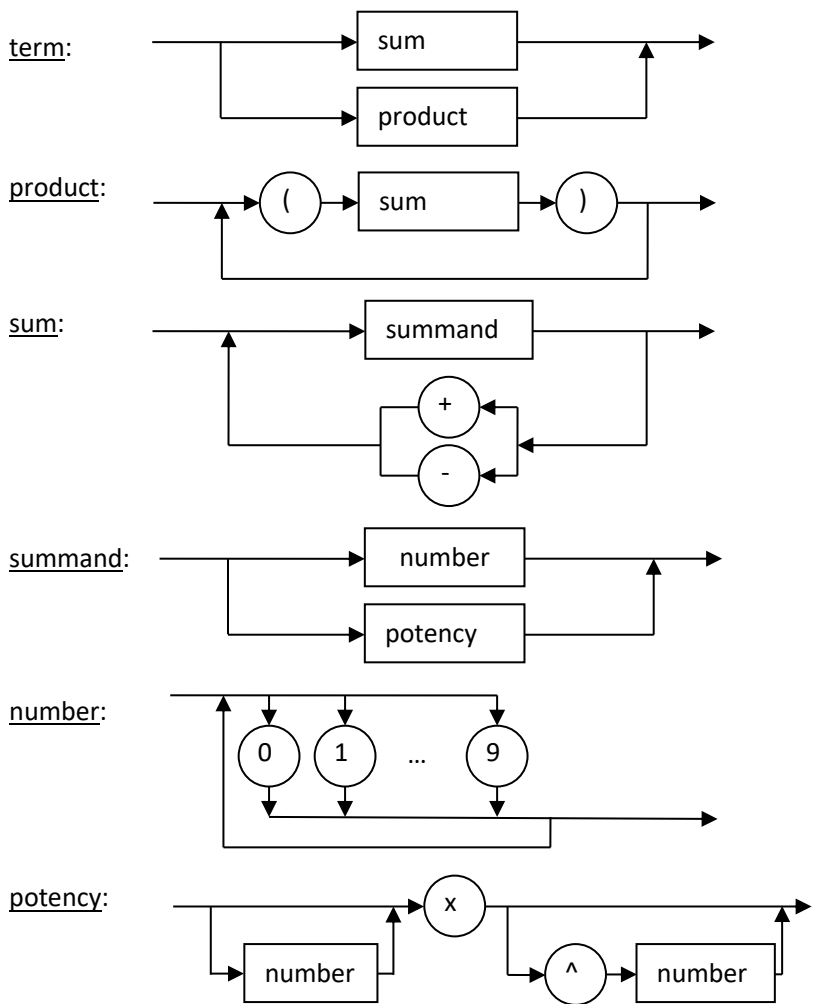

syntax diagrams

Function terms are e.g.: 3 $4x$ $(2x-1)(x^2+2)$ $(x)(x^2)(1-2x^4)$

13.2 Parsing of Function Terms

To work with function terms, of course, we need someone who understands them. We draw *Paul*, the little mathematician, and then we make him clever. First of all, Paul must be able to read function terms. To do this, he asks the user for a corresponding entry using the block *ask <question> and wait* from the *Sensing* palette. We shift the whole thing into Paul's method, which we define as a function. So, we select the oval block shape in the block editor. If we have defined a variable, e.g. *term*, we can assign the result of the input to it.

Next, we check whether the entry is correct. We move the corresponding methods to a sprite called *Parser*. In this we want to program functionally on the one hand and solve the problem on the top-down way of proceeding.

We create the locale block (*for this sprite only*) for the *Parser is <term> a correct term?* as a predicate, which can only return *true* or *false* as results. After that we have a nice title, but unfortunately still no content. Nevertheless, we can already use the block in scripts - just like other blocks. This allows recursive operations and is suitable for top-down development. Paul can ask the *Parser*, for example:



Since, according to the syntax diagrams, correct terms are either sums or products, we move the problem there by creating two corresponding predicates - still empty ones - locally (*for this sprite only*), because the rest of the problem doesn't concern external observers anymore.

Snap! evaluates logical expressions completely, which is nice when side effects have to be considered. However, this increases the runtime of tree-like call structures enormously. Therefore, we first write two predicates for the *lazy evaluation* of Boolean expressions: the second expression is only evaluated if the first does not already determine the result. As identifiers we choose the operators *&&* (*lazy and*) and *||* (*lazy or*), which are often used in programming languages.

The predicate *is <term> a correct term?* can now be specified completely.

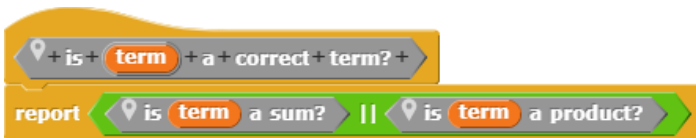

We continue this procedure for all elements of the language definition of correct function terms. First, we'll take care of the sum. This consists of either a single summand or a summand, followed by the correct operator (+/-) and a sum. We can write this directly if we still have an empty predicate *is <term> a summand?*

We have to be careful that our terms - strings - are not accidentally interpreted as numbers. For this reason, we have always set the type of input parameters *term* to "Text". If we forget this, the character string "123", for example, could be interpreted as the number 123. For example, the second element of the string is a 2, but there is no second element in the number 123. A corresponding access would lead to an error.



Paul, the mathematician

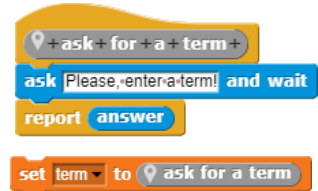

functional and top-down programming

top-down design with empty methods

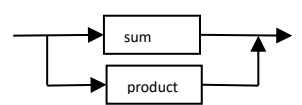

lazy evaluation

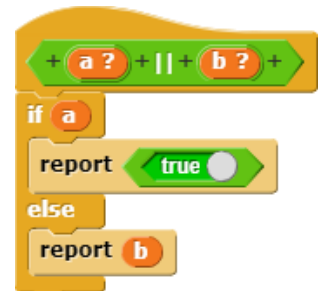
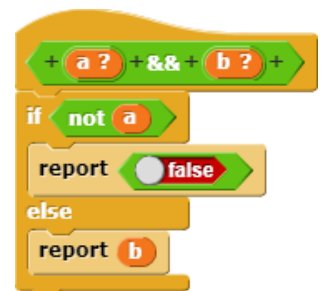

Pay attention to the type of parameters!

We need something else. The entered term is no longer examined in its entirety, but we must split it into two parts: the *beginning of <term> to <character>* and the *rest of <term> from <character>*. In addition, the position of a character in a character string is determined: *index of <character> in <term>*. In this case, we want to implement them as JavaScript methods, because time matters.

String processing with JavaScript functions.

+ beginning of term to char +

report

```

call
JavaScript function ( term zeichen ) {
term = term.toString();
zeichen = zeichen.toString();
if(term.length==0) return "";
else
if(term.indexOf(zeichen)==0) return "";
else return term.substring(0,term.indexOf(zeichen));
}
with inputs term char
                    
```

+ rest of term from char +

report

```

call
JavaScript function ( term zeichen ) {
term = term.toString();
zeichen = zeichen.toString();
if(term.length==0) return "";
else
if(term.indexOf(zeichen)==0) return term.substring(1,term.length);
else if(term.indexOf(zeichen)>=0) return term.substring(term.indexOf(zeichen)+1,term.length);
else return "";
}
with inputs term char
                    
```

+ index of char in term +

report

```

call
JavaScript function ( term zeichen ) {
term = term.toString();
zeichen = zeichen.toString();
if(term.length==0) return 0;
else
if(term.indexOf(zeichen)<0) return 0;
else return term.indexOf(zeichen)+1;
}
with inputs term char
                    
```

So, we write the predicates *is <term> a summand?* and *is <term> a sum?* each with an additional security prompt.

+ is term a summand? +

if length of term = 0

report false

else

```

report
  is term an addend? ||
  is beginning of term to an addend? &&
  is rest of term from a sum? ||
  is beginning of term to an addend? &&
  is rest of term from a sum?
                    
```

+ is term a summand? +

if length of term = 0

report false

else

```

report
  is term a number? || is term a potency?
                    
```

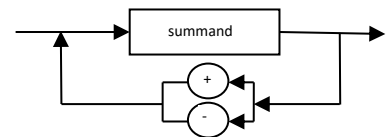

We are coming to the end. *is <term> a number?* is very easy to write when we have *is <term> a cipher?*

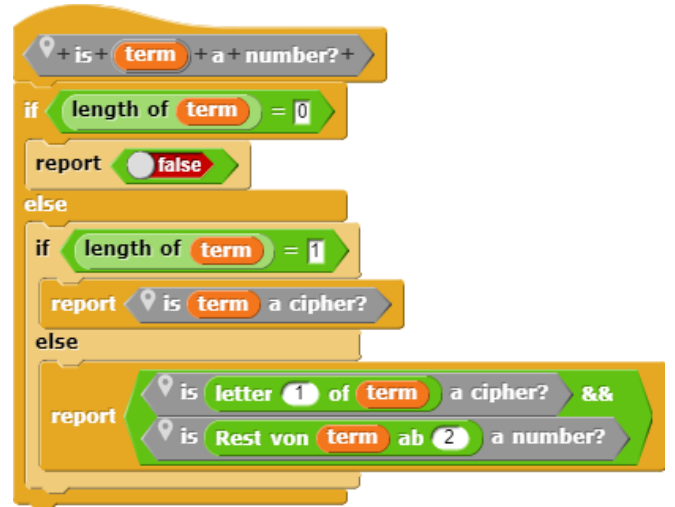

And how do you check a potency? That's also in the syntax diagram - we just have to copy all the details.

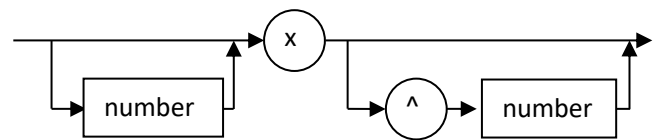
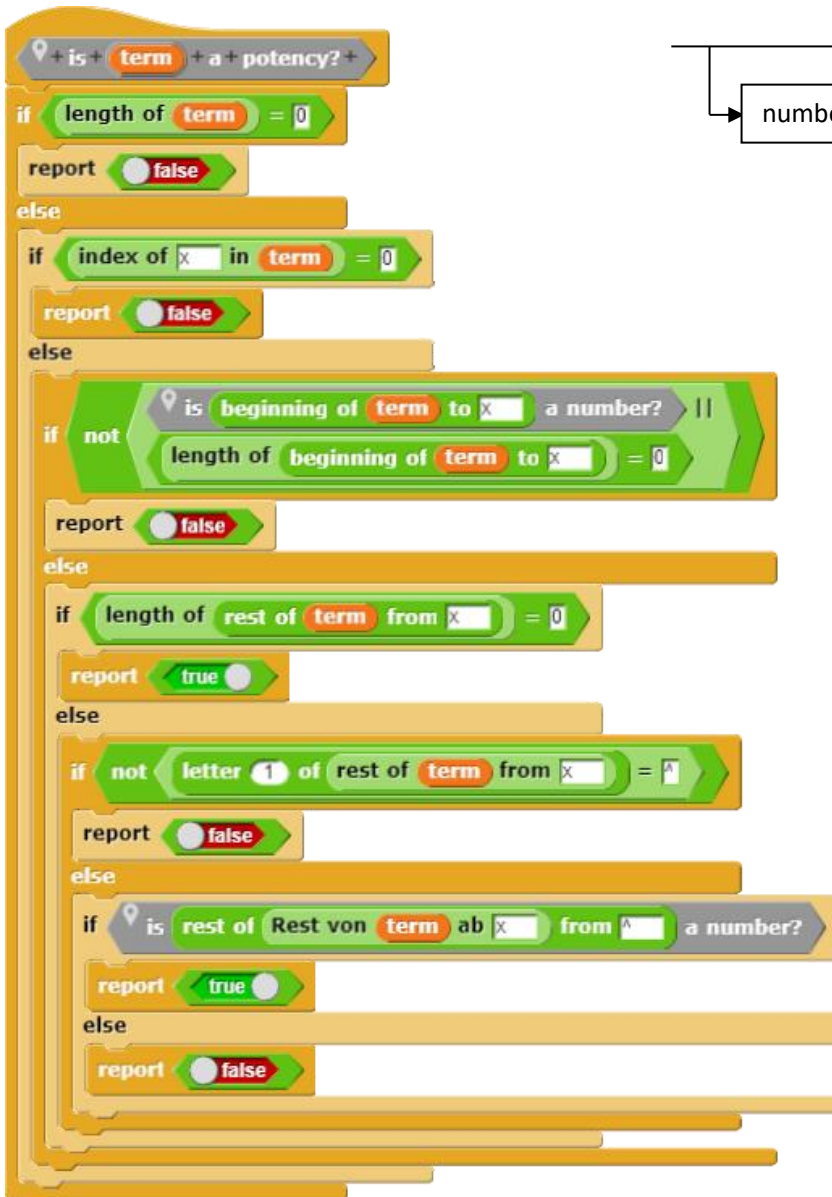

Now only the product is missing, which can be formulated in direct analogy to the sum, because a product consists (with us) of either a compounded sum or a sum followed by a product.

```

+ is+ term + a+ product?+
if length of term < 3
  report false
else
  report
    letter 1 of term = ( &&
    is beginning of rest of term from [ ] to [ ] a sum? &&
    letter length of term of term = [ ]
    length of rest of term from [ ] = 0 ||
    is rest of term from [ ] a product?
  
```

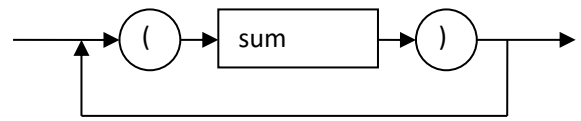

also pretty recursively

We can use it to check (*parse*) whether an entered term corresponds to the selected syntax. If this is the case, you can continue working with it. Our mathematician *Paul* here asks the *Parser*.

```

set term to ask for a term
ask Parser for is [ ] a correct term? of Parser with inputs term
true
  
```

Of course, he packs this query in a separate block to give the impression that he can answer something like this himself. 😊

Paul term $(3x^2-1)(2-x^3)$



13.3 Derivation of Function Terms

We now want to determine the first derivation of correct function terms. We collect the necessary methods from the parser again. Since there are only two possibilities for the internal structure of terms, the first approach is simple.

When applying the summation rule, we must determine and derive the summands. Because we have defined unsigned numbers, we treat them separately, that is, we add a "+" if necessary and then split the sign again. Then the different possibilities are treated according to the rules of mathematics.

When applying the sum rule, script variables were used for a change. This shortens the procedure a little bit.

```

+derivation of + summand + summand +
if letter 1 of summand = + or letter 1 of summand = -
  set summand to Rest von summand ab 2
else
  if is summand a number?
    report 0
  else
    if letter 1 of summand = x
      if length of rest of summand from 2 = 0
        report 1
      else
        if rest of summand from 2 = 2
          report join rest of summand from 2 x
        else
          report join rest of summand from 2 - 1
    else
      if length of rest of summand from 2 = 0
        report beginning of summand to x
      else
        if rest of summand from 2 = 2
          report join beginning of summand to x x rest of summand from 2 x
        else
          report join beginning of summand to x x rest of summand from 2 - 1
  
```

```

+derivation of + term +
if is term a sum?
  report apply the rule for sums to term
else
  report apply the rule for products to term
  
```

```

+apply the rule for sums to + term +
script variables result summand sign h
set result to
set sign to
set h to term
if not letter 1 of term = + or letter 1 of term = -
  set h to join term
repeat until length of h = 0
  set sign to letter 1 of h
  set h to Rest von h ab 2
  if length of beginning of h to + = 0
    if length of beginning of h to - = 0
      set summand to h
      set h to
    else
      set summand to beginning of h to
      set h to join rest of h from
    else
      if length of beginning of h to + = 0
        set summand to beginning of h to
        set h to join rest of h from
      else
        if length of beginning of h to < length of beginning of h to
          set summand to beginning of h to
          set h to join rest of h from
        else
          if length of beginning of h to = length of beginning of h to
            set summand to h
            set h to
          else
            set summand to beginning of h to
            set h to join rest of h from
  set summand to derivation of summand summand
  if not summand = 0
    set result to join result sign summand
  if length of result = 0
    report 0
  else
    if letter 1 of result = +
      set result to Rest von result ab 2
    report result
  
```

Only the product rule is still missing. We can just write them down - with the addition of some brackets.

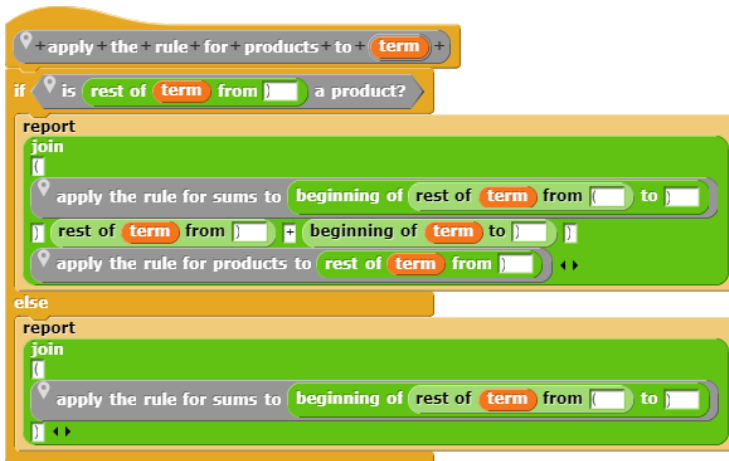

The result can even be read to some extent:

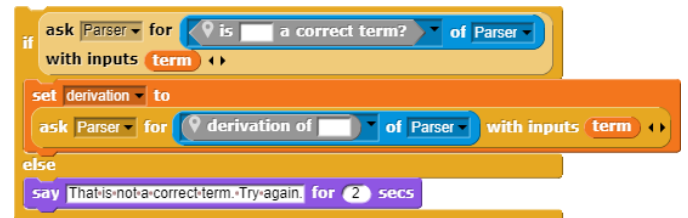
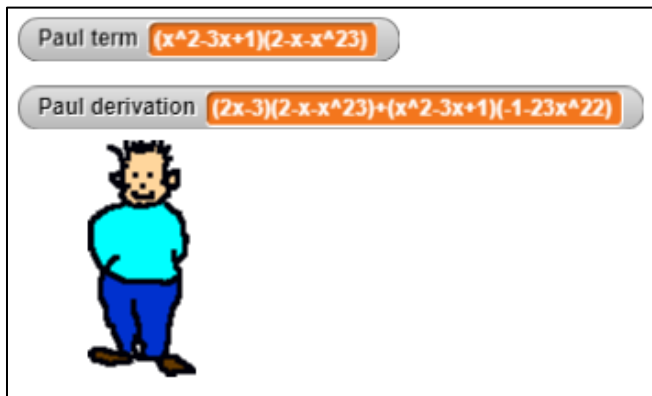

It should be noted that the derivatives do not necessarily correspond to our simplified definition of function terms and therefore often cannot be "further processed".

13.4 Calculation of Function Results and Graphs

If we can parse function terms, then of course we can also calculate them. The procedure is very similar to parsing, and it is much easier if we already know that the term entered is correct. We leave this work to Paul, who up to now - apart from self-portrayal - was quite superfluous. But, as a mathematician, he can do arithmetic!

We want to calculate function values and then draw the graphs of the function and its first derivative. Paul must be able to draw at least one graph.

The image shows two Scratch scripts side-by-side. The left script is for drawing a coordinate system, and the right script is for graphing a function.

Left Script: Drawing a Coordinate System

- Starts with a "draw a coordinate system" block.
- Hides variables "term" and "derivation".
- Tells "Parser" to "hide".
- Clears the screen.
- Switches to costume "pen".
- Sets pen size to 50%.
- Sets xp to -200.
- Calculates x as xp / 30.
- Calculates y as calculate term (x).
- Calculates yp as y * 30.
- Uses an if-else structure to set pen color based on "color" (1, 2, 3).
- Switches to costume "Paul" and sets size to 100%.
- Repeats 400 times:
 - Change xp by 1.
 - Calculate x as xp / 30.
 - Calculate y as calculate term (x).
 - Calculate yp as y * 30.
 - Go to x: xp, y: yp.

Right Script: Graphing a Function

- Starts with a "draw graph of term with color color" block.
- Script variables: xp, x, y, yp.
- Warp to costume "pen".
- Set size to 50%.
- Set xp to -200.
- Set x to xp / 30.
- Set y to calculate term (x).
- Set yp to y * 30.
- If color = 1, set pen color to black.
- Else if color = 2, set pen color to red.
- Else if color = 3, set pen color to green.
- Else, set pen color to blue.
- Pen up.
- Go to x: xp, y: yp.
- Pen down.
- Repeat 400 times:
 - Change xp by 1.
 - Set x to xp / 30.
 - Set y to calculate term (x).
 - Set yp to y * 30.
 - Go to x: xp, y: yp.
- Switch to costume "Paul".
- Set size to 100%.

In these scripts all blocks already exist - except for one. The calculation of a function term at position x is still missing. We specify the corresponding scripts only because they are very similar to those of the parser.

```

+calculate+ term + (+ x # +) +
if ask Parser for is a sum? of Parser with inputs term
report calculate sum term ( x )
else
report calculate product term ( x )
    
```

```

+calculate+ sum + term + (+ x # +) +
script variables summand rest pos+ pos-
if length of term < 1
report 0
else
if not letter 1 of term = + or letter 1 of term = -
set term to join term
set pos+ to length of beginning of Rest von term ab 2 to
set pos- to length of beginning of Rest von term ab 2 to
if pos+ = 0
set pos+ to 999999
if pos- = 0
set pos- to 999999
if pos+ > pos-
set summand to
join letter 1 of term beginning of Rest von term ab 2 to
set rest to join rest of Rest von term ab 2 from
else
if pos+ = pos-
set summand to term
set rest to
else
set summand to
join letter 1 of term beginning of Rest von term ab 2 to
set rest to join rest of Rest von term ab 2 from
if length of rest = 1
report calculate summand summand ( x )
else
report calculate summand summand ( x ) + calculate sum rest ( x )
    
```

```

+calculate+ summand + term + (+ x # +) +
script variables number exponent sign
set number to 0
set exponent to 0
set sign to letter 1 of term
set term to Rest von term ab 2
if length of term = 0
report 0
else
if ask Parser for is a number? of Parser with inputs term
if sign = +
report term
else
report -1 x term
else
if length of beginning of term to x = 0
set number to 1
else
set number to beginning of term to x
if length of rest of term from x = 0
set exponent to 1
else
set exponent to rest of term from x
if sign = +
report number x x ^ exponent
else
report -1 x number x x ^ exponent
    
```

```

+ x # + ^ + y # +
script variables result
set result to 1
repeat y
set result to result x x
report result
    
```

```

+calculate+ product + term + (+ x # +) +
ask Parser for is a product? of Parser
with inputs rest of term from
report
calculate sum beginning of rest of term from to ( x ) x
calculate product rest of term from ( x )
else
report calculate sum beginning of rest of term from to ( x )
    
```

With their help Paul can now shine!

```

when clicked
clear
set term to 
set derivation to 
go to x: 190 y: 0
say 
set term to ask for a term
if ask Parser for is a correct term? of Parser
with inputs term
draw a coordinate system
draw graph of term with color 2
set derivation to
ask Parser for derivation of of Parser with inputs term
if ask Parser for is a correct term? of Parser
with inputs derivation
draw graph of derivation with color 3
else
say The derivation is not of the given syntax. I can't draw it.
else
say That is not a correct term. Try again! for 2 secs
show variable term
show variable derivation
pen up
go to x: 210 y: -110
show

```

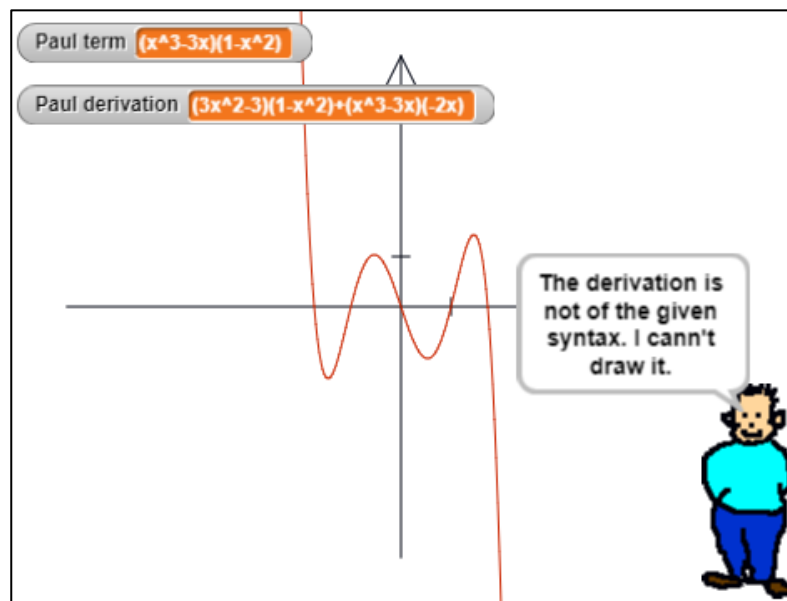

13.5 Tasks

1. a: Make the outputs a little more **readable**.
b: Combine results in the derivation so that they correspond to the given syntax and the graph can be drawn.
2. a: Define **signed numbers** and change the processing of the terms accordingly.
b: Proceed accordingly for **floating point numbers** (numbers with decimal points).
3. a: Define **advanced function terms**, which can contain quotients, using syntax diagrams.
b: Enable parsing of these function terms by writing appropriate predicates.
c: Form derivatives by implementing the quotient rule as a string operation.
4. Perform task 3 accordingly for **trigonometric functions**.
5. Allow function terms that require the use of the **chain rule**. Implement appropriate predicates and string functions.
6. a: Let the graphs of the **other function types** draw after they have been parsed.
b: Allow a selection of the graphs to be drawn (function, first and second derivation).
7. Introduce a **"function calculator"**: a function term is entered first. If this is correct, values can be entered repeatedly, and the corresponding values are determined.

14 Artificial Plants: L-Systems

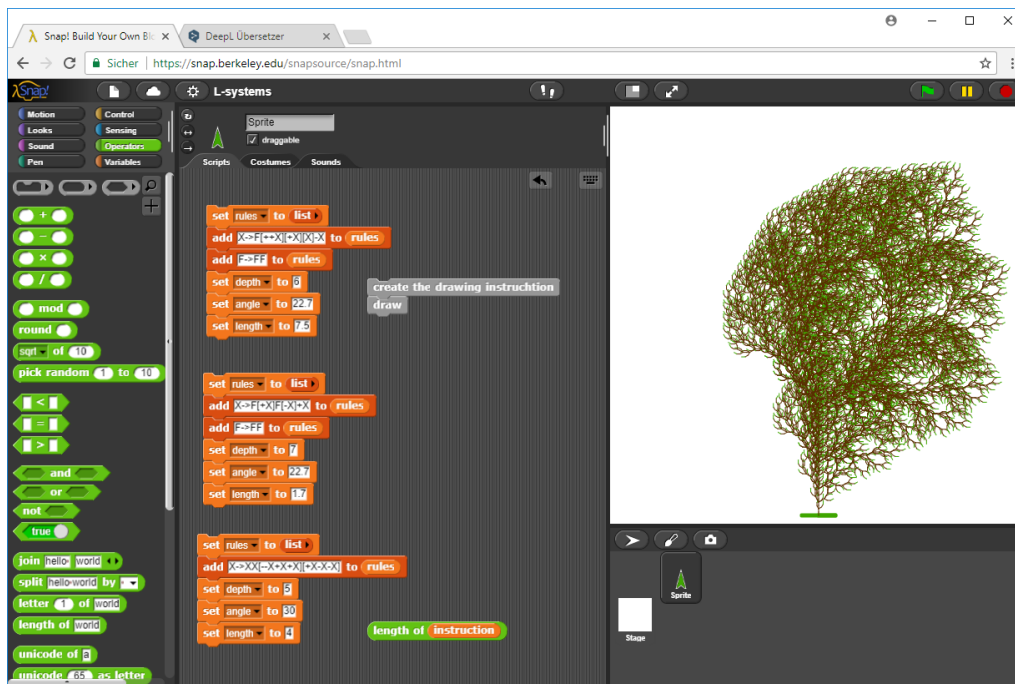

Contents:

- using a list as a stack
- simple context-free language
- use of Turtlegrafik

14.1 L-Systems

In Aristid Lindenmayer's systems³³, plants are described by a rule system that creates the drawing instruction for a *turtle* from an *axiom*, a first character, by substitution. One can imagine that - starting from a shoot - the plant is drawn until the next branching point. This position is stored on a stack, then the branches are written one after the other, returning to branching after each branch. Turtle masters only forward movement (F) and turns around a fixed angle ($+$ and $-$). Saving the turtle position and direction and restoring this state is symbolized by square brackets ($[$ and $]$). A simple plant with a triple branch can be described by

axiom: X rule: $X \rightarrow F[-X][+X]FX$

If this rule is applied several times, the plant can grow at the positions where an X has been inserted. For the older parts of the plant to grow with it, a rule $F \rightarrow FF$ is often added to the rule system.

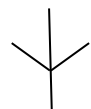

shoot with triple branching

³³ <https://de.wikipedia.org/wiki/Lindenmayer-System>

14.2 Create the Drawing Instruction

First of all, we need a rule system, i.e. a list variable *rules*, to which the desired rules are added line by line as character strings. The character to be replaced is at the very front, then follow \rightarrow and the replacement from character 4 onwards. The recursion depth, the specified angle and the length of the drawing path are also assigned to variables.

```

+ create the drawing instruction +
script variables h i k hit
warp
set instruction to X
repeat depth
  set h to 
  set i to 1
  repeat until i > length of instruction
    set hit to false
    set k to 1
    repeat until k > length of rules
      if letter 1 of item k of rules = letter i of instruction
        set h to join h Rest von item k of rules ab 4
        set hit to true
        change k by 1
      if not hit
        set h to join h letter i of instruction
        change i by 1
    set instruction to h
  
```

When creating the drawing instruction, we start with the *axiom*. Then we create an auxiliary string *h* in which the substitutions are performed per run: whenever a character to be replaced is found in the old character statement, we append the replacement to *h*. Finally, *h* replaces the drawing instruction and the next replacement cycle is started.

Preferences

```

set rules to list
add X->F[+X][+X]X to rules
add F->FF to rules
set depth to 6
set angle to 22.7
set length to 7.5
  
```

The drawing statement can be quite long. Therefore "warp" is used to accelerate the whole thing.

```

length of instruction 84259
  
```

14.3 The Stack Operations

We use a simple list as a stack for storing the turtle positions. Operations are only performed at the top of the list - we already have a *stack*. Storing is usually done by a *push* operation. We store a three-element list with x- and y-positions as well as the current *direction*. Use *pull* to retrieve the last saved position and remove it from the stack.

```

set stack to list
+ push position +
insert list x position y position direction at 1 of stack
+ pull position +
script variables p
set p to item 1 of stack
delete 1 of stack
report p
  
```

14.4 Drawing the Plants

Drawing the plants is very easy because all our sprites can be used as turtle. We enlarge our working area to 500x500 (select *stage size...* in the *Settings* menu) and let the turtle draw the "foot" on which the plant grows. The character string is then processed character by character using the character instructions, with the corresponding turtle operation or a stack operation being executed for each character. As a small delicacy we draw the "tips" of the plant green. (*Peaks can be recognized by the fact that the next step is to return to the last turtle position, i.e. a pull operation follows.*)

Examples:

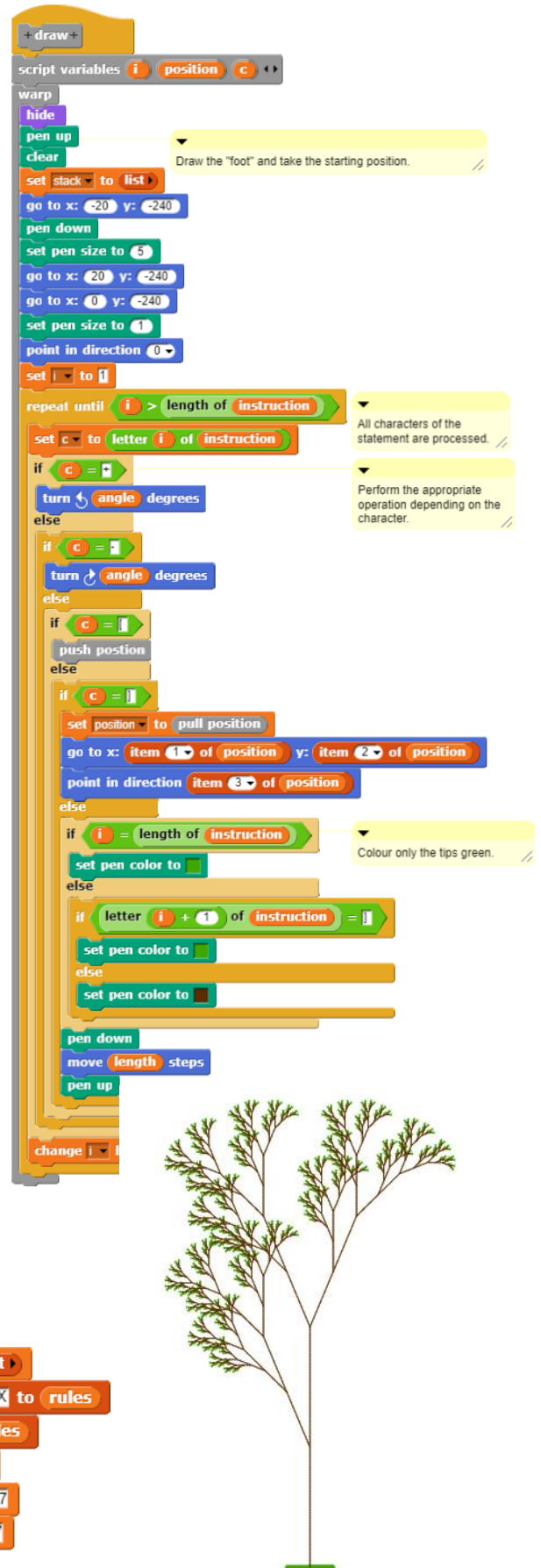
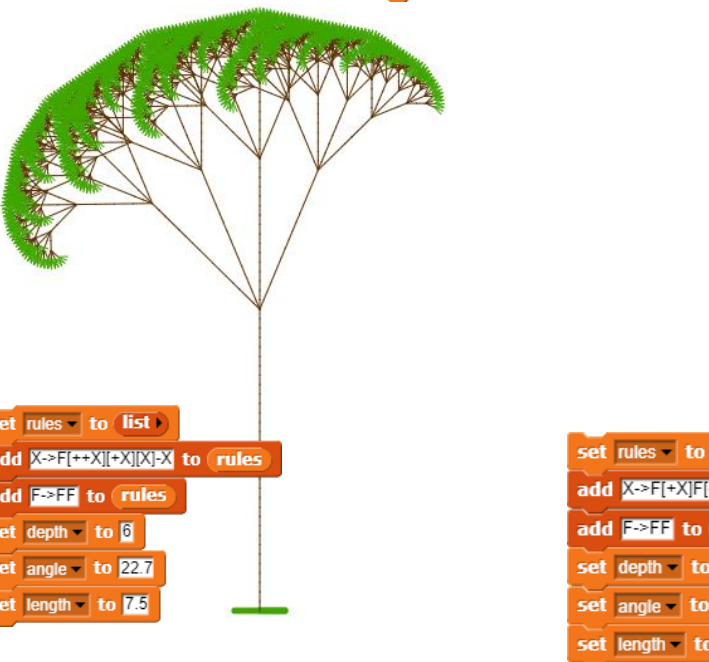

14.5 Tasks

1. a: Search the web for **grammars** for L-systems. Create the appropriate plants.
b: Select a plant species, e.g. a certain tree species, and study its construction thoroughly using pictures. Pay particular attention to growth areas. Then describe their structure using an L-system grammar. Check the result using the program.
2. a: Why are the grammars considered so far "**context-free**"? What does this mean for the plants produced??
b: Check the web to see if grammars other than context-free are used to describe artificial plants. If yes: why actually?
3. a: In the program the tips of the branches (as "leaves") were dyed green. Replace these green pieces with more beautiful **leaves**.
b: Transfer the principle to drawing the thickness of the branches. Just come up with something! 😊
4. Plants don't always grow the same: there are storms, raging children, hobby gardeners, weather disasters, ... Bring some **randomness** into play to produce differently shaped plants of the same type.
5. a: The stack operations were always performed at the top of the list. Could one also take the end? If yes: why?
b: Would something change if you insert at the beginning of the stack and remove the positions at the end? If yes: why?
6. The users of the L-system program can enter anything else as grammar. Check their entries with a **parser** before trying to create the plant.
7. a: How would the rules for L-systems be changed if we wanted to create **three-dimensional plants**? What did this mean for the drawing of the plants? Are there turtles for three-dimensional drawing?
b: Find out about topics where artificial plants are used on the net.
8. Do they also draw artificial animals? Artificial people? If yes: where? How do they do that?

15 Automata

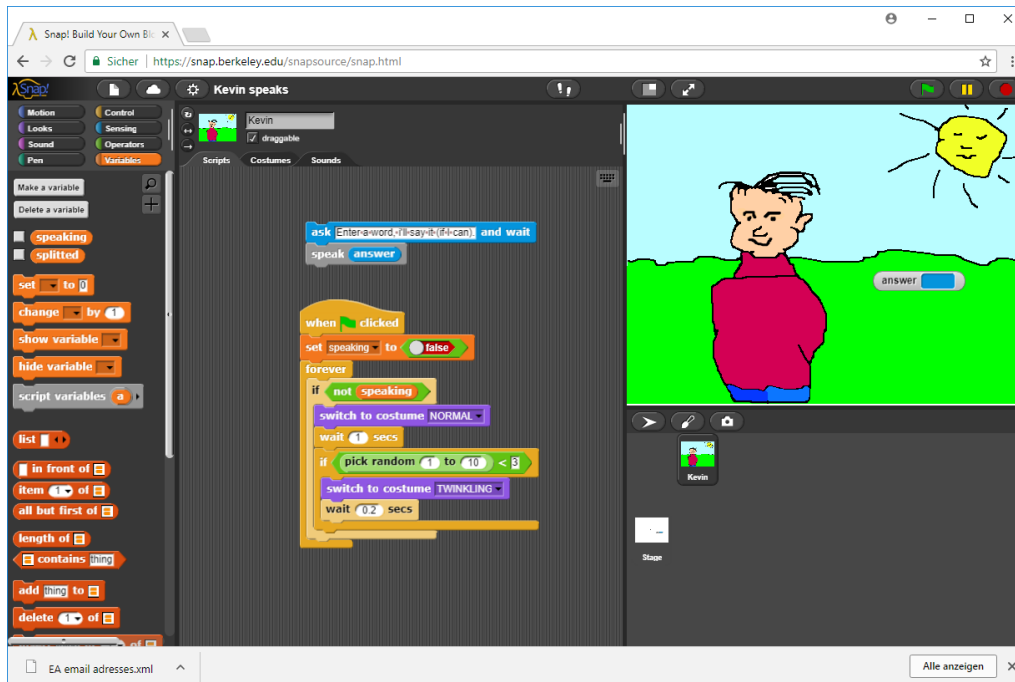

Contents:

- finite automaton as a predicate
- hyphenation and pronunciation
- coupled Turing machines and control structures

15.1 Correct Mail Addresses

We want to use a finite automaton (FA) to check if a mail address is correct. To do this, of course, we must first know what "correct" means. We specify a syntax diagram:

mail address:

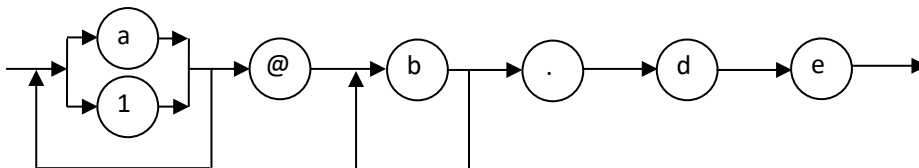

In this simplified form, the participant names consist of the characters *a* and *1* (as substitutes for letters and special characters) in an arbitrary sequence, followed by the usual *@*. The mail server name consists only of *b*, and - separated by the dot - follows as domain name *de*.

For example, correct email addresses are *a@b.de* *a1a@bbb.de*, *1@c.com* would be wrong.

Translated into a finite automaton we get its state diagram:

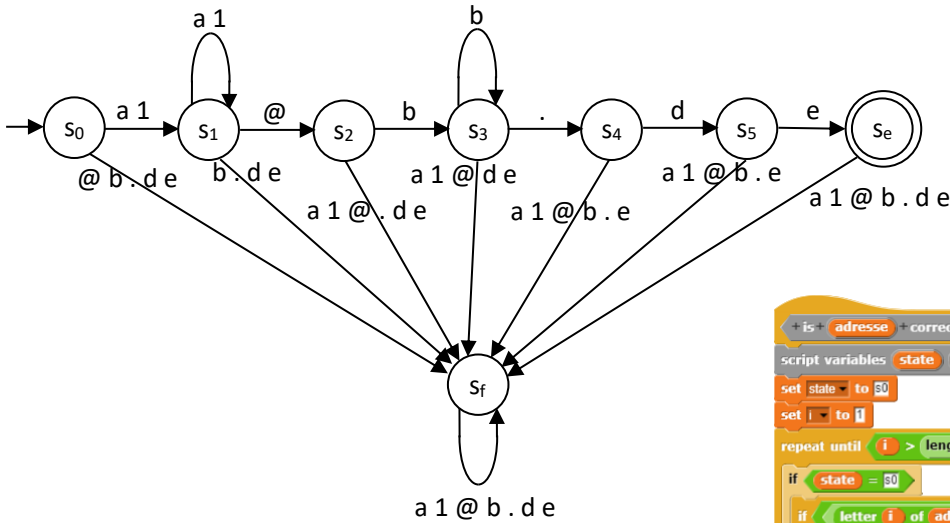

Translation into a *Snap!* script can well be done as a predicate, because the machine's response is *true* (the final state s_e has been reached) or *false* (another state has been reached, typically the error state s_f). In the script, the checked address is scanned character by character. Starting from the initial state s_0 , the system checks whether the current character is permitted. If it is, the system changes to the next state specified in the state diagram, otherwise to the error state. The script is quite long but consists only of nested alternatives that represent a direct translation of the state diagram.

When checking the mail addresses, the predicate created can be used.



```

+ is+ adresse +correct?+
script variables state i
set state to S0
set i to 1
repeat until i > length of adresse
  if state = S0
    if letter i of adresse = a or letter i of adresse = 1
      set state to S1
    else
      set state to Sf
  else
    if state = S1
      if letter i of adresse = @ or letter i of adresse = .
        set state to S2
      else
        set state to Sf
    else
      if state = S2
        if letter i of adresse = b
          set state to S3
        else
          set state to Sf
      else
        if state = S3
          if letter i of adresse = .
            set state to S4
          else
            set state to Sf
        else
          if state = S4
            if letter i of adresse = d
              set state to S5
            else
              set state to Sf
          else
            if state = S5
              if letter i of adresse = e
                set state to Se
              else
                set state to Sf
            else
              set state to Sf
          change i by 1
        report state = Se
    
```

15.2 Hyphenation: Kevin Speaks³⁴

Mealy machines can be used to implement simple hyphenation that works surprisingly well. In addition, we want to get Sprite *Kevin* to pronounce the entered words. The second sounds more difficult than it is: if we have the syllables, then for each syllable we can create an image with the mouth position whose name corresponds to the syllable (e.g. *AU.png*) and record the spoken syllable (e.g. as *AU.wav*). We drag these files into the *Costumes* or *Sounds* areas of *Snap!* and call them from there.

We start from the adjoining, very simple Mealy machine. Its input alphabet consists of vowels (*v*), consonants (*k*) and other separators (*t*). It inserts some separators for hyphenation, but of course it works incompletely and partly wrong. It separates the strings *vkv* in *v-kv* and *vkkv* in *vk-kv*. First of all, we have to be able to enter a word into the program. For this we use the command *ask and wait*. The result is available as *answer* in the *Sensing* palette. This word is to be separated.

Since users of programs never follow the guidelines, we first make sure that only capital letters appear in the word. To do this, we must be able to convert at least one single character into uppercase if necessary. We have already written the function for this in Vigenère encryption, as well as the function for the conversion of whole words.

A word converted to upper case can be similarly transformed into a sequence of the characters *v*, *k* and *t*. The vowels are easy to find, the consonants are letters that are not vowels, the rest is treated as separators. For practical reasons, a *t*-character is added last. This means that at least one character is always present - and we always reach the state *0* at the machine at last.

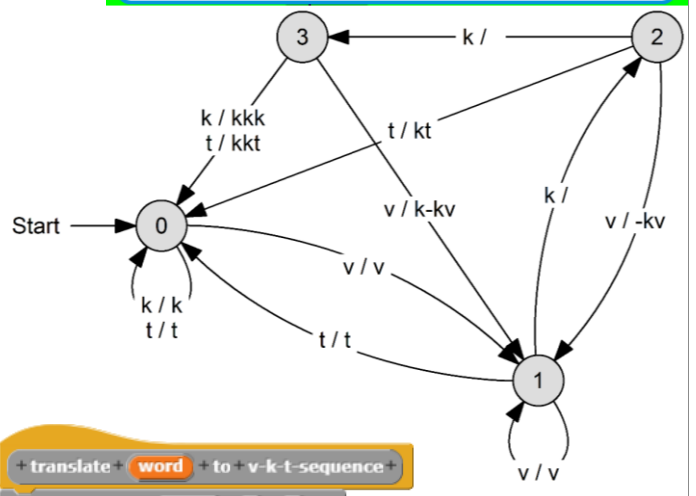
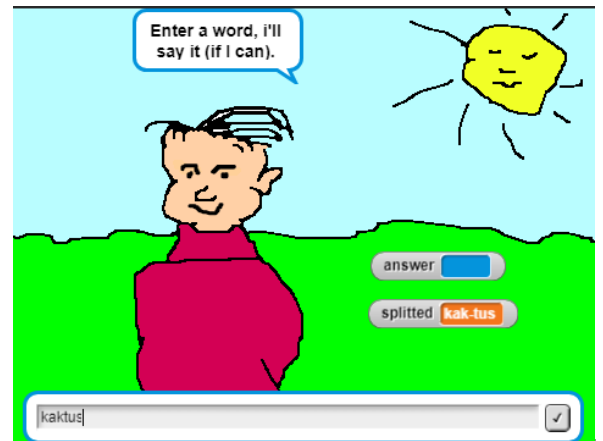

```

+ translate + word + to + v-k-t-sequence +
script variables result i c
set result to 
set i to 1
repeat length of word
  set c to letter i of word
  if c = A or c = E or c = I or c = O or c = U
    set result to join result v
  else
    if unicode of c > 64 and unicode of c < 91
      set result to join result k
    else
      set result to join result t
  change i by 1
set result to join result t
report result
    
```

³⁴ based on an idea by Wilfrid Herget.

It's time to split the sequence. We read character for character *v*, *k* or *t* and write down our automaton: Depending on the state, the next state is specified, and characters are added to the output.

Attention: the states are handled by nested alternatives, so that after a change of state the following statement is not executed without a new character being read in first!

Finally, we must convert the *vkt* sequence back to the original characters - with the separators between them. To do this, we run through the *vkt* sequence with the separators (index: *i*) as a pattern and build the result sequence from the characters of the entered word (index *j*). However, we only change *j* if *i* does not point to a separator (-) in the pattern

```

+ create splitted + word + from + template + template +
script variables result i j
set result to
set i to 1
set j to 1
repeat length of template
  if letter i of template =
    set result to join result
  else
    set result to join result letter j of word
    change j by 1
  change i by 1
report result
    
```

We can now use these functions one after the other to separate a word:

```

script variables pattern
set pattern to change in capitals
set pattern to translate to v-k-t-sequence
set pattern to split vkt pattern
set splitted to create splitted answer from template pattern
    
```

And of course, we can bundle such instruction sequences in a new block.

```

+ split + word +
report create splitted word from template
split vkt translate change word in capitals to v-k-t-sequence
    
```

```

+ split + vkt + word +
script variables state result i c
set state to 0
set i to 1
set result to
repeat length of word
  set c to letter i of word
  if state = 0
    if c = v
      set state to 1
    set result to join result c
  else
    if state = 1
      if c = k
        set state to 2
      else
        if c = t
          set state to 0
        set result to join result c
    else
      if state = 2
        if c =
          set state to 3
        else
          if c =
            set state to 0
            set result to join result kt
          else
            set state to 1
            set result to join result kv
      else
        if c = v
          set state to 2
          set result to join result kkv
        else
          set state to 0
          if c = t
            set result to join result kkt
          else
            set result to join result kkk
    change i by 1
report result
    
```

The words, divided into syllables, should be pronounced by the computer, similar to navigation systems, automatic time announcements or other "computer voices". If we store syllables instead of whole words, we need considerably less storage space, because the syllables can be used several times. (But it doesn't get any nicer!)



First, we choose a few (here: German) words: *Autobahn, autonom, Automat, Pronom, Promille, Kamille, Kamel, Kaktus*. For short syllables we can use the built-in sound recorder. Or we speak the syllables (e.g. in *Scratch*) into the microphone and save the WAV files under the name of the syllable in capital letters. We drag the sound files into the *Sounds* section of *Snap!*

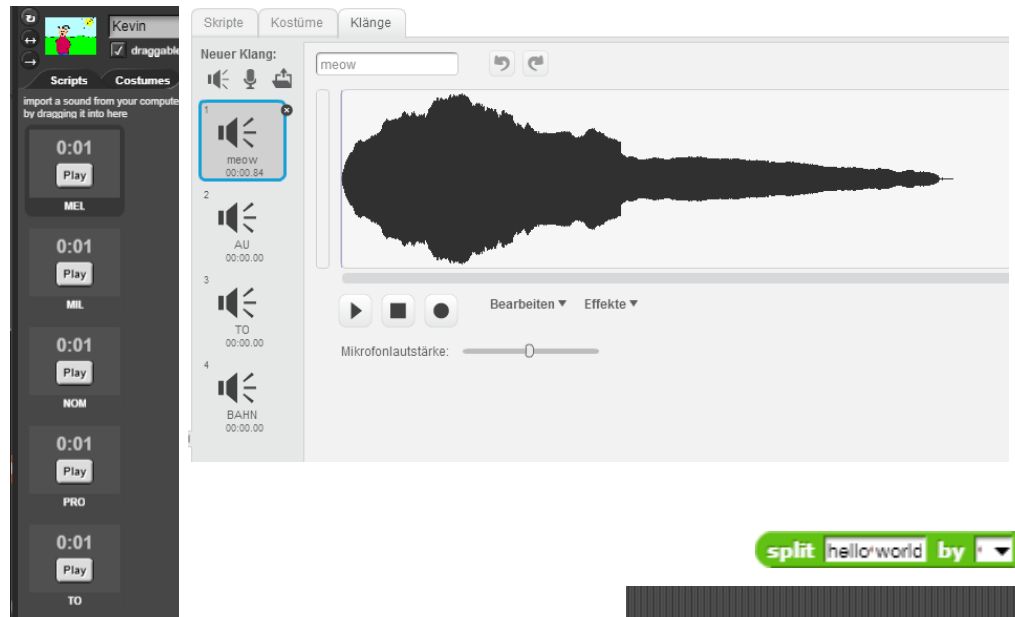

Since the entered words have been separated (see above), we get (approximately) the syllables when we "decompose" the word. To do this, *Snap!* provides the *split by* command. The block creates a list of the parts of a word. If we enter *Au-to-bahn* and separate at the sign "-", then we get:



If our sound files have the same name as the syllables, we can play them with *play sound until done* by selecting the syllable as input parameter of the block.

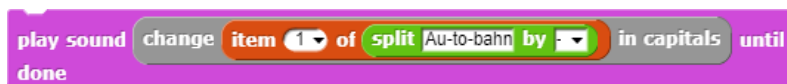

We can let the computer pronounce words by

- separating the entered word
- and breaking it down into its syllables,
- from this list, "pronounce" the first element in each case
- and delete it from the list
- until the list is empty.

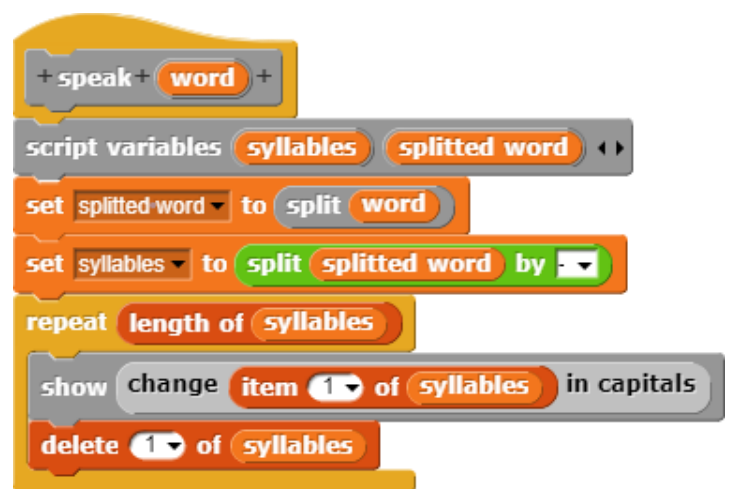

For each of the different syllables we draw a costume for Kevin.

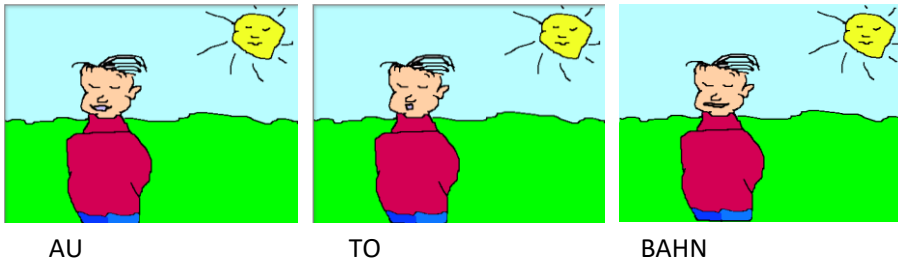

These costumes are displayed while speaking the syllables.

Words are pronounced by calling this script with the corresponding syllables.

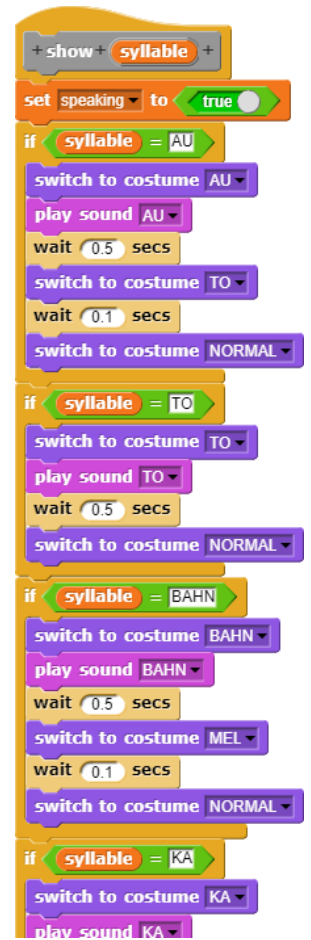
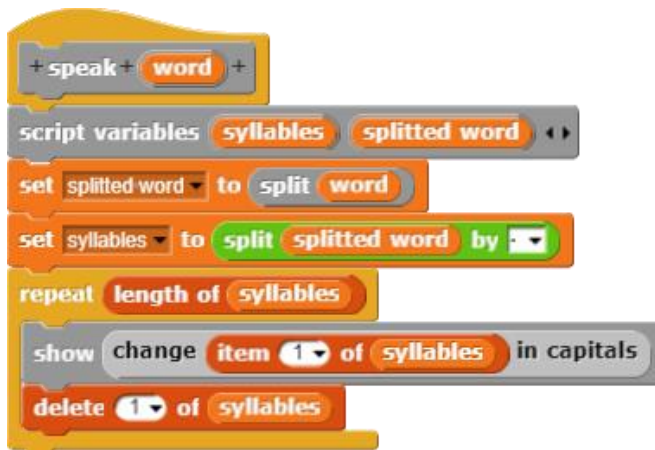

15.3 Coupled Turing Machines ³⁵

If one describes Turing machines by state graphs, then the meaning, which is assigned to this model, seems to the learners strongly exaggerated, because the problems, which can be described by a still readable graph, are nevertheless quite simple. Much more powerful tools can be generated in the model of coupled Turing machines, in which the initial state of the next machine corresponds to the final state of its predecessor. More and more powerful designs can be created from very simple systems. The result is a kind of macro language in which topics of predictability and decidability can be formulated.

Our system of elementary Turing machines works on a Turing tape, which contains only ones and zeros. The zeros serve as separators, so that numbers must be represented by ones. The number n is coded accordingly by $n+1$ ones, so that the zero also has a code. In the *standard position*, the head of the Turing machine is above the one on the far right. All groups of ones must be separated by exactly one zero and there are two zeros at the left edge of the band. After the work the machine is back in the standard position. The next machine starts working out of this.

The *1-* and *0-machines* are available as elementary machines, which write the corresponding character at the head position on the tape. That's all they're doing. The *small left machine l* moves the head of the Turing machine one position to the left, the *small right machine r* to the right. There is also a *testing machine p* that checks which character is present at the current head position. Depending on the result, it branches into one of two states to which further machines can then be coupled. That's about it.

Because they are often needed, we design two new machines, the *large left machine L*, which runs to the left over a group of ones, and correspondingly a *large right machine R*. These can be realized as follows:

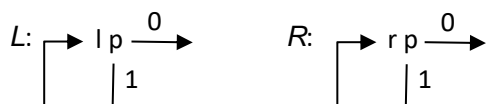

The *copying machine K1* copies a group of ones to the right.

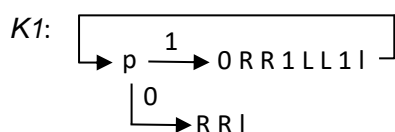

If the copying machine *K2* copies one group of ones over a second group to the right, then we can already calculate sums with the help of a *Turingadder A* by:

A: $K2 K2 L 1 R 1 0 1 0 1$

Give it a try!

³⁵ from Eckart Modrow, Theoretische Informatik mit Delphi, emu-online, 2005

Instead of testing the machines on paper, we want to develop a macro language in which our coupled Turing machines can be realized. Since we don't want to use the normal *Snap!* command palettes, we disable them after right-clicking on a palette (*hide primitives*). The palette is empty after that.

For the simulation of the machines, we need a tape consisting of ones and zeros. We choose a list *tape*, because it can be easily changed in length. For the display we create some images with ones and zeros of different sizes, whereby the head position is displayed in yellow. The working speed and the cell size should be changeable on the screen. Overall, we need the variables *initial caption*, *tape*, *tape length*, *pos*, *cell type* and *pause(ms)*.

The initial caption must be asked, and an appropriate band must be generated and displayed.

The default position must be taken on this tape, where the value of the variable *pos* is determined.

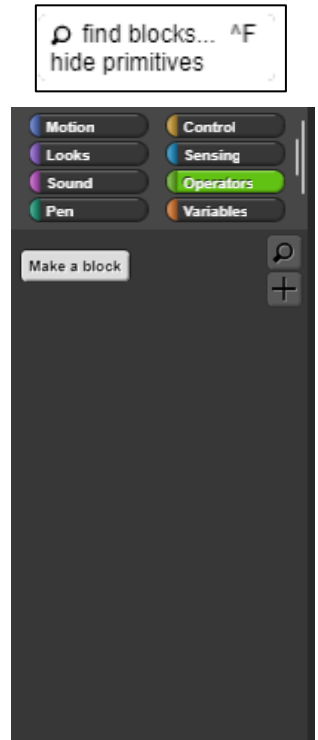

```

+show+tape+
script variables i
set i to 1
hide
clear
go to x: -230 y: 0
show
repeat until x position > 250
  if item i of tape = 0
    if cell type = 1
      switch to costume null-1
    else
      switch to costume null-2
  else
    if cell type = 1
      switch to costume eins-1
    else
      switch to costume eins-2
  stamp
  if cell type = 1
    move 10 steps
  else
    move 20 steps
  change i by 1
show head
    
```

```

+enter+initial+caption+
script variables i
switch to costume Turtle
go to x: -200 y: -120
ask initial caption? and wait
set initial caption to answer
set tape to list 0 0
set i to 1
repeat length of initial caption
  add letter i of initial caption to tape
  change i by 1
repeat until length of tape > tape length
  add 0 to tape
    
```

```

+go+to+standard+position+
script variables i
set i to tape length
repeat until i < 2 or item i of tape = 1
  change i by -1
set pos to i
    
```



The tape is then displayed by "stamping" images of the costumes side by side on the stage.

Altogether we get as start command sequence:

```

enter initial caption
go to standard position
show tape
    
```

To show the head position we calculate its screen coordinates and switch to one of the yellow costumes.

The elementary machines can now be quickly generated:

```

+ 1 +
if pos > 1
change pos by -1
show head

+ 1 +
if pos < tape length
change pos by 1
show head

+ 0 +
replace item pos of tape with 0
if cell type = 1
switch to costume null-1
else
switch to costume null-2
stamp
show head

+ 1 +
replace item pos of tape with 1
if cell type = 1
switch to costume eins-1
else
switch to costume eins-2
stamp
show head

+ show + head +
if cell type = 1
go to x: -230 + 10 * pos - 1 y: 0
else
go to x: -230 + 20 * pos - 1 y: 0
if item pos of tape = 0
if cell type = 1
switch to costume null-aktuell-1
else
switch to costume null-aktuell-2
else
if cell type = 1
switch to costume eins-aktuell-1
else
switch to costume eins-aktuell-2
show
wait pause(ms) / 1000 secs
    
```

The generation of the testing machine p is somewhat more complicated, because it must be able to execute two different scripts - depending on the tape letter. These scripts must therefore not be evaluated as parameter values BEFORE the p -machine call is executed, but two scripts are passed, which are to be executed AFTER the call, depending on the tape labeling. The "parameter values" are scripts. When typing the parameters, we select *Command (C-shape)* to prevent the evaluation. The parameters are identified by a λ as scripts.

Use programs as data:
C-shape code

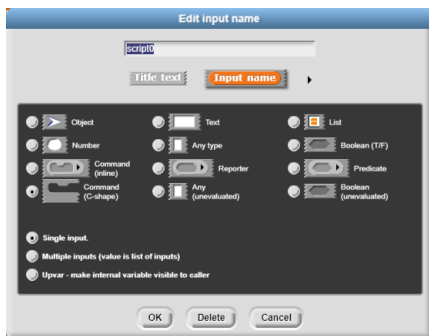

```

+ p + -0-> + script0 λ + -1-> + script1 λ +
if item pos of tape = 0
run script0
else
run script1
    
```

With these machines, the others can be developed "normally recursively" in *Snap!* as blocks.

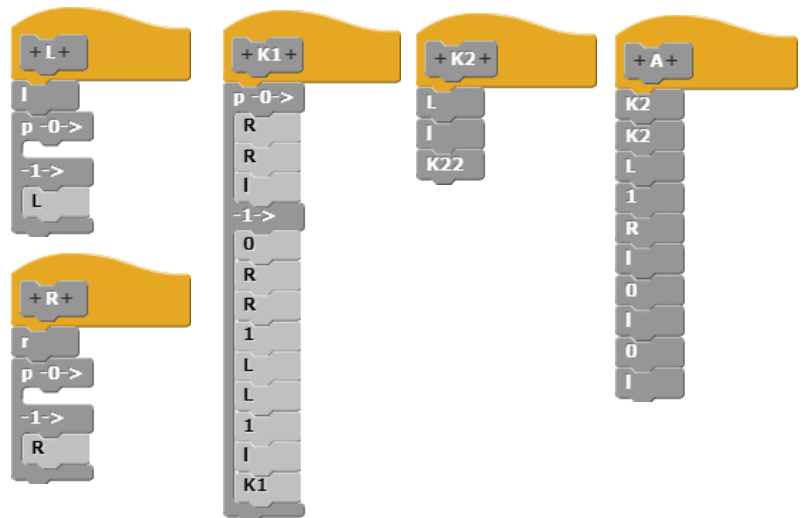

The work of the machines can be monitored and thus checked on the screen. So after that they are used as new blocks for more complex problems.

Instruction set of the Turing machines

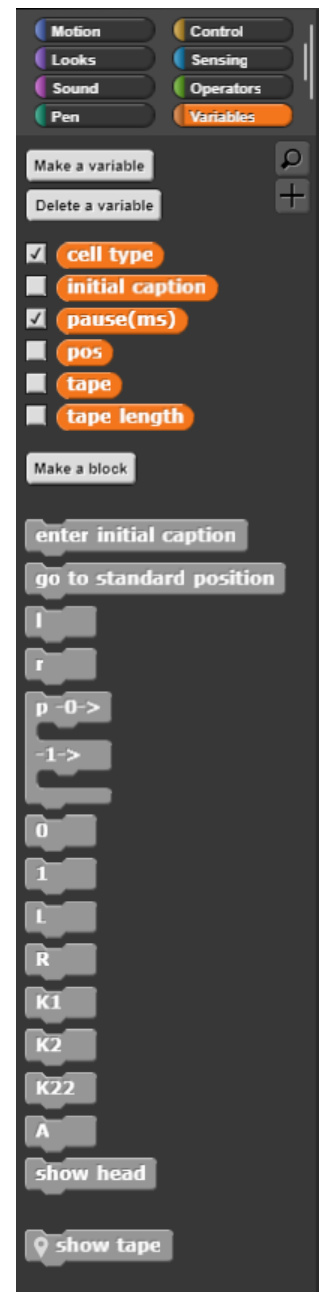
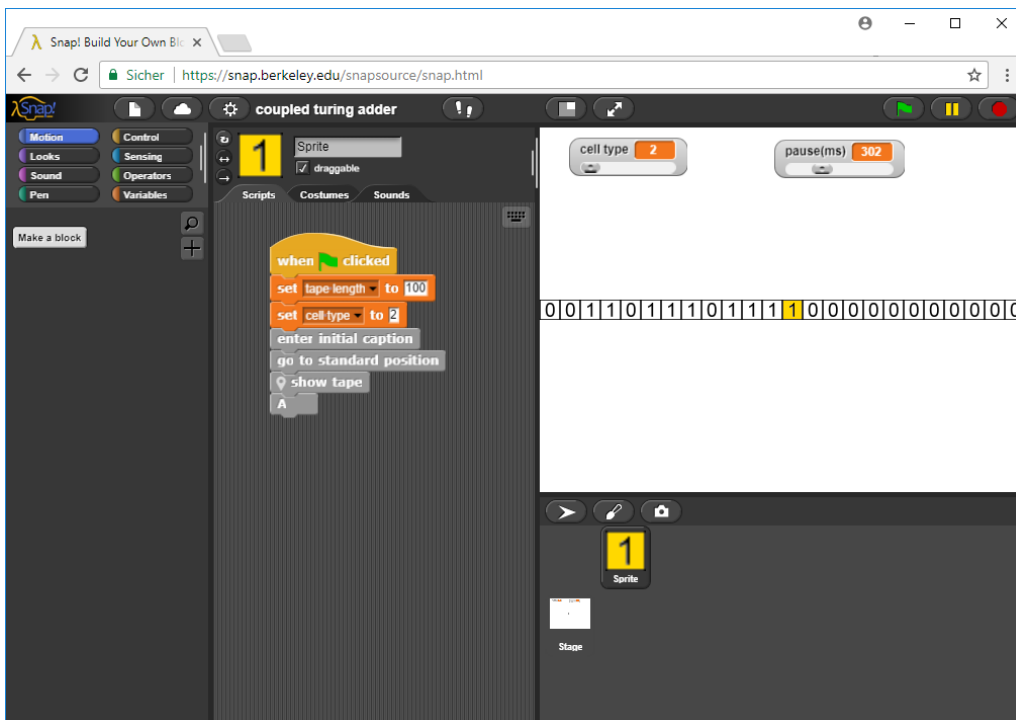

15.4 Cellular Automata: Iterated Prisoner's Dilemma³⁶

We want to build a cellular automaton based on the prisoner's dilemma³⁷, but slightly modified for trading on the Internet. The behavior of the trading partners is simulated by machines that sit on a grid closed in both dimensions. They trade with the partners within a *Von Neumann neighborhood*. As is usual on the Internet, they exchange goods for money. There are different types of business partners:

- *Naive* always cooperate, i.e. provide the correct equivalent value.
- *Fraudsters* never cooperate.
- *Shrewd* people cooperate at first and then react in the same way as their partner did last time.

We describe the behaviour of trading partners using state diagrams:

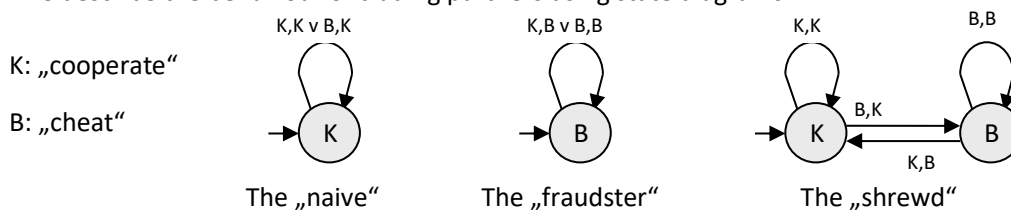

If we arrange such automata in a grid, distribute them randomly and color them according to their state (green as "naive", red as "fraudster" or yellow as "shrewd"), we get an image similar to the following:

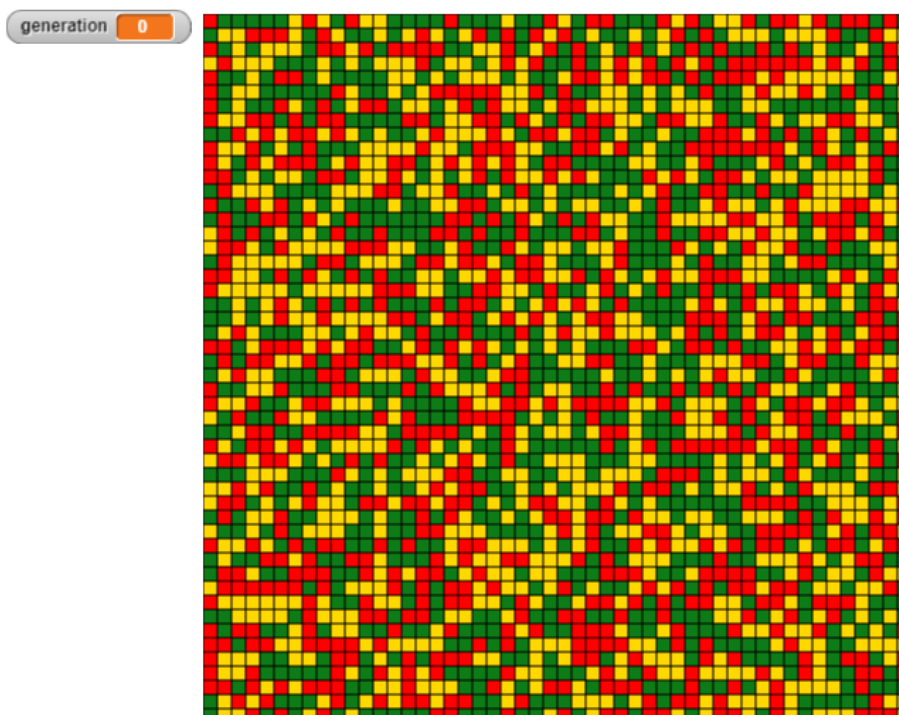

³⁶ from Eckart Modrow, Zelluläre Automaten, LOG IN 127 (2004)

³⁷ <https://de.wikipedia.org/wiki/Gefangenendilemma>

The further procedure is simple: First all partners trade once with their neighbors from the Von Neumann neighborhood, i.e. with the neighbors above, below, left and right. Afterwards all partners evaluate the success of their neighbors. As opportunists, they take over the status of the most successful neighbor or maintain their status when they were better themselves.

In the first generations, the "fraudsters" usually prevail. But then clusters of "naive" or "shrewd" people form and a wild "battle" begins.

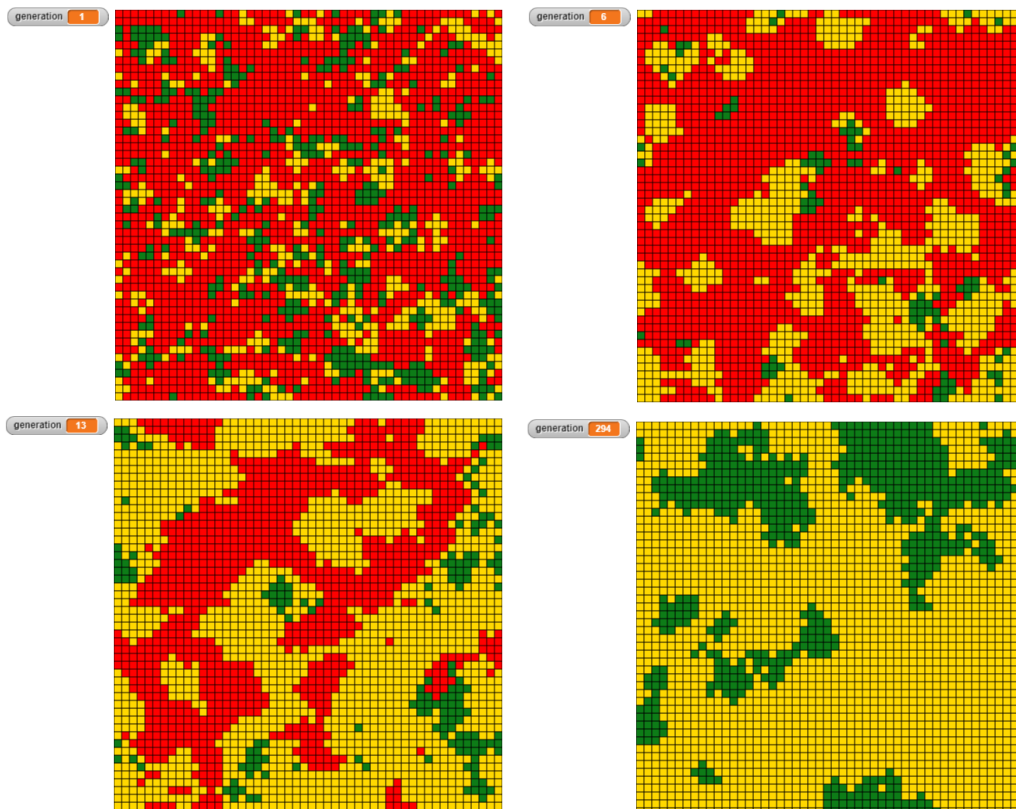

It is true that the "naive" are hard pressed by the "fraudsters". But they do quite well in groups. The "shrewd" usually prevail over the "fraudsters" - depending on the configuration - and cooperate with the "naive". In the end, the "shrewd" usually win - but not always. In groups, the "fraudsters" cheat each other and win nothing, while the "shrewd ones" assert themselves against them and are more successful with the naïve "behind their backs". The processes depend strongly on how the different behavior is weighted.

Global variables are suitable for evaluating the system, e.g. a "gross national product" as the sum of all trading points. Observing the sometimes surprising processes provides starting points for discussing ethical questions. Even if the example cannot, of course, be directly applied to social systems, for most people we have found a new argument for cooperative social behavior, which is not derived from transcendental or philosophical considerations, but from efficiency. It is in clear contrast to the egocentricity of primitive Darwinism, which often dominates public discussion in this respect. A diagram may serve as an example in which, on the one hand, the total numbers of the three types of automata (naive, fraudulent, shrewd) were plotted, and, in addition, the sum of the total trading points achieved by all types, i.e. the "gross national product", is somewhat thicker in blue. One can see very nicely that "social prosperity" (if one wants to derive this from the "trading volume") is contrary to the number of "egoists" - of course under the conditions set.

Among them, fraudsters usually die out for lack of success, and the naive harmonize magnificently with the shrewd - if they are among themselves. If the behavior is weighted differently, fraudsters can be quite successful. So, it depends on the rules of the game who succeeds. You should think about them, not just in a simulation!

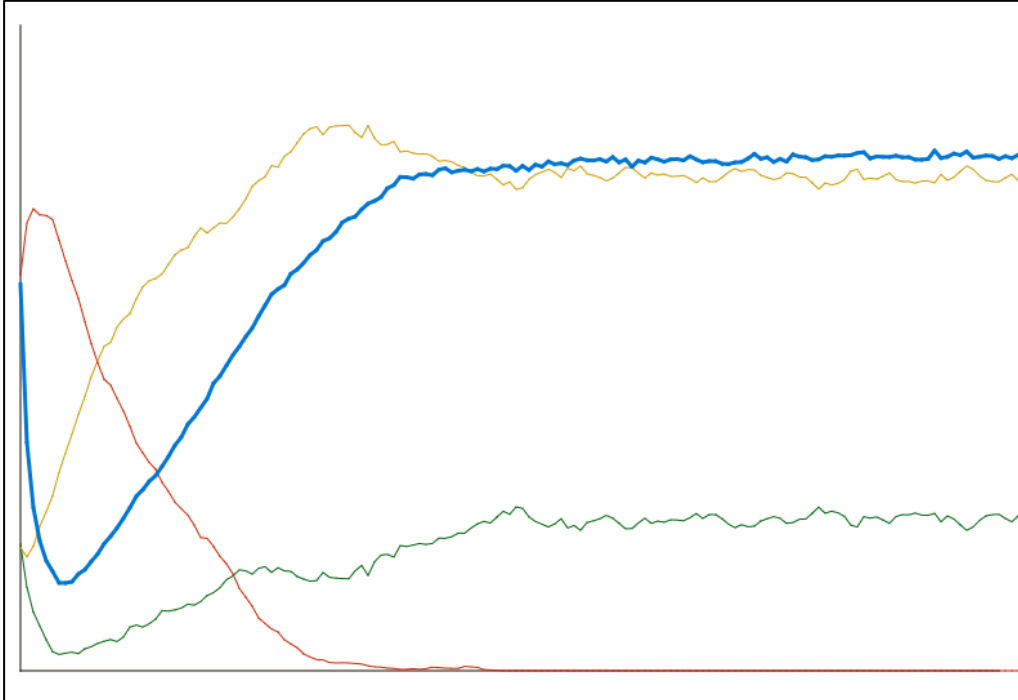

From a programming point of view, the system is rather simple, but sometimes extensive due to the change of viewing direction.

A new automaton can be described by a list of lists, whereby the automata at the grid places correspond to sequences of numbers, which contain on the one hand their state and the reached trading points, on the other hand the "memory" about the past behavior of the neighbors.

```

+ new + automaton +
script variables row a
set nMax to 50
warp
set a to list
repeat nMax
set row to list
repeat nMax
add list pick random 1 to 3 0 0 1 1 1 1 to row
add row to a
report a

```

an automaton is described by the list (state, new state, points, top, bottom left, right). The last four values include the behavior of the neighbors on the last move.

The cellular automaton can be displayed by stamping different coloured costumes (small rectangles) next to each other on the work area. This has been changed to the size 800x600 pixels before.

Once the machine has been created, the new generations are created from the last generation in each case.

```

forever
  delete points
  all are trading
  all change state
  show automaton
  cout states
  change generation by 1
    
```

```

+ show + automaton +
script variables x y state
warp
clear
pen up
set y to 1
repeat nMax
  set x to 1
  repeat nMax
    set state to item 1 of item x of item y of automaton
    if state = 1
      switch to costume naive
    else
      if state = 2
        switch to costume witty
      else
        switch to costume cheater
    go to x: -160 + 10 * x y: 290 - 10 * y
    stamp
    change x by 1
  change y by 1
    
```

The scripts have a very similar structure: a ll grid locations are iterated.

```

+ all + change + state +
script variables x y
warp
set y to 1
repeat nMax
  set x to 1
  repeat nMax
    cell x y changes state
    change x by 1
  change y by 1
set y to 1
repeat nMax
  set x to 1
  repeat nMax
    replace item 1 of item x of item y of automaton with
    item 2 of item x of item y of automaton
    change x by 1
  change y by 1
    
```

```

+ delete + points +
script variables x y
warp
set y to 1
repeat nMax
  set x to 1
  repeat nMax
    replace item 3 of item x of item y of automaton with 0
    change x by 1
  change y by 1
    
```

```

+ all + are + trading +
script variables x y
warp
set y to 1
repeat nMax
  set x to 1
  repeat nMax
    cell x y trades with neighbors
    change x by 1
  change y by 1
    
```

The trade of a cell with its neighbors depends on the one hand on the states of the partial machines, and on the other hand on their previous behavior. Since this data is stored in the machine values, it is easy to retrieve. Shown is the trade with the left neighbor:

determine cell
 Torus world: the opposite edges are connected.
 determine neighboring cell
 is the cell cooperating?
 is the neighbor cooperating?
 save neighbor's behavior "for later"
 if they both cooperate:
 profit between 2 and 10,
 nothing else
 the neighbor is cheated:
 profit between 1 and 20
 cheat on both of them:
 almost no profit

```

+ cell + x # + y # + trades + with + neighbors +
script variables
xp yp cell neighbor neighborCooperates cellCooperates
set cell to item x of item y of automaton
set yp to y
set xp to x - 1
if xp < 1
    set xp to nMax
set neighbor to item xp of item yp of automaton
set cellCooperates to
    item 1 of cell = 1 or
    item 1 of cell = 2 and item 6 of cell = 1
set neighborCooperates to
    item 1 of neighbor = 1 or
    item 1 of neighbor = 2 and item 7 of neighbor = 1
if neighborCooperates
    replace item 6 of cell with 1
else
    replace item 6 of cell with 0
if cellCooperates
    if neighborCooperates
        replace item 3 of cell with
            item 3 of cell + pick random 2 to 10
    else
        if neighborCooperates
            replace item 3 of cell with
                item 3 of cell + pick random 1 to 20
        else
            replace item 3 of cell with
                item 3 of cell + pick random 0 to 1
    
```

Trade with the other three neighbors is almost the same. The differences are only in the positions of the stored behavior.

Once the values of a generation have been determined, they can be counted and compiled in a list - and this results in a diagram.

```

+zähle+ die+ Zustände+
script variables n t b x y zustand g
warp
set n to 0
set l to 0
set b to 0
set g to 0
set y to 1
repeat nMax
  set x to 1
  repeat nMax
    set zustand to item 1 of item x of item y of automat
    if zustand = 1
      change n by 1
    else
      if zustand = 2
        change l by 1
      else
        change b by 1
    change g by item 3 of item x of item y of automat
    change x by 1
  change y by 1
add list n t b g to tabelle
  
```

Table view				
	A	B	C	D
36				
1	Naive	TitForTat	Betrüger	Gesamt
2	482	443	1575	44855
3	290	420	1790	26006
4	242	476	1782	17359
5	197	564	1739	15422
6	185	635	1680	13764
7	150	741	1609	13999
8	143	850	1507	12798
9	129	931	1440	13416
10	124	1043	1333	13375
11	118	1121	1261	14152
12	131	1189	1180	14810
13	127	1282	1091	16339
14	137	1301	1062	17407
15	171	1348	981	17907
16	164	1434	902	19298
17	214	1458	828	19904
18	198	1493	809	22189
19	211	1535	754	23016
20	230	1586	684	24373
21	231	1641	628	25109
22	239	1700	561	26407
23	238	1780	482	27386
24	236	1820	444	29028
25	255	1832	413	30572

```

+draw+ diagram+
script variables i values oldValues
clear
set pen size to 1
set pen color to black
pen up
go to x: -380 y: 250
pen down
go to x: -380 y: -250
go to x: 380 y: -250
set i to 3
set oldValues to item 2 of table
repeat until i > length of table
  set values to item i of table
  set pen size to 1
  set pen color to black
  pen up
  go to x: -380 + 5 * i - 3 y:
  -250 + item 1 of oldValues / 5
  pen down
  go to x: -380 + 5 * i - 2 y:
  -250 + item 1 of values / 5
  set pen color to red
  pen up
  go to x: -380 + 5 * i - 3 y:
  -250 + item 2 of oldValues / 5
  pen down
  go to x: -380 + 5 * i - 2 y:
  -250 + item 2 of values / 5
  set pen size to 3
  set pen color to blue
  pen up
  go to x: -380 + 5 * i - 3 y:
  -250 + item 3 of oldValues / 5
  pen down
  go to x: -380 + 5 * i - 2 y:
  -250 + item 3 of values / 5
  set pen size to 3
  set pen color to blue
  pen up
  go to x: -380 + 5 * i - 3 y:
  -250 + item 4 of oldValues / 150
  pen down
  go to x: -380 + 5 * i - 2 y:
  -250 + item 4 of values / 150
  set oldValues to values
  change i by 1
  
```

15.5 Tasks

1. Develop a finite automaton as a predicate for detection
 - a: **correct license plates** from three different cities.
 - b: **correct IBAN numbers**. You can limit your search to a few banks.
 - c: **passwords** of sufficient complexity. Define beforehand what "sufficiently complex" means.

2. Improve **hyphenation** by taking into account
 - a: double consonants.
 - b: typical prefixes.

3. Develop and test a **coupled Turing machine**,
 - a: that copies one group of ones over another ($K2$).
 - b: which pushes one group of ones to the left to another until the groups are separated only by a zero.
 - c: which multiplies two natural numbers with each other.
 - d: which writes a 1 after two groups of ones, if they are the same length, otherwise a zero.
 - e: that subtracts two natural numbers - if that's possible. If she doesn't, she'll go crazy: she'll run away to the right.

4.
 - a: Replace the trade of all partial automata with the neighbors "per round" by a randomly controlled process in which machines trade with neighboring (with any) partners.
 - b: Replace the Von Neumann neighborhood with a **Moore neighborhood**.
 - c: The machine can easily be converted to an **Ising model** by considering the machines as spin grids. Per round, the majority of the neighboring spins tilt the spin in the middle in their direction. There are various magnetized areas.

5.
 - a: Find out about Stephen Wolfram's **linear cellular automata**.
 - b: Implement the model.

16 Projects

16.1 LOGO for the Poor

Contents:

1. simple text-based programming
2. parsing
3. interpretation of input

We want to develop a small programming language that we can use to write programs for a turtle - that is, for every *Snap!* sprite. The project should show how a text-based language works and how the error messages are generated. We reduce the problem a little by allowing one-letter commands only. If we look at the possibilities of the pen used in *Snap!* and select some of them, we get a possible command set (very small here):

- Mn* moves the turtle by the distance of length *n* in the current direction
- Tn* rotates the turtle on the spot by *n* degrees
- U* lifts the pin
- D* lowers the pin

We add a control structure to these four commands, here: a loop - and the minimal version of a programming language is ready.

Rn{drawing commands }

We cast this rough sketch in the form of syntax diagrams: A turtle program consists of a sequence of commands separated by semicolons. The program ends with a double cross sign.

turtle program:

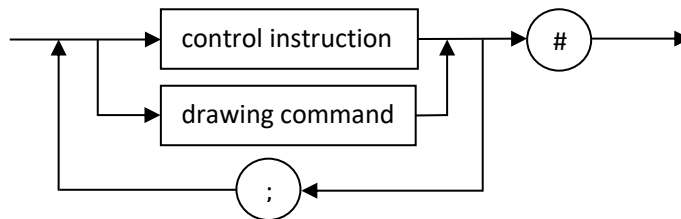

The syntax diagrams can easily be extended by additional commands.

control instruction:

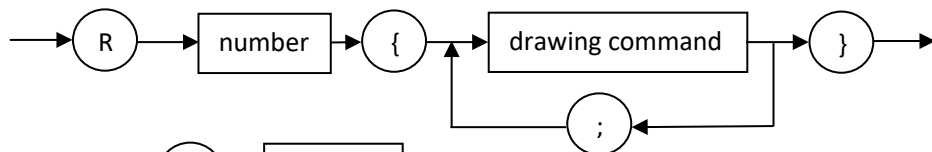

drawing instruction:

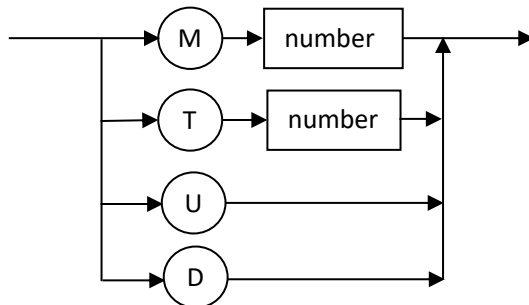

number: natural numbers

Programs are e.g.: *D;R4{M100;T90};U#*
M100;T90;M100;T90;M100;T90;M100;T90#
D;R180{M200;T183};R360{M1;T1}#

We assume that superfluous characters such as spaces are removed from the program first. We can achieve this, for example, by converting entered lowercase letters into uppercase letters and allowing digits and the four special characters ";", "#", "{" and "}". All other characters lead to the error message "ERROR 1: Wrong character in the input!".

The image shows a Scratch script designed to process user input character by character. The script starts with a 'get command' block, followed by a 'script variables' block with 'input', 'result', and 'i' variables. It then asks the user to 'Enter a turtle program' and waits for an answer. The 'input' variable is set to the answer, 'result' is set to an empty string, and 'i' is set to 1. A 'repeat until' loop runs while 'i' is less than or equal to the length of 'input'. Inside the loop, there are four conditional branches:

- Lowercase letters:** If the Unicode of the character at index 'i' is greater than 96 and less than 123, it is converted to uppercase by subtracting 32 from its Unicode value and joined to 'result'.
- Uppercase letters:** If the Unicode is greater than 64 and less than 91, the character is simply joined to 'result'.
- Ciphers:** If the Unicode is greater than 47 and less than 58, the character is joined to 'result'.
- Four special letters:** If the character is one of ";", "#", "{", or "}", it is joined to 'result'.

 If none of these conditions are met, an error message 'ERROR 1: Insufficient character in the input!' is set to 'result', and 'i' is set to the length of 'input'. After the loop, 'i' is incremented by 1, and the final 'result' is reported.

A simple input method with character control.

The input must be checked to see whether it represents a permitted LOGO program - it is "parsed". In this case we can develop the parser as a finite automaton³⁸. The unspecified transitions lead to an error state.

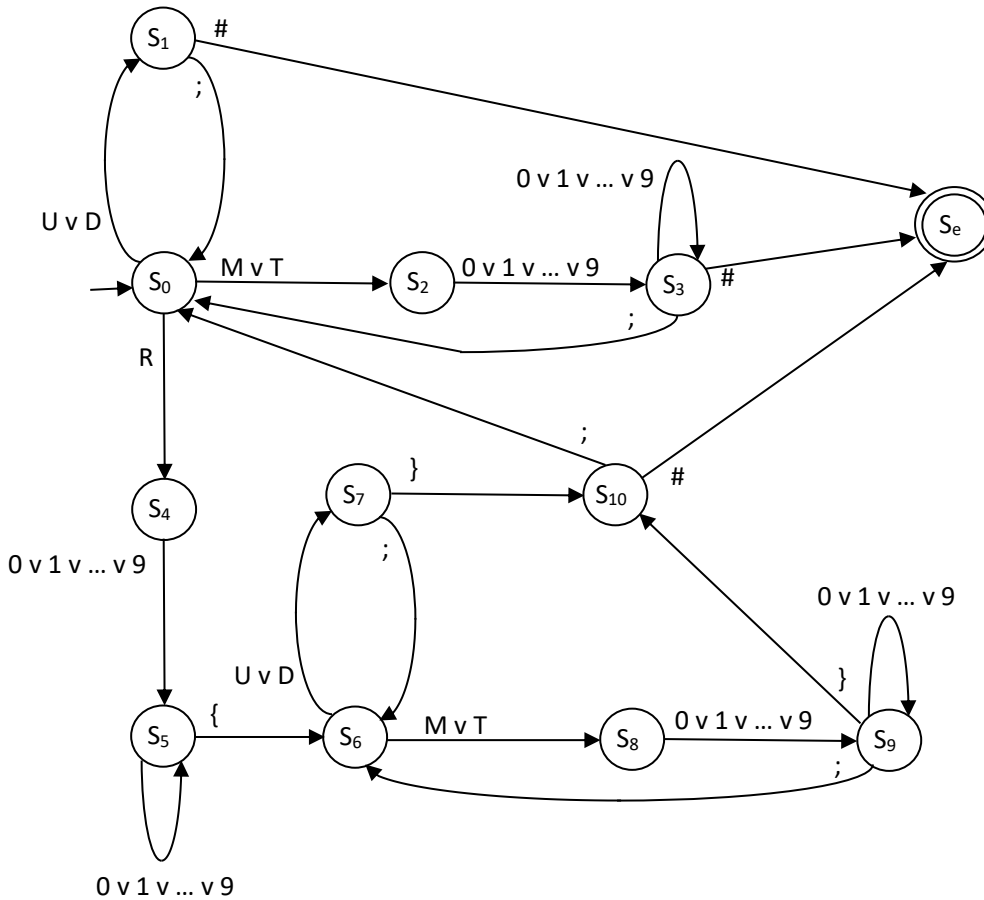

In the individual states we can decide which signs lead to subsequent states and which do not. This allows us to indicate which characters were actually expected in the event of incorrect entries. If we number these error messages of the parser in the order of their occurrence, we get the adjacent table.

If we also evaluate the position of the character in the command where the error occurred, then we can even display the error.

state	possible error message
S_0, S_6	2: unknown command
S_1, S_{10}	3: <,> or <#> expected
S_2, S_4, S_8	4: number expected
S_3	5: number, <,> or <#> expected
S_5	6: number or <{> expected
S_7	7: <,> or <}> expected
S_9	8: Zahl, <,> or <}> expected
	9: unexpected end of input

The translation of the parser consists only of a very long copy of the state graph - of nested alternatives.

³⁸ Why is that, by the way?



The parser *parse* *<program>* is guided through the state diagram by the character string of the program. If there is no permissible transition in a state, it reports the corresponding error by the value of the "result" variable.

Correct programs have the value 0 as a result.

The interpreter *run <program>* can assume that the entered program is error-free - after all it was parsed. Therefore, it can take the first character of the program one after the other - this is the next command - and delete this character. Depending on the command, it executes this and searches for the required parameters, e.g. the angle of rotation. All processed characters are deleted. This ends when the program consists only of the last character – the "#".

```

+ run + program +
script variables command number loop content
repeat until length of program < 2
  set number to 0
  set command to letter 1 of program
  set program to all but first letter of program
  if command = U
    pen up
  else
    if command = D
      pen down
    else
      repeat until letter 1 of program < 0 or letter 1 of program > 9
        set number to 10 * number + unicode of letter 1 of program - unicode of 0
        set program to all but first letter of program
      if command = T
        turn number degrees
      else
        if command = M
          move number steps
        else
          set program to all but first letter of program
          set loop content to #
          repeat until letter 1 of program = #
            set loop content to join loop content letter 1 of program
            set program to all but first letter of program
          set program to all but first letter of program
          repeat number
            run join loop content
  set program to all but first letter of program
  
```

The program is processed character by character, the processed characters are deleted. We used the function *all but first letter of <string>* of the library *words, sentences*.

PenUp command (U)

PenDown command (D)

search for a number

Turn command (T)

Move command (M)

run the loop (R)
Search for loop contents until the next "#"...

... and execute as often as the number indicates. Append a ";" to the loop contents.

If we output the error messages in plain text, then our programming language will slowly become usable.

We can evaluate programs through a short script.

```

go to x: 0 y: 0
point in direction 90
clear
set theProgram to get command
set theResult to parse theProgram
if item 1 of theResult = 0
  run theProgram
else
  show error theResult
    
```

theProgram M100T90#

ERROR: 5 at position5: number, <> or <#> expected

```

+show+ error+ result : +
script variables error text nr
set nr to item 1 of result
if nr = 2
  set error text to unknown-command
if nr = 3
  set error text to <> or <#> expected
if nr = 4
  set error text to number-expected
if nr = 5
  set error text to number,<> or <#> expected
if nr = 6
  set error text to number-or-<> expected
if nr = 7
  set error text to <> or <> expected
if nr = 8
  set error text to number,<> or <> expected
if nr = 9
  set error text to unexpected-end-of-input
say join ERROR: nr at-position item last of result error text
    
```

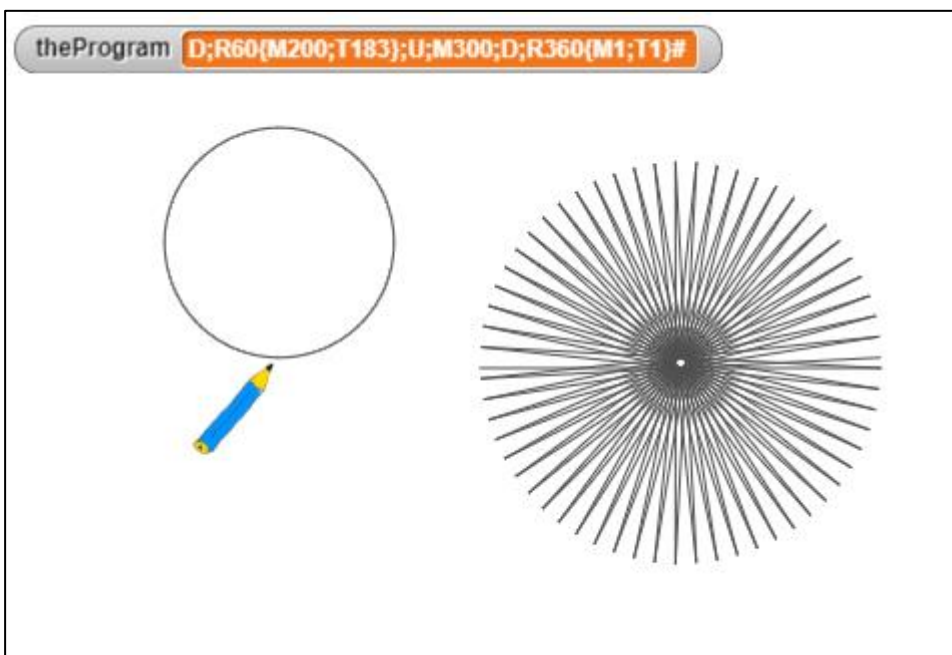

Actually, it is a bit strange to develop a very primitive text-based language in a graphical programming language. However, experience shows that learners usually combine the work of computer scientists with the development of cryptic texts - i.e. they sometimes want to program "really". We can accommodate this wish if we use such a mini-language in a standard field of computer science, in this case automata theory. Since we develop it ourselves, we promote understanding for the processing of texts, which takes place on many levels in IT systems. In addition, we have found a highly differentiating topic suitable for division of work and challenging activities, which quickly leads to presentable results.

Tasks:

1. **Expand** the language **LOGO** by
 - a: a Home (H) command that sends the turtle to the center of the screen.
 - b: a Clear command (C) that clears the screen.
 - c: a Color<n> (Fn) command that allows you to select a pen color.
 - d: a command TurnTo<angle> (Nn), which rotates the Turtle to a certain angle.
 - e: a command MoveTo<x><y> (Vx,y), which sends the turtle to a certain point.
2. Develop a **scanner** that allows you to enter the turtle commands in long form, for example, to write *Turn 90* instead of *T90*. The scanner should recognize these commands and output them again in short form.
3. Introduce an **alternative**: Depending on the color of the pixel at the location of the turtle, it should be possible to execute different command sequences. Reduce the syntax appropriately and implement the command.
4. Two types of **loops** are to be introduced in this way: The turtle should execute drawing commands as long as (*WHILE*) or until (*DO*) the turtle is above pixels of a specified color. Allow position-dependent predicates as well.

16.2 SnapMinder by Jens Mönig³⁹



Contents:

- import and visualization of large amounts of data
- advanced list operations
- connection to socially relevant issues

The program is based on data from the Gapminder Foundation⁴⁰, which provides tools for visualizing statistical data on the Internet. One of these shows the development of the countries in the recent past, whereby life expectancy is represented above income and the size of the "bubbles" corresponds to the total population of the country in one year. If you move the slider, you can impressively follow the temporal development of the countries in this coordinate system.

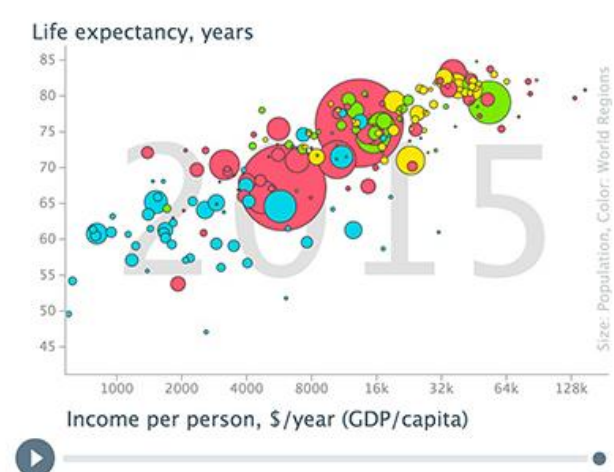

The data used - and many others - can be found in tabular form at <https://www.gapminder.org/data/>

³⁹ With permission of the author, available at snap.berkeley.edu/run#present:Username=jens&ProjectName=SnapMinder

⁴⁰ <https://www.gapminder.org/>

16.2.1 Importing Table Data

To import the required data, we load the file into a spreadsheet program and immediately save it again as a tab-delimited text file. Let us take CO2 emissions per person from 1751 to 2012⁴¹ as an example. For the first years we find only a few values, but then it gets dense.

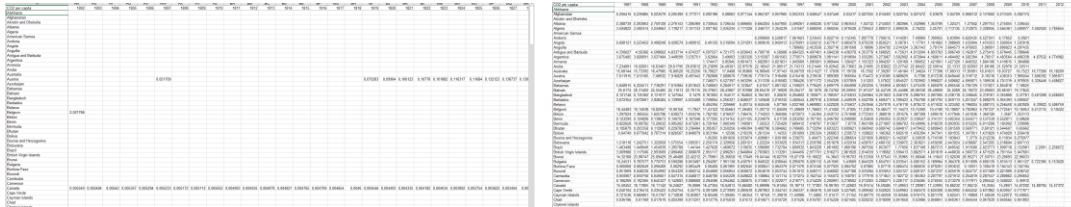

We read the generated text file into a variable via its context menu (*import...*). To do this, it must be displayed in the work area. We get a very long string of characters.



We turn them into a list:



Each line again contains a character string with the data for each country, whereby the data are separated by tabs. Therefore, we "hack" the list line by line in the same way, but with a different separator, and add the sublists to a new list variable called *daten*.

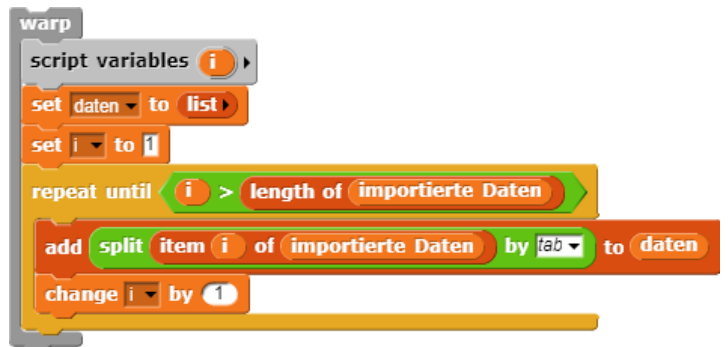

This provides the necessary data for editing in *Snap!*.

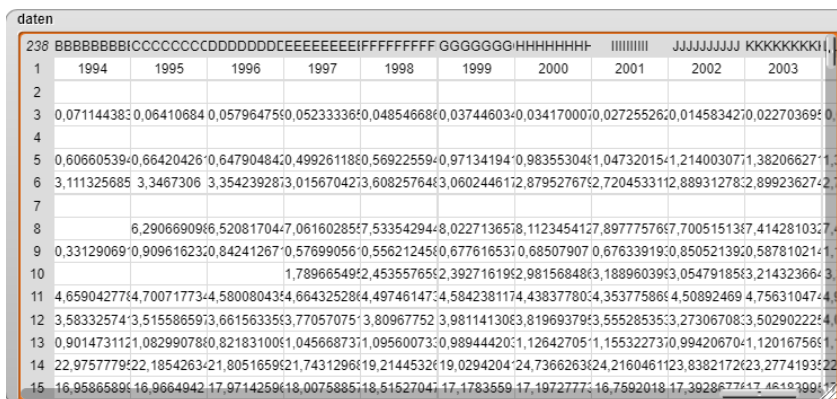

⁴¹ CDIAC: Carbon Dioxide Information Analysis Center

16.2.2 The SnapMinder Data

The program contains the required data as described above in the variables *income data*, *life data* und *population data*.



It prepares them for further use with the help of higher order list operations from the *Tools* library⁴². As an example, we show the population:

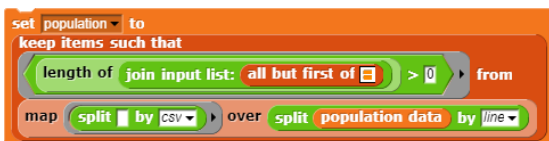

Convert the *population data* into a list (here in "one step") and throw out those "without interesting content".



Use only data from existing countries.

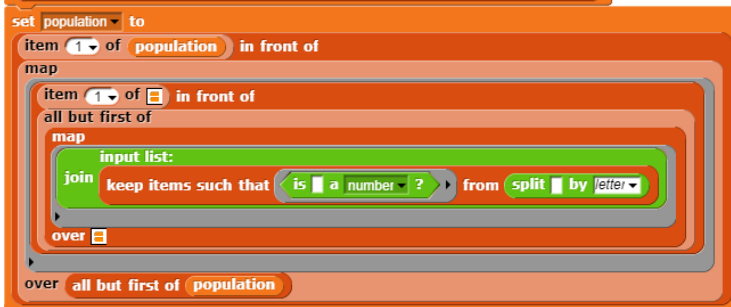

Sort out unusable data ("... no numbers").



Format data separated by commas and with CR between the lines as *population data - clean*.

The operations are very compact due to their nesting. If you take them apart, they are easy to understand. Let's take the first nested block as an example. It can be read "from behind" as:

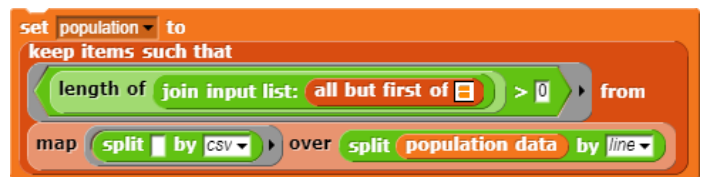

- Split the population data, stored in a string separated by line feeds, into a list. Split this list again. The contents must now be separated by commas (*csv format*).
- Delete from the result all entries where nothing comes after the first entry.
- Assign the result to the variable *population*.

⁴² Jens Mönig uses a little trick: If you move the block of a list operation over the *join* block from the string operations, which is displayed "empty" *join*, i.e. without input parameters, then it turns into the *join input list*-Block *join input list: all but first of*, which converts the list into a simple string. The function can also be easily written by the user.

The program starts with three messages, which cause old country sprites to delete themselves, and the other objects, especially the data lists, to be initialized. For the data, it works like this:

```

when clicked
broadcast remove all and wait
broadcast initialize and wait
broadcast show all
set turbo mode to
    
```

```

when I receive initialize
set income to
keep items such that
length of join input list: all but first of > 0 from
map split by CSV over split income data by line

set life to
keep items such that
length of join input list: all but first of > 0 from
map split by CSV over split life data by line

set countries to map item 1 of over all but first of life

set income to
item 1 of income in front of
keep items such that countries contains item 1 of from
all but first of income

set countries to map item 1 of over all but first of income

set life to
item 1 of life in front of
keep items such that countries contains item 1 of from
all but first of life

set population to
keep items such that
length of join input list: all but first of > 0 from
map split by CSV over split population data - clean by line

set min life to 10
set max life to 90
set max income to 200000
set min population to 0
set max population to 1000000000
set max col to 217

script variables years i idx last found idx
set years to all but first of item 1 of population
set population year index to list

warp
repeat max col
set idx to first index of i + 1800 in years
if idx > 0
set last found idx to idx
add idx to population year index
else
add last found idx to population year index
change i by 1
    
```

Process the data as described above.
First the income, ...

... then life expectancy, ...

... and extract the countries from it.

Assign the income to the countries.

Same for life expectancy.

Write back the population data from the auxiliary variable.

Set some variable values.

Extract the years.

Create a list of years as an index.

16.2.3 The SnapMinder Countries

At the start of the program as many *country* clones, represented by a semi-transparent rectangle, are created as *countries* are included in the country list. Each clone has its own index *idx*.

The main function of the countries is to position themselves in the coordinate system of average income and life expectancy in relation to the year under consideration. For this ...

```

go to data slot slot # + scaling + scaling ? +
script variables dollars years new size
set dollars to item slot of item idx + 1 of income
set years to item slot of item idx + 1 of life
if length of dollars > 1 and length of years > 1
  go to x:
  left +
  log of dollars * 0.003 / log of 2 /
  log of max income * 0.003 / log of 2 * right - left
  y:
  bottom +
  years - min life / max life - min life * top - bottom
  if scaling
    set new size to
    min size +
    sqrt of
    item item value of Slider + 1 of population year index + 1 of
    item idx + 1 of population
    / sqrt of max population
    * max size - min size
    if not new size = size
      set size to new size %
  show
else
  hide
  
```

... they determine these data for their country, ...

... determine the position ...

... and their size, which is given by the population of the country in the year under consideration.

```

when I receive show all
set ghost effect to 60
set size to 50 %
set idx to 1
warp
repeat length of countries - 1
  create a clone of myself
  change idx by 1
broadcast slider changed
  
```

This block is called, among other things, when a plot of the country, i.e. the movement in the coordinate system with the year as parameter, is generated.

```

plot track +
script variables slot
set slot to 3
go to data slot slot scaling
set pen size to 5
pen down
warp
repeat 216
  change slot by 1
  go to data slot slot scaling
pen up
go to data slot value of Slider + 2 scaling
  
```

16.2.4 Use SnapMinder

The presentation is impressive because, on the one hand, the countries move from bottom left to top right in the course of time, i.e. they develop positively. But if you take a closer look at some countries, this development is by no means continuous: there are abrupt downward swings, backward movements, circles, periodic movements,... The program gives rise to research into the causes of these developments, and there are a few surprises! We show plots of some countries, then you should research! 😊



USA



Germany



China



India



Norway



Somalia

16.3 Connectivity: The World is Small⁴³

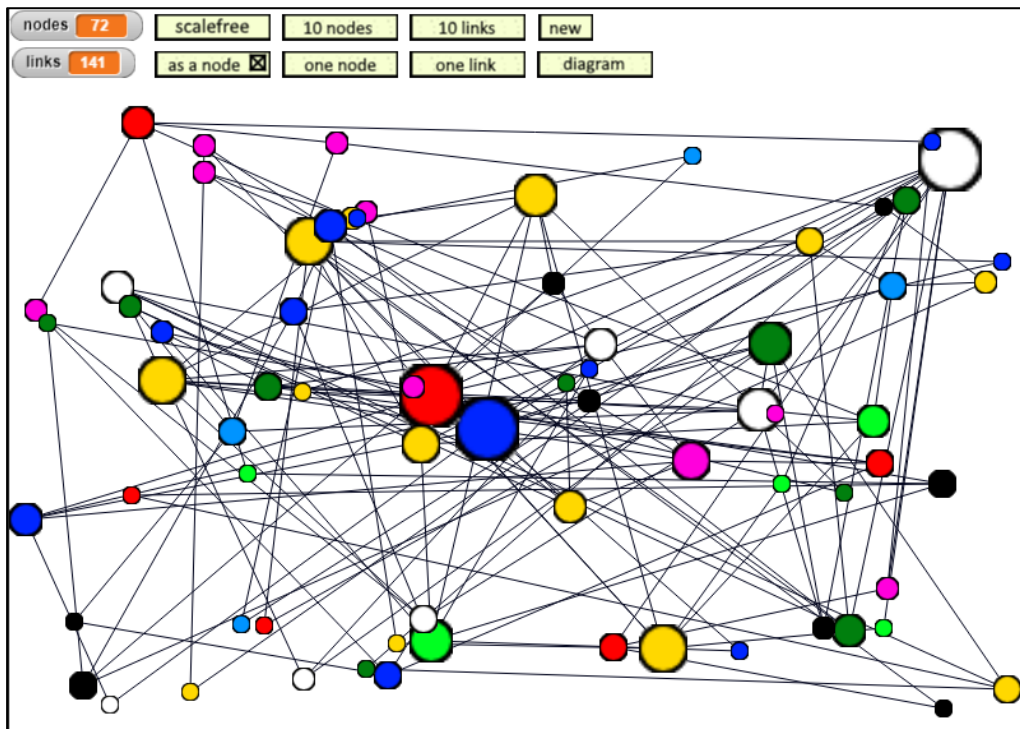

Contents:

1. topology of networks
2. extensive operations on simple lists
3. socially relevant issues

The handling of networks is often reduced to protocols and other technical details. But you can also ask other questions, e.g. about the connection of networks.

- If we have n nodes, how many links do we need for the network to be largely connected?
- Or vice versa: How many and which nodes must be destroyed for a network to break up into its subnets?
- Or: What is the mean distance, counted in links, between the nodes of a network?

Nodes and links can be very different in nature. It can be e.g.

- technical links between computer systems,
- customer/supplier relations in the economy,
- the logical connections via linked websites,
- social relations between persons or groups of persons
- hydrogen bonds in organic compounds,
- neuronal networks
- or infection chains.

⁴³ from: E. Modrow: Informatik mit Delphi – Band 2, emu-online, 2003

16.3.1 Random Networks

The starting point for such questions were *Random Networks*. They are created when we build N network nodes (or pages, ...) that we subsequently link to each other. Let us take the Internet as an example. If there are N pages with on average k links per page, then with n mouse-clicks k^n pages are accessible. We can reach virtually any page if it is: $k^n = N \rightarrow n = \log N / \log k$. With 5 billion pages and $k = 7$, $n = 11.5$, i.e.: with about 12 mouse clicks on average, you can visit any page of this network. Similar considerations and practical studies have been carried out on social relations, etc. They can be found under the name *Small World Phenomenon*⁴⁴.

If you display the distribution of links per page, you get a *Poisson distribution* for Random Networks.

It is somewhat more difficult to decide whether a network is (largely) coherent, i.e. whether all nodes are connected to each other. We can answer this question by coloring: start with one node and color all the nodes that can be reached by it in the same color, then a coherent network shows a kind of phase transition: almost suddenly all nodes take on the same color.

You can see that the network - with the exception of a few slips - is coherent if the number of links roughly corresponds to the number of nodes. Further links do little to change.

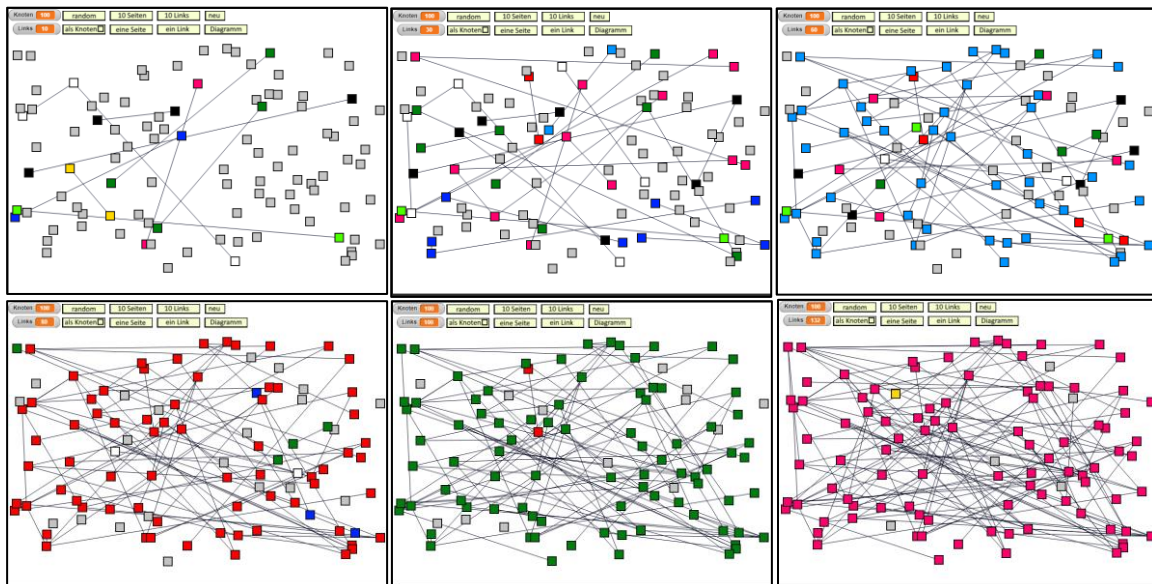
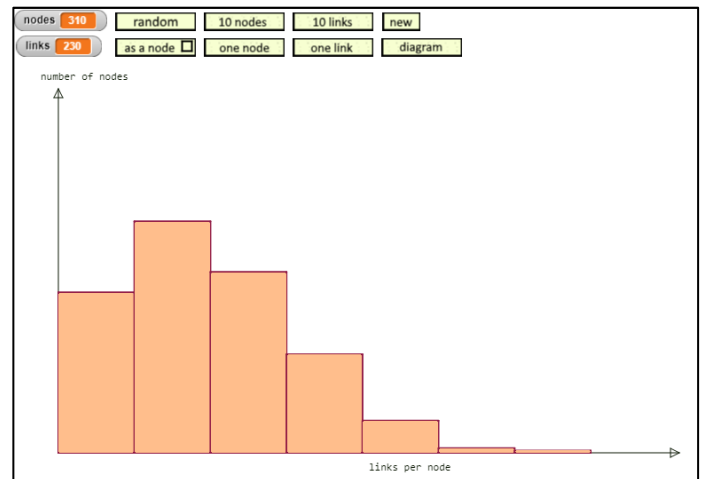

⁴⁴ <https://de.wikipedia.org/wiki/Kleine-Welt-Ph%C3%A4nomen>

16.3.2 Scalefree Networks

Albert-László Barabási⁴⁵ showed in 2002 that growing networks like the Internet have a different distribution of links per node than Random Networks. It can be described by a *Pareto distribution*. Brief descriptions can be found under

<http://barabasi.com/f/623.pdf> or

<http://barabasi.com/f/624.pdf>.

A *Scalefree network* can be created by alternately adding nodes and links where the new nodes have two links to existing nodes. The older nodes are more likely to be linked than the younger nodes. Because the network is always coherent, there is no need to color contiguous nodes. But we want to make the size of the nodes dependent on the number of their links.

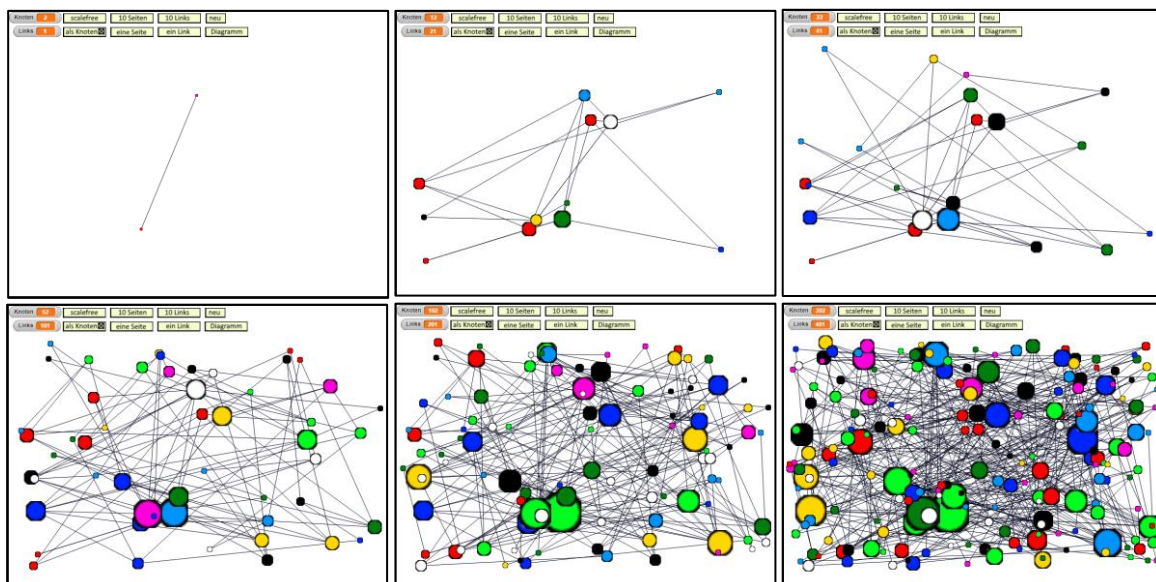
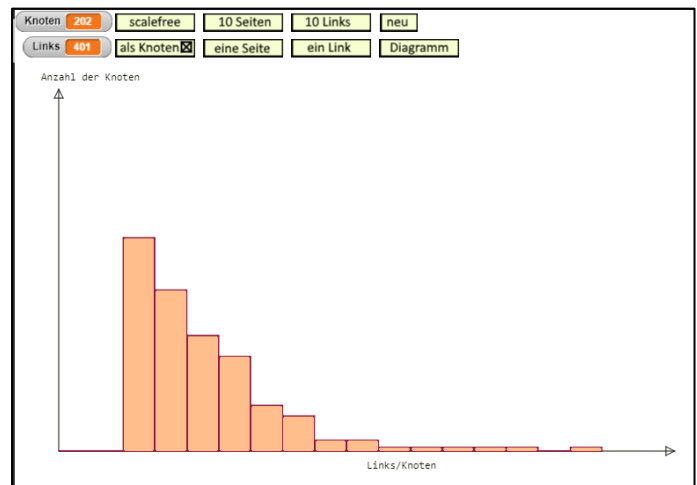

Scalefree networks are the same on all scales, i.e. numerous nodes with few connections are connected to a few nodes with many connections, so-called *hubs*. The connections between nodes normally run from the start node to the next hub, then via a few more hubs to the target node. Hubs can be, for example, people with many contacts (teachers, representatives, ...), central computers or distribution centers in merchandise management.

Scalefree Networks are extremely robust against technical faults. For example, if a network connection happens to fail, it probably does not affect a hub, and if it does, other hubs will compensate this. However, they are also extremely susceptible to targeted interference. If only a few hubs in this network type are destroyed, the network disintegrates into its individual parts.

⁴⁵ A.Barabási: Linked: the new science of networks, Perseus Publishing 2002

The topic is suitable as an introduction to discussions about vaccination protection, preventing the spread of diseases, influencing political opinion-forming, optimizing the flow of goods, ...

16.3.3 The Implementation

We want to create a fairly simple model as a tool for researching network properties. It is essentially based on a *node* from which clones are generated and two lists, of which the *node list* contains the nodes already generated and the *link list* consists of sub-lists with the numbers of the two end nodes of the links. With their help, methods can be implemented largely independently of each other. They are used by the operating elements shown. The controls depend on the selected net type (*random/scalefree*) and the display of the nodes (*rectangular/round with different sizes*).

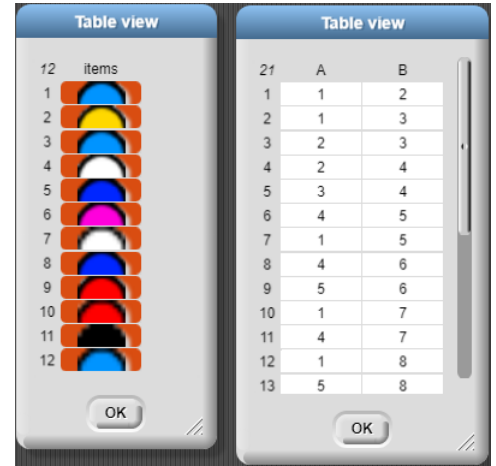

node list and link list

```

when I am clicked
  if costume name of bTypeOfNetwork = bRandom
    switch to costume bScalefree
    set type of network to scalefree
    broadcast delete all
    broadcast new
    wait 0.1 secs
    create two linked nodes
  else
    switch to costume bRandom
    set type of network to random
    broadcast delete all
    broadcast new
    
```

Buttons for switching between net types or for creating 10 nodes react to mouse clicks:

```

when I am clicked
  warp
  if type of network = random
    repeat 10
      add ask Node for new node of Node to nodelist
      change nodes by 1
  else
    repeat 10
      create a new scalefree node
      show all nodes
    
```

Since we often have to iterate over such node lists, we introduce a new control structure that executes an instruction for all objects in a list:

```

+ tell all objects of list : to do this λ +
script variables i
set i to 1
repeat until i > length of list
  tell item i of list to do this
  change i by 1
    
```

This makes it very easy, for example, to display all nodes:

```

+ show all nodes +
warp
script variables i
create links per node Links pro Knoten
tell all objects of nodelist to show of Node
    
```

New nodes are created by cloning the prototype. The prototype can be asked to perform this action.

```
ask Node for new node of Node
```

```
+new +node+
script variables new
change index by 1
go to x: pick random -390 to 390 y: pick random -250 to 220
if costume round
  switch to costume circle gray
  set size to 30 %
else
  switch to costume square gray
  set size to 100 %
show
set new to a new clone of myself
run set index to of new with inputs index
hide
report new
```

A new link is inserted into the network by trying to find two nodes that are not yet connected. The link list must then be searched to see if the link already exists. If not, the search returns 0.

This allows the ends of the link to be determined. Since the resulting nets are quickly becoming large, the search for them does not take too long.

```
+insert +a +link+
script variables node1 node2 costume no n1 n2 i found
warp
set found to false
if length of nodelist > 1
  set n1 to pick random 1 to length of nodelist
  set n2 to pick random 1 to length of nodelist
  set i to 1
  repeat until i > 2 or found
    set n2 to pick random 1 to length of nodelist
    set found to not n1 = n2 and
      index of list n1 n2 in linklist = 0 and
      index of list n2 n1 in linklist = 0
    change i by 1
  if found
    insert a link from n1 to n2
```

```
+index +of +element +in +list+
warp
script variables i index
set index to 0
set i to 1
repeat until i > length of list
  if item i of list = element
    set index to i
  change i by 1
report index
```

Once you know which nodes are to be connected from a link, ...

... then the affected nodes are searched for, ...

... the costume according to the net type is selected, and the knots are asked to change to it.

The pen is asked to draw a line between the nodes.

Finally, the new link is entered in the link list and the related nodes are colored in the same way.

With Scalefree Networks it is a bit easier, because the costumes are chosen randomly.

```

+ insert + a + link + from + n1 # + to + n2 # +
warp
script variables node1 node2 costume no
set node1 to item n1 of nodelist
set node2 to item n2 of nodelist
if type of network = random
  if
    costume # of node1 > 11 and costume # of node1 < 11 or
    costume # of node1 > 11 and costume # of node1 < 21
    set costume no to costume # of node1
    tell node2 to switch to costume with inputs costume no
  else
    if costume round
      set costume no to pick random 12 to 20
    else
      set costume no to pick random 2 to 10
    tell node1 to switch to costume with inputs costume no
    tell node2 to switch to costume with inputs costume no
  tell Pen to draw a line from to of Pen
  with inputs node1 node2
  insert list n1 n2 in linklist
  color nodes connected to n1
else
  if costume round
    tell node1 to switch to costume with inputs pick random 12 to 20
    tell node2 to switch to costume with inputs pick random 12 to 20
  else
    tell node1 to switch to costume with inputs pick random 2 to 10
    tell node2 to switch to costume with inputs pick random 2 to 10
  tell Pen to draw a line from to of Pen
  with inputs node1 node2
  insert list n1 n2 in linklist

```

The most complex part is the coloring of the connected subnets. We work with two lists, from which the *connected nodes* get all nodes that can be reached from the starting node. The *nodes to be colored* contain the nodes that have to be colored – sic.

We start with the given node number as the beginning and remember its costume.

As long as there are still nodes in the list, we examine the link list to see if the first node number of the connected nodes appears in the link either to the left or right. If so, the other node is also connected to the source node and is added to the list if it is not already in the list.

If the first node in the list is not yet contained in the list *nodes to be colored*, it is entered there and removed from the list of *connected nodes*.

Finally, the costumes of all nodes to be colored are set to the same value as the costume number of the initial node.

```

+ color + nodes + connected + to + node no # +
script variables
connected nodes  nodes to be colored  costume no  i  link
warp
set nodes to be colored to list
set connected nodes to list node no
set costume no to costume # of item node no of nodelist
repeat until length of connected nodes = 0
  set i to 1
  repeat until i > length of linklist
    set link to item i of linklist
    if item 1 of link = item 1 of connected nodes and
      index of item 2 of link in nodes to be colored =
        nodes to be colored
      add item 2 of link to connected nodes
    else
      if item 2 of link = item 1 of connected nodes and
        index of item 1 of link in nodes to be colored = 0
        add item 1 of link to connected nodes
    change i by 1
  if index of item 1 of connected nodes in nodes to be colored = 0
    add item 1 of connected nodes to nodes to be colored
    delete 1 of connected nodes
  set i to 1
  repeat until i > length of nodes to be colored
    tell item item i of nodes to be colored of nodelist to
      switch to costume with inputs costume no
    change i by 1
  
```

The controls, the two (and further) net types, the creation, joining and coloring of nodes as well as the diagram creation are based on the sub-lists and can be developed largely independently of each other. The topic is therefore well suited for teaching in different working groups.

16.4 Evolution

Contents:

- simple event control with buttons
- easy access to objects
- simple use of lists

The aim of this small project is to produce a presentable result with the simplest possible methods, which can be used in class if required. The methods, e.g. for the representation of the animals, are partly found by "trial and error", which of course challenges improvements. That's the way it's supposed to be. The starting points of the parts are somewhat highlighted in the pictures.

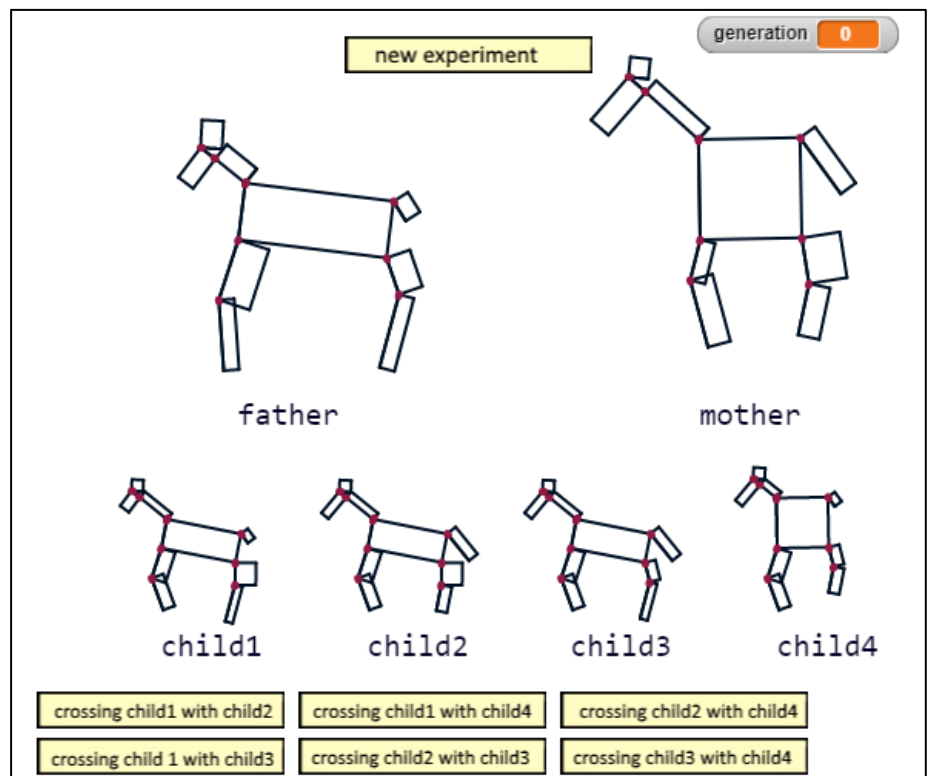

In the project, "animals" are randomly created, each consisting of 9 rectangles of random size, which are rotated to create a kind of horse. With a different composition, other "animals" can be quickly produced. The partial rectangles are always drawn in the same order and orientation, so that you have to try out where to start drawing. Of course, this problem can be solved more elegantly with some mathematics, and if parameters can be used to influence how a rectangle is drawn, then it can be done more beautifully - in a different way. But it can also be done quite simply.

After the production of two animals, four offspring are created and shown slightly smaller below. From these you can choose two and appoint them as new parents. If you repeat this, you can "breed out" certain characteristics, e.g. small heads or short legs. At each crossing, the characteristics are changed at random. If a part becomes too small, it falls away. So you can breed something like seals or ostriches out of the initial horses.

It makes sense to create new parts by mutations or to change the starting point of the parts, i.e. to let them "migrate". To do this, the data structures must be changed, for example by recording the coordinates of the approach points and adjusting the methods accordingly.

New animals can be created from the object *Animal*, which has a local method for this. In it, the parts of the animal are generated as lists of "reasonably usable" random numbers. They are then combined to form the complete list.

The parts of the animals are always drawn with the same method *show part*. The pen moves to the horizontal position and rotates to the angle passed as the third element in the list, then draws a rectangle with the lengths passed as the first and second element. In addition, the starting point is emphasized somewhat.

The method *show animal* first changes the size of the animal as indicated. Then the parts are drawn at the "tried out" points. Only the first part of it is shown.

The script for `show animal` starts with a comment `+show+ animal+ animal : +at+ x # + y # +size+ n # +`. It uses script variables `ear`, `head`, `neck`, `body`, and `display`. The process begins by changing the size of the animal to `n`. Then, it sets the `ear`, `head`, `neck`, and `body` variables to items 1, 2, 3, and 4 of the `display` list, respectively. The script then moves to coordinates `x` and `y` and shows the `body` part. It then draws the `neck` part by moving the pen to the start of the neck, turning 90 degrees, and drawing a rectangle with the first two items of the neck list. Next, it draws the `head` part by moving the pen to the start of the head, turning 90 degrees, and drawing a rectangle with the first two items of the head list. Finally, it draws the `ear` part by moving the pen to the start of the ear, turning 90 degrees, and drawing a rectangle with the first two items of the ear list. The script concludes by showing the animal at coordinates `x` and `y` with sizes 2 and 3.

The script for `new animal` starts with a comment `+new+ animal+` and uses script variables `head`, `ear`, `neck`, `body`, `frontLegUp`, `frontLegDown`, `hindLegUp`, `hindLegDown`, and `tail`. It sets each variable to a list of random numbers: `head` (two lists), `ear` (two lists), `neck` (two lists), `body` (two lists), `frontLegUp` (two lists), `frontLegDown` (two lists), `hindLegUp` (two lists), `hindLegDown` (two lists), and `tail` (two lists). The script ends with a `report` block listing all these variables.

The script for `show part` starts with a comment `+show+ part+ part :`. It begins by setting the pen size to 2 and the pen color to black. It then moves the pen to the start of the part, turns 90 degrees, and draws a rectangle with the first two items of the part list. Next, it turns 90 degrees and draws a rectangle with the first two items of the part list. Then, it turns 180 degrees and draws a rectangle with the first two items of the part list. Finally, it turns 180 degrees, moves the pen 1 step, sets the pen size to 5 and the pen color to red, moves the pen 1 step, and ends with the pen up.

Two animals are "crossed" by randomly assembling the parts of one or the other animal into a new one. During each of these processes the dimensions are changed randomly - depending on the mutation rate *mr*.

Select from which animal a part will be taken.

Change the width of the part at random.

Too small parts fall away.

also, for the height

Add part to new animal.

Return result.

```

+ crossing of + animal1 : + with + animal2 : + mutation rate + mr # + % +
script variables part i result
set result to list
set i to 1
repeat 9
  if pick random 1 to 2 = 1
    set part to item i of animal1
  else
    set part to item i of animal2
  if
    pick random 0 to 100 < mr and item 1 of part > 0
    replace item 1 of part with
      item 1 of part + pick random -2 to 2
    if item 1 of part < 2
      replace item 1 of part with 0
      replace item 2 of part with 0
  if
    pick random 0 to 100 < mr and item 2 of part > 0
    replace item 2 of part with
      item 2 of part + pick random -2 to 2
    if item 2 of part < 2
      replace item 1 of part with 0
      replace item 2 of part with 0
  if pick random 0 to 100 < mr
    replace item 3 of part with
      item 3 of part + pick random -5 to 5
  add part to result
  change i by 1
report result
    
```

A new experiment is started by asking the *Animal* object to create two new animals as *father* and *mother*. They'll be crossed.

```

+ new + experiment +
set father to ask Animal for new animal of Animal
set mother to ask Animal for new animal of Animal
crossing of father with mother
set generation to 0
    
```

This is done accordingly with the children.

```

when I am clicked
  crossing of child1 with child2
  go to x: -200 y: -205
  change generation by 1
    
```

Let us try to breed "jumping ponies" with short tails. First we create the parents and select candidates for ponies from the offspring.

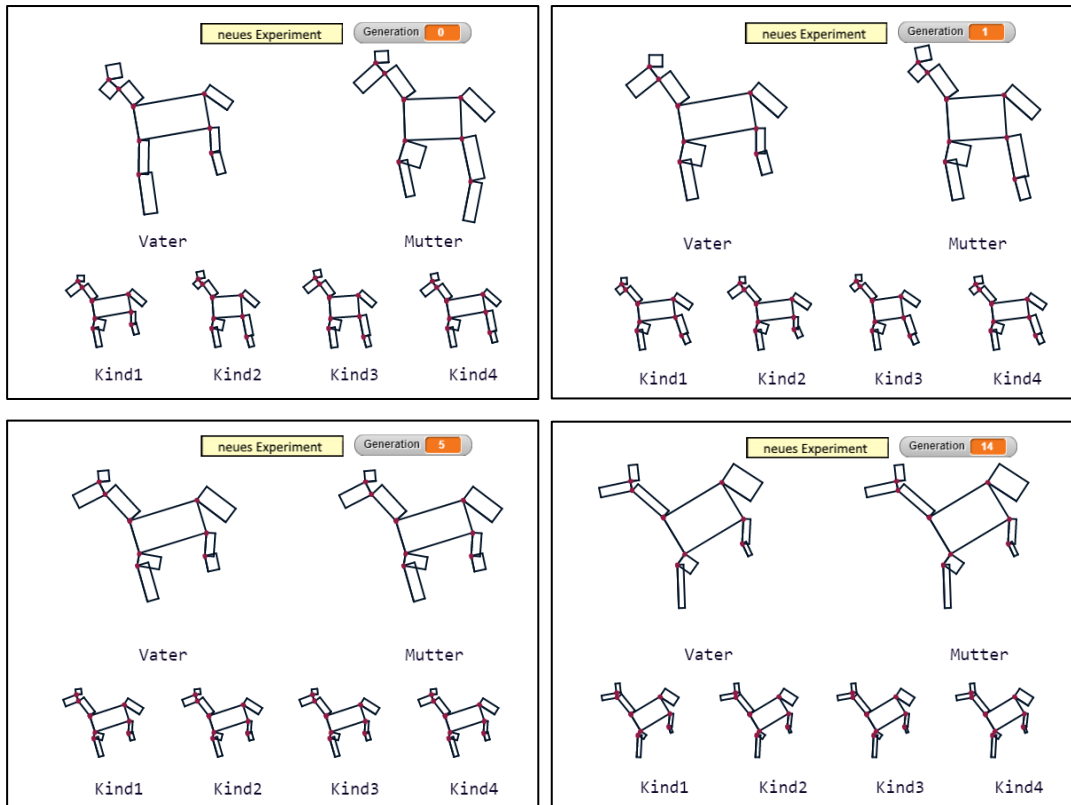

Well - evolution is just unfathomable! 😊

16.5 Using the Sensor Board Calliope

Contents:

- access to external hardware
- physical computing
- access to current topics (“smart watch”)

We use one of the standard sensor boards, in this case the *Calliope mini*. For this, there is a program by Andreas Flemming⁴⁶, which continuously sends the measured values of the board via an internal server and thus also makes them accessible to browser applications via the http protocol. If we start the program, the Calliope board is found after a short search and the measured values are displayed.

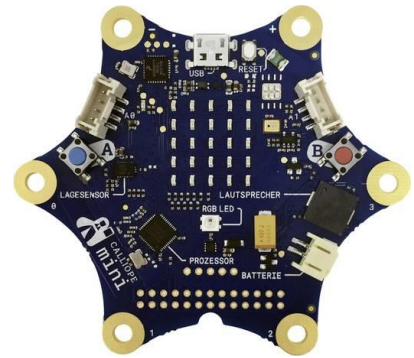
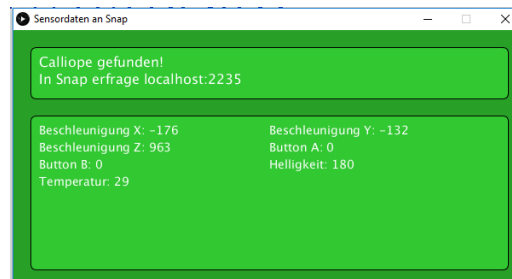

The measured values are in the sequence *acceleration in x-, -y and z-direction*, state of buttons *A* and *B* as well as *brightness* and *temperature*, each in free units. We can easily split this string. Afterwards the individual values are accessible as contents of a list.

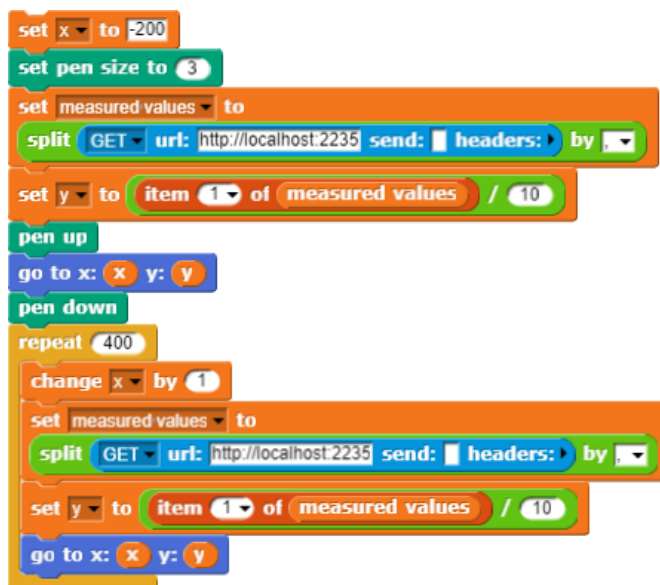

In a small script, based on an idea by Annika Eickhoff-Schachtebeck⁴⁷, we try to convert the acceleration sensor in the x-direction into a step counter, as it is used in smart watches. We therefore attach the sensor board to the arm or leg and display the measured values graphically. (However, we should have a long enough cable between board and computer!)

The Calliope board as a pedometer.

⁴⁶ <https://www.uni-goettingen.de/de/software+zur+verwendung+des+calliope+mini+mit+scratch+1.4%2c+byob+und+snap%21+%28andreas+flemming%29+download/569672.html>

⁴⁷ in <https://www.uni-goettingen.de/de/unterrichtsbeispiel+fitnessarmband+%28dr.+annika+eickhoff-schachtebeck%29+download/565581.html>

The result is graphically available here, but can of course also be stored and evaluated as a series of measured values.

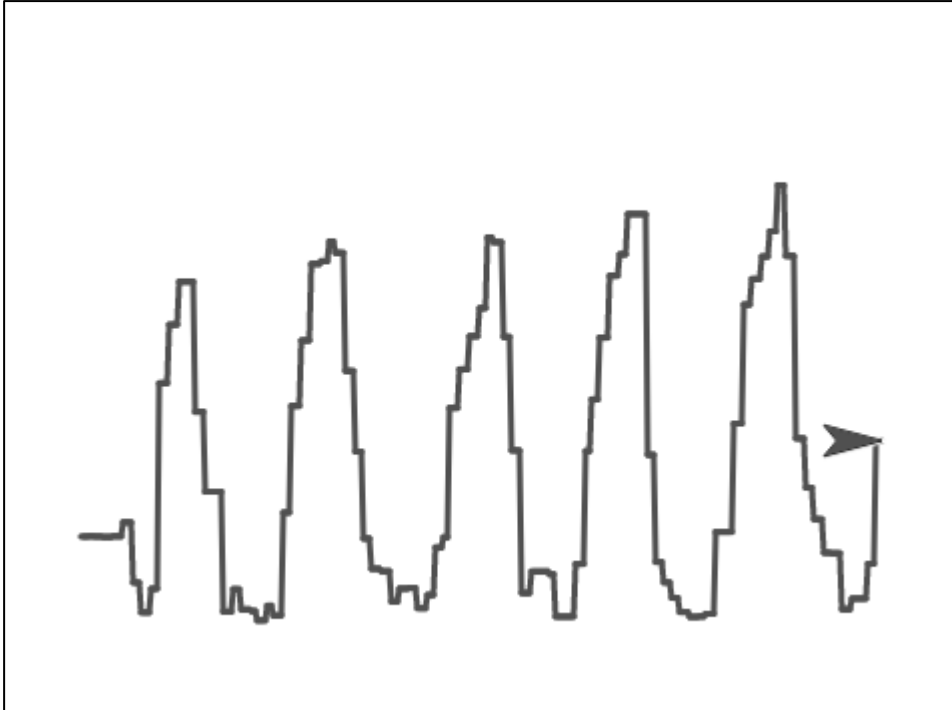

As an example, we enter the x-acceleration and the corresponding time of the measurement to a list.



These data must be smoothed for an evaluation, e.g. using an averaging of adjacent values, and then the maxima of the measurement series can be determined for a step count. Both are nice detail tasks. If we assume an average step size of 1m, then we can also determine the speed - and display the results. These can then be easily compared with those of commercially available devices. They're often no better. 😊



16.6 Rate Websites: PageRank⁴⁸

Contents:

- search engines
- OOP techniques
- current political issues

If you know the addresses of websites, you can reach them directly via the net. But what happens when we search for pages with specific content? For this purpose, of course we use the search engines, which propose us to certain keywords network addresses from their tables of contents. These directories can be created by web crawlers automatically visiting as many accessible websites as possible, jumping from link to link, and adding the keywords found there to the table of contents of the search engine. This usually results in extremely extensive address collections for the same keyword.

Since users of search engines cannot handle large unordered address collections, the pages found for a keyword must be sorted according to their importance. Users then usually use relatively few addresses that appear first. The links below are hardly noticed. So at least the commercially operating providers on the net must be interested in appearing as high up as possible in the lists created by search engines in order to be found by potential customers at all. They use all tricks to achieve this.

So far, nothing has been said about the meaning of a page's information for the keyword. Just showing up doesn't mean much. For example, if a page contains the text "*Nothing is written here about Göttingen*", it will still be included in the table of contents relating to the keyword "Göttingen". So, we need other evaluation criteria. In the simplest case, the authors of a web page enter keywords in the meta tags for the content of the page:

```
<meta name = "keywords" content = "Snap!, school, computer science">
```

However, this possibility is often abused by using frequently used keywords - which do not affect the page content at all - to direct potential "victims" to the site. Not very helpful is the idea to count how often the keyword appears on the page. In this case, web pages sometimes contain certain keywords "invisible", e.g. by writing the keyword very often in white on a white background. Of course, you can also have people rate websites and enter them in the search directories. But this is a very expensive and relatively slow way to create directories, and of course such an evaluation is subjective. It is also often difficult to evaluate pages with special content - e.g. from archaeology. In the worst case, the "value" of a page does not result from its content, but from the amount paid for the evaluation.

Another way to use the expertise of web authors for the evaluation of web pages on the one hand and to automate the evaluation process on the other hand is realized in the so-called *PageRank* procedure. Unlike the meta tags that evaluate your own website, links from one website to other websites are seen as a knowledge-based vote by which authors indicate that other websites contain interesting content. If someone refers to a page with physical content, the author will most likely understand something about the content.

⁴⁸ from: E. Modrow: Technische Informatik mit Delphi, emu-online, 2004

Moreover, since it is usually not known which other websites refer to their own, web authors can only manipulate this procedure with difficulty.

The PageRank method does not evaluate all links equally. It determines a rank (the PageRank) for each known website, which describes the "weight" of this page. This rank is divided during the "vote" by links to all references leading away from the page. If a web page contains only one outbound link, then this receives the entire weight of the page, if it contains two, the weight is halved, and so on. (If the page does not contain an outgoing link, it will not take part in the vote. In the PageRank calculation, it returns the value 0.) The rank of a website increases if as many high ranked pages as possible refer to it and if these pages contain as few links as possible.

As a first example, let's choose two pages that mutually refer to each other. To calculate the PageRank of page A - $PR(A)$ - we need the PageRank $PR(B)$ of page B , because a link from B leads to page A . The calculation of $PR(B)$, however, again includes $PR(A)$. So, we need an old value of $PR(A)$

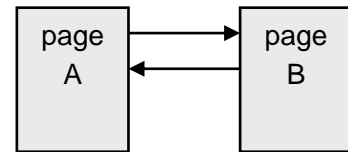

to determine the new one. Since this argumentation can be continued, a method must be developed to reduce the influence of the old values on the calculation of the new rank, so that a stable result is obtained in the course of the calculations. This is achieved by multiplying the contribution of the incoming links by a factor d which is less than 1. Since this is included in every calculation, the "very old" PageRanks are multiplied by d^n , a number that is increasingly approaching zero. For example, you select the value 0.85 for d . If we designate the times at which the PageRank was calculated in the past as t_1, t_2, t_3, \dots , whereby a larger index should mean an earlier time, then for both our web pages we get:

$$PR_{t_1}(A) = \dots + 0,85 \cdot PR_{t_2}(B) = \dots + 0,85 \cdot (\dots + 0,85 \cdot PR_{t_3}(A)) = \dots + 0,85 \cdot \dots + 0,85^2 \cdot PR_{t_3}(A) = \dots$$

If page B had more than one outbound link, we would have to divide its rank in the calculation by the number of links - $C(B)$. We must proceed accordingly with the other sites that have links to page A . If we call these n web pages T_1, T_2, \dots, T_n and replace the three dots in the above relationship with $(1-d)$, then we get the original formula that was initially given by Google for the page rank calculation:

$$PR(A) = (1-d) + d \cdot \left(\frac{PR(T_1)}{C(T_1)} + \frac{PR(T_2)}{C(T_2)} + \dots + \frac{PR(T_n)}{C(T_n)} \right), \quad d = 0,85$$

The rank of a website is at least 0.15 . But what influence do the other terms have? We want to clarify the question with a simulation program in which symbolic web pages can be created and linked. The PageRanks can be calculated in a "website" created in this way.

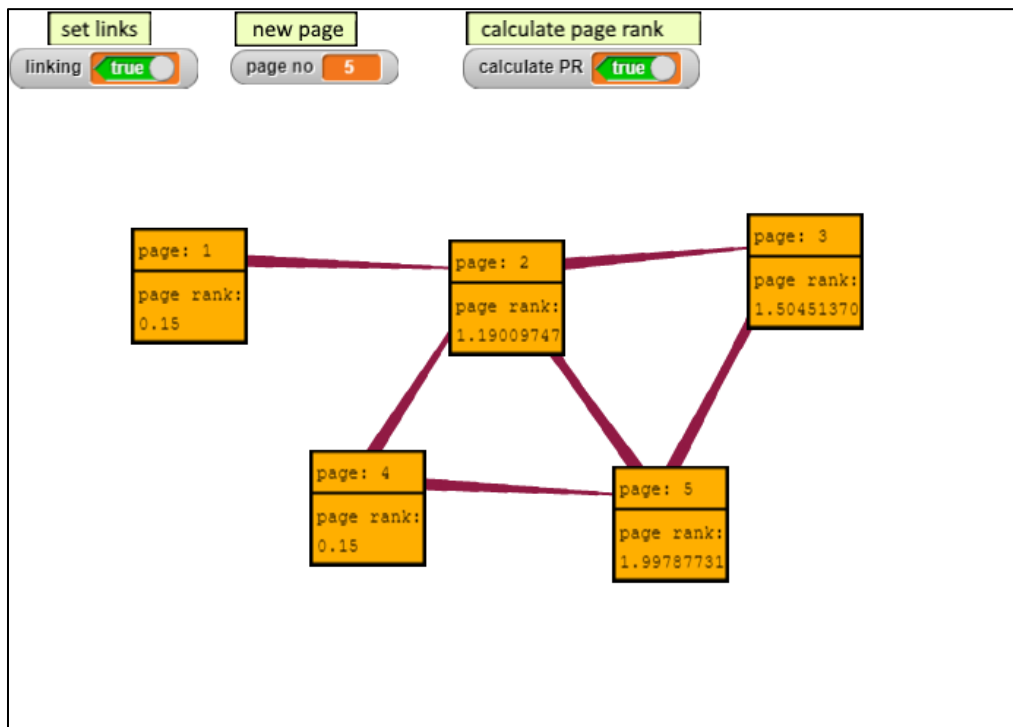

In our program, in addition to the buttons shown, which serve to control the functionality, we need the prototype of a "Page", which (here) should be a website, as well as a global list of all generated pages. Each page contains a *link list* with the numbers of the linked pages, a *number*, a PageRank *PR* and a help variable *PRnew*, in which the newly calculated PageRank is added up.

Pages can be displayed on the screen. Since text and numerical values as well as some lines are to be drawn here, we use the already developed graphics library.

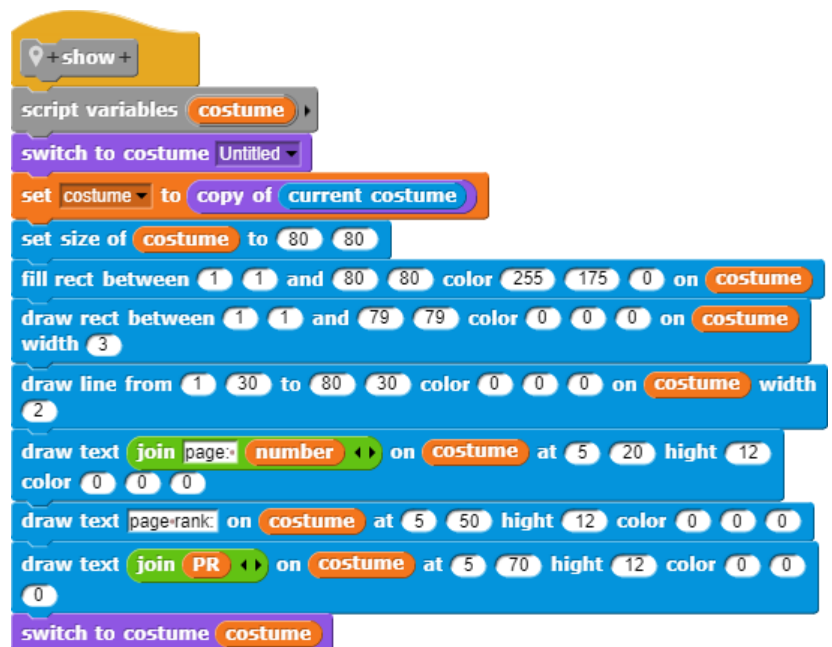

The most important task of the prototype is to create clones of itself. We save such a clone in a script variable *result* and ask it to perform the operations that produce the desired result through a sequence of commands. The generated page is added to the *page list*.



In the corresponding mode, pages are connected by clicking on two pages in succession. The numbers of the affected pages are stored in two global variables. Then the first one can be asked to "link" to the second one. The *Pen* draws a line between the sides that decreases in thickness, a kind of arrow. (Mutually connected sides thus maintain a connection almost the same thickness.) The second page is inserted into the link list of the first page.

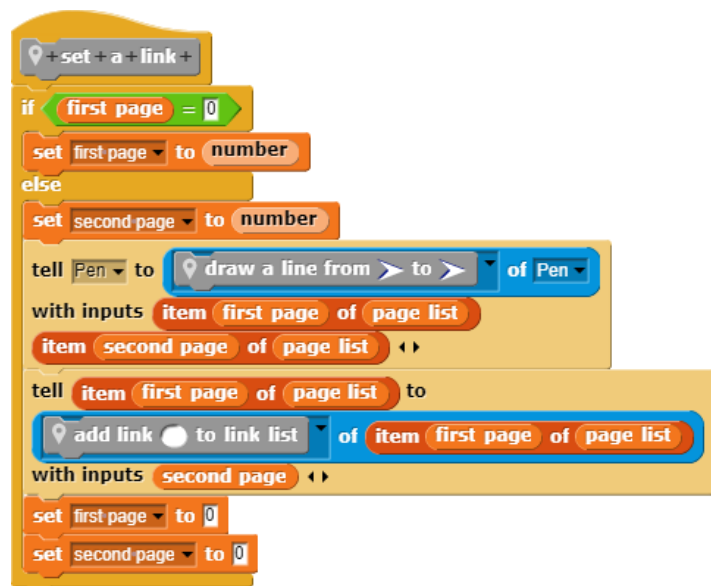

When recalculating the PageRanks, each page must distribute its current *value* to all connected pages. The page calculates this value and asks all pages of the link list to increase their auxiliary value *PRnew* accordingly.

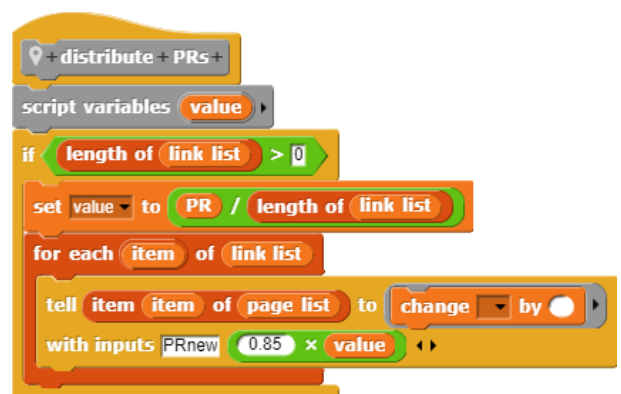

You can use these auxiliary methods to calculate the pageranks. First of all, all auxiliary variables of the involved pages are set to zero. Then all pages distribute their values to the connected other pages. When this is done, the auxiliary variables are copied into the PR variables and the pages are redrawn with the new values.

```

+ calculate + all + PRs +
script variables i
set i to 1
repeat until i > length of page list
  delete all PRs
  tell item i of page list to set to 0 with inputs PRnew 0.15
  change i by 1
set i to 1
repeat until i > length of page list
  calculate new PRs
  tell item i of page list to distribute PRs of Page
  change i by 1
set i to 1
repeat until i > length of page list
  transfer PRs
  tell item i of page list to set to PRnew of item i of page list
  change i by 1
set i to 1
repeat until i > length of page list
  show pages
  change i by 1
  
```

We now want to use our simulation program. We create two websites, link them and calculate the PageRanks. You can see that the values converge towards 1 (independent of the initial PageRank, by the way). This is of course no surprise, because this is exactly what we intended to achieve with the introduction of the "damping factor" of 0.85.

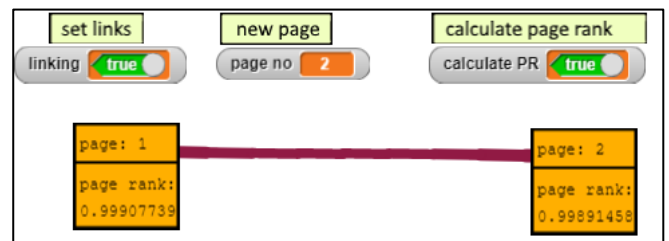

As next example we choose the structure of a typical homepage with a tree structure, which starts from an index page and branches to subdirectories.

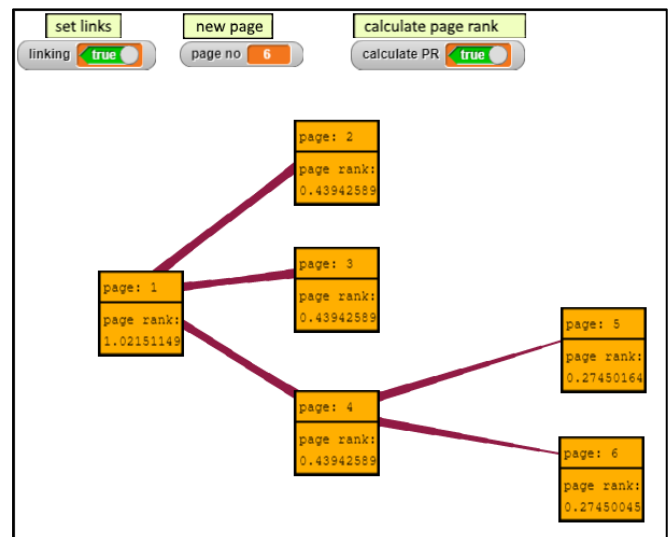

We now assume that there are additional external sites that link to our homepage.

The PageRank of the homepage increases considerably, also the weight of the internal pages increases.

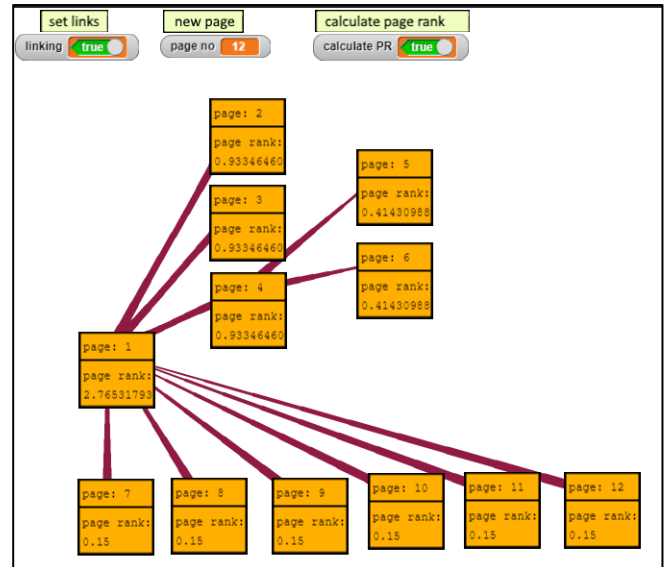

Finally, we want to assume that the external pages are again referenced in a link list of the homepage.

The rank of the homepage continues to rise. One can see how the importance of the pages is growing in a network of pages that mutually refer to one another in order to express their "respect" for one another.

The PageRank procedure is a technical process that can also be transferred to other, e.g. social systems. However, it quickly leads to socio-political questions, because the focus is not on the content of the pages, but on their structure and functionality.

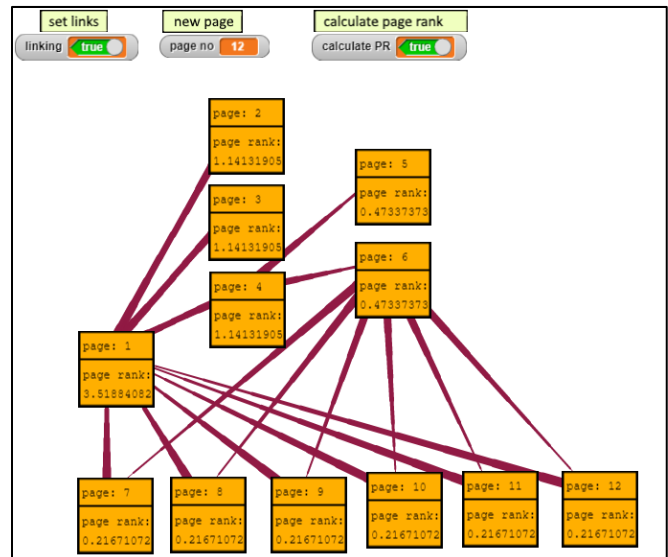

1. If the result of the PageRank calculation is decisive for the "visibility" of the pages⁴⁹, why are commercially oriented private companies allowed to decide on this visibility?
2. The intelligence of the system results from the expertise of those who have consciously set links in very different areas. Isn't the result actually a public good that should be available to everyone without some profit (and power) from it?
3. If only the PageRank would be decisive, the search results would always have to be arranged in the same order. Obviously, this is not the case: the results differ depending on the person who is looking for. They are filtered according to their interests assumed by the search engine. In extreme cases, you only get the results that you want to see - or that someone thinks you want to see - or that someone thinks you should see. The political consequences (keyword: "echo chambers") are currently under discussion.

⁴⁹ What only appears at the back is practically non-existent on the net.

17 At the Supermarket⁵⁰

In the following, rather extensive project we will work in different groups in the same context: a supermarket. On the one hand, technical questions are clarified and "specialist" methods are applied, and on the other hand, these questions are intended to give rise, for example, to the social effects of the technology used. The aim is to show that a system that is only one-sidedly geared towards the "automation" of its tasks can get pretty out of control. The conflicts of interest that arise between the supermarket on the one hand, whose employees want to do their



work efficiently and well, and the customers who want to see their privacy protected, obviously require legal regulations in order to achieve a balance of interests. When working on the subproblems it should be experienced that there are very different ways to solve the problems. Of course, the various solutions also have different consequences - and vice versa: if certain consequences are undesirable, then one can always try to find other solutions that avoid these consequences. Technical decisions are almost never "without alternatives". Presenting them in this way shows quite clearly that a discussion of their effects should be avoided.

We imagine a supermarket with different departments:

- a scanner cash register (reads barcodes on the products, supplies article numbers and invoices)
- a warehouse management system with integrated database (receives article numbers, supplies prices and, if necessary, orders products from suppliers)
- an "intelligent" scale for fruits (recognizes a fruit with the help of a camera, generates barcodes)
- an advertising department (responsible for payback, advertising, special offers, ...)
- a security department (responsible for the payment of parking fees, customers with house ban, ...)

The implementations of the individual departments run on different computers and are processed by different groups. They communicate via a database on a server. And we do not use professional procedures, but only "naive" solutions that challenge improvements.

⁵⁰ from E. Modrow, The SQLsnap supermarket, Scratch2015 Amsterdam

17.1 Warehouse Management with SQLite

The warehouse management must be accessible. In this case we use a small *http server* with "built-in" *SQLite* database by Andreas Flemming⁵¹, which we can start with one mouse click. Then a menu window opens in which we select the desired database - here the database *supermarket*.

There we find five tables:

- products(pnr,identifier,maxstock,minstock,stock)
- suppliers(snr,supplier,zipcode,city,streetno)
- prices(pnr,snr,price)
- fruits(fnr,fruit,shape,size,colorcode)
- facerecognition(name,noseToEyes,mouthToEyes, mouseToNose)

We created this database e.g. with *SQLiteAdmin*⁵² and filled it with data.

For the SQL server, we first import the *SQLite blocks library* and the *Sprite SQLite server* (and thus also the required variables and access methods) in this order into an empty project. (We may also need the library "*Web services access (https)*" from the file menu, depending on the configuration of the server. For the sake of beauty, we take a picture of a warehouse as a costume of a *sprite warehouse*, send it to the correct position and make an *stamp*. Of course, we let the server establish the connection. We summarize the corresponding instructions in the block *Init* as a local method of the warehouse.



Our warehouse is waiting for the requests of the other departments of the supermarket. We leave the implementation of our own functionalities such as the automatic replenishment of stocks or the adjustment of prices to the tasks. However, in order to be able to answer inquiries, the warehouse establishes the connection to the database when the green flag is clicked.

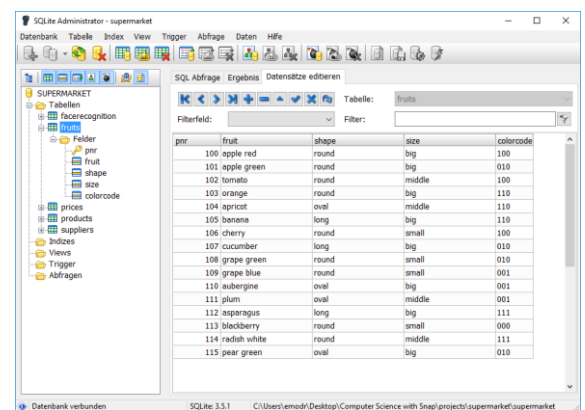

⁵¹ <http://www.uni-goettingen.de/de/http-server+mit+sqlite+fbcr+snap%21+%28download%29+andreas+flemming/582081.html>

⁵² Using a free tool, such as *SQLiteAdmin*, you can easily create databases and tables and enter data.

Our SQLite server can only do a few things: connect and compile the results of SQL queries.

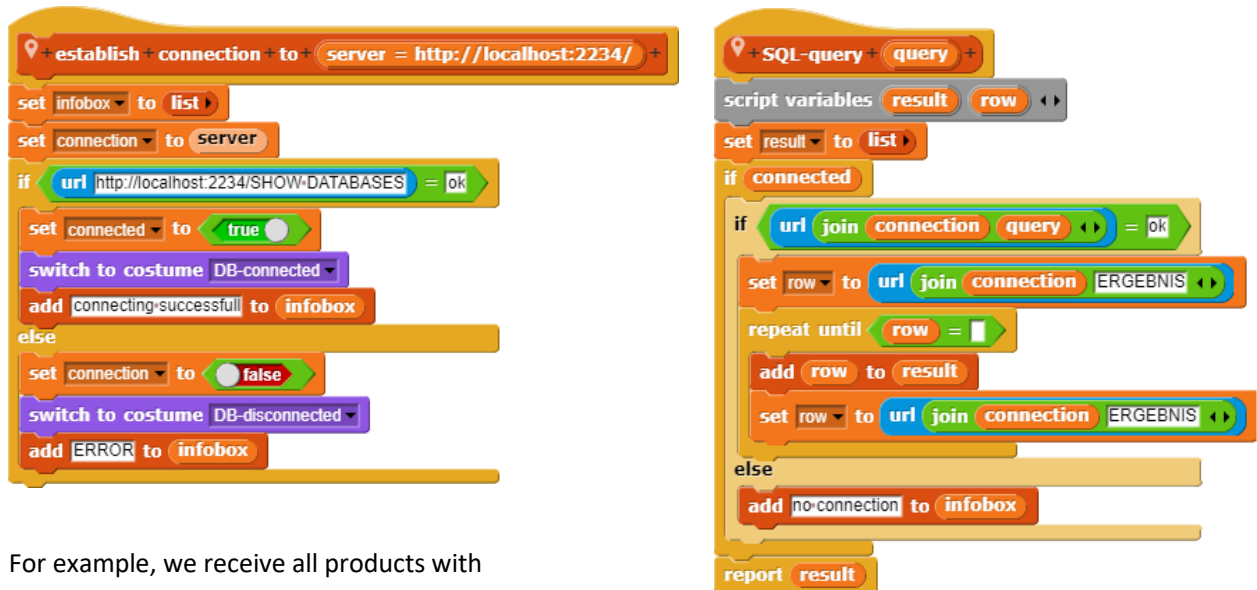

For example, we receive all products with



In addition, we give them the option of listing the tables available in the database and displaying the attributes of a table.



For example, to display all products, we compile a corresponding SQL query:

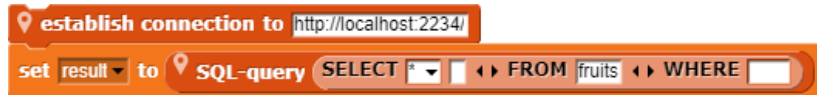

If you want to change data in the database, use *INSERT..INTO..* or *UPDATE...SET...-* statements..

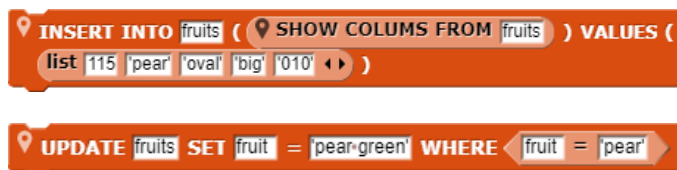

Attention: Character strings must be enclosed with apostrophes!

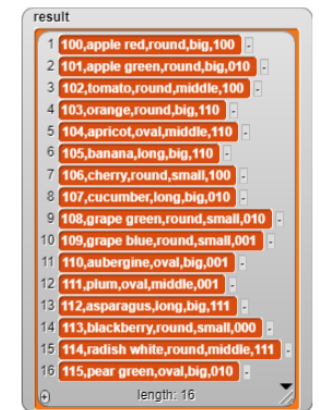
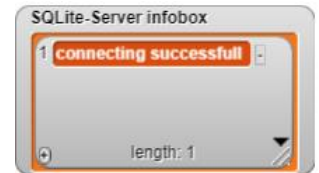

Tasks:

1. If some products have been sold, the inventory has fallen below the minimum value *minstock*. Order new products so that the *maxstock* level is reached again. Find the supplier with the lowest price for this product.
2. The supermarket wants to become an "organic supermarket". Change suppliers for all relevant products and adjust prices.
3. Add organic products and their prices to the product table in addition to the cheap products - if possible.
4. Every Saturday evening an update process is started in the warehouse because the prices of the suppliers may have changed. In this case the product prices have to be adjusted.
5. The supermarket works well but needs more money. Increase all prices by 10%.
6. The warehouse management needs statistics on sales per month and year. Collect the necessary data and display the sales in suitable diagrams.
7. Write a block for delete statements for SQLite.
Syntax: `DELETE FROM <tablename> WHERE <condition>;`
Example: `DELETE FROM suppliers WHERE supplier = 'Miller';`

17.2 The Scanning Cash Register

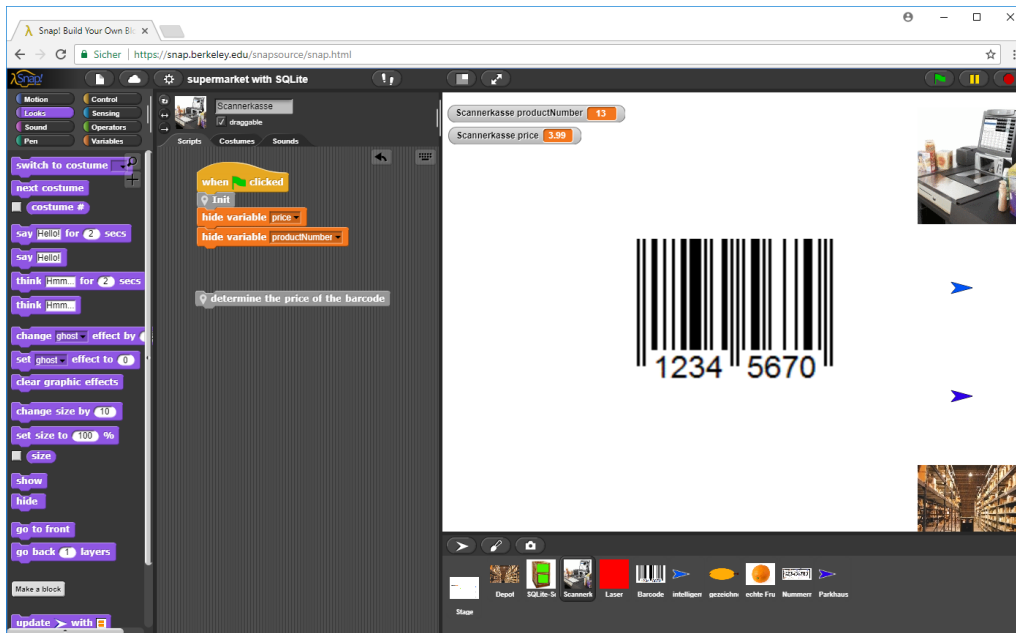

We have already dealt with a barcode reader before and therefore no longer have to deal with all the details here. For the sake of beauty, we take a picture from a scanner checkout as the costume of a sprite *ScanningCashRegister*, send it to the correct position and make a *stamp*. We summarize the corresponding instructions in the *Init* block as a local method of the cash register, which is called when the green flag is clicked. Additionally, we import the sprites *Barcode* and *Laser* from the old project *barcode scanner*.

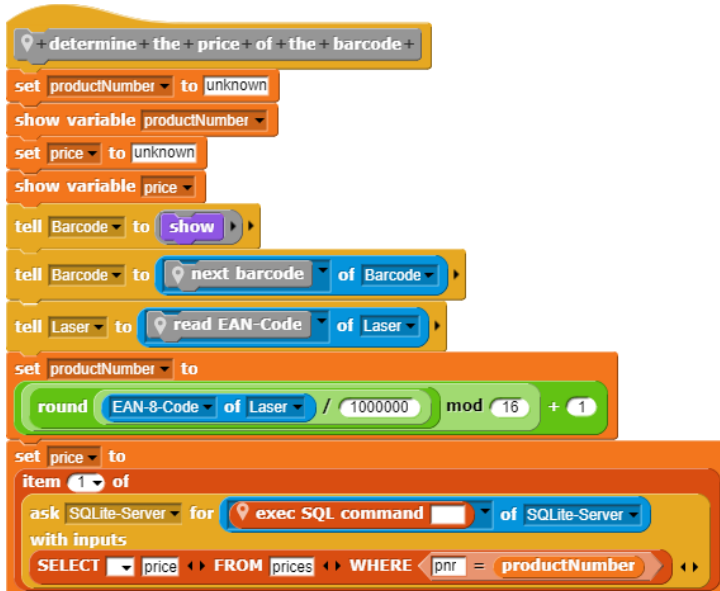
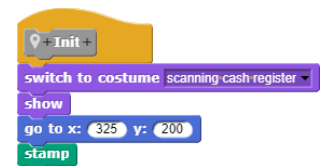

We receive barcodes from the sprite *Barcode*. If this is visible, the laser can determine the EAN code. The required variables and methods were imported as local variables. With their help the scanner determines the product code (which here must be smaller than 17) and asks the server for the price.

Tasks:

1. Draw some new costumes for a printer sprite that can print barcodes on the stage. First, the user should be asked for the number to be displayed.
2. Search for information about your national barcode system. In Europe you will find EAN codes. Change the printer sprite to a "national printer sprite" that prints these codes.
3. If the warehouse management does not know the price, an appropriate response should be made. Change the script to a usable version.
4. If the warehouse management works correctly, the cash register should provide answers in the form *<price>*,*<name>*. Make sure that.
5. Have the cash register produce invoices for the customers, including the date and time as well as all purchased products with prices and the total amount. Taxes should be declared as usual in your country.
6. The laser works quite slowly. Increase its speed.
7. Instead of always asking for individual data, the cash register can also get the current prices of the products in the morning and then work with this copied data. Change the system accordingly.
8. The warehouse can add new products to its database by reading the EAN codes at the checkout and entering the remaining data manually. Implement this option.

17.3 The Smart Scale

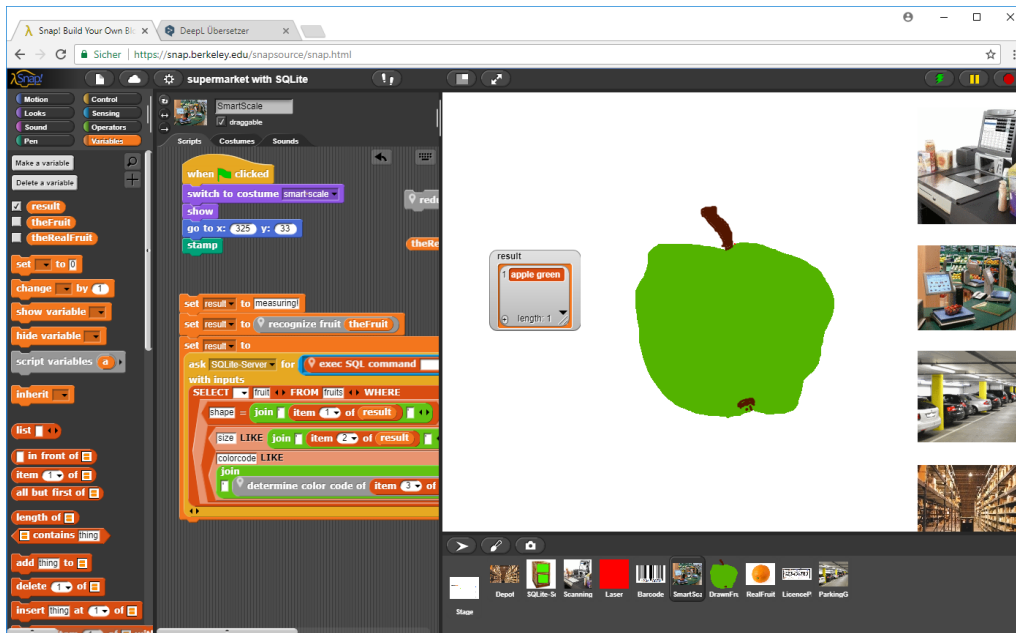

A sensation is looming in the supermarket: the fruit department has ordered an "intelligent" scale with a camera that is supposed to recognize and weigh fruit at the same time. Unfortunately, only the camera is included, the fruit recognition has to be implemented by yourself. The fruit department gets help from the staff of the scanner cash register, because they have already done similar things.

First, we try to find some criteria to distinguish fruits. We draw an apple, an orange, an apricot and a banana. The differences are obvious:

- apple and orange are round, the banana is long
- orange, apricot and banana are orange-yellow, the apple is (in this case) green
- the apricot is small, the others are bigger

But what do "round", "long", "yellow" and "green", "big" mean???

We know it, but the computer doesn't. We have to teach him.

We bring the object into the middle of the stage and send the laser from left to right and from bottom to top over the image. We measure the size of the object on these routes and calculate the ratio of the results. "Round" objects should have a ratio close to "1", "long" objects others. For "oval" objects we should actually use several measuring directions. But for us "oval" means "not round and not long".

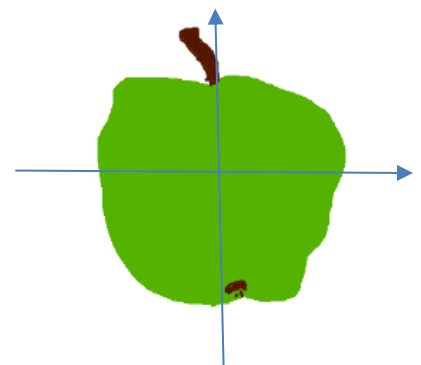

The *determine horizontal dimensions* - block of the laser provides a list with two values: left and right border. Correspondingly, the *determine vertical dimensions* - block lower and upper limit of the object. With these results we can decide whether an object is round, long or oval. And we know its size.

The color of the object is still missing. We import the already known library and use the blocks to determine the dimensions of a costume and to determine an RGB value.



```

+ determine the average color of fruit >> +
script variables
dx dy x y color costume width height R G B <<
set costume to ask fruit for copy of current costume
set height to get height of costume
set width to get width of costume
set dx to round width / 7
set dy to round height / 7
set R to 0
set G to 0
set B to 0
set x to dx
set y to height / 2
repeat 5
set color to getRGB from costume at x y
change R by item 1 of color
change G by item 2 of color
change B by item 3 of color
change x by dx
set x to width / 2
set y to dy
repeat 5
set color to getRGB from costume at x y
change R by item 1 of color
change G by item 2 of color
change B by item 3 of color
change y by dy
report
list round R / 10 round G / 10 round B / 10 <<
  
```

```

+ determine horizontal dimensions +
script variables distance result <<
set distance to 20
set result to list
go to x: -300 y: 0
point in direction 90
repeat until not color is touching ?
move distance steps
repeat until color is touching ?
move -1 steps
add x position to result
move 10 steps
repeat until color is touching ?
move distance steps
repeat until not color is touching ?
move -1 steps
add x position to result
report result
  
```

With their help we measure the color values at 5 points on the vertical and horizontal centerline respectively and determine the mean value from them.

Using these methods, the laser can determine the characteristic properties of a fruit.

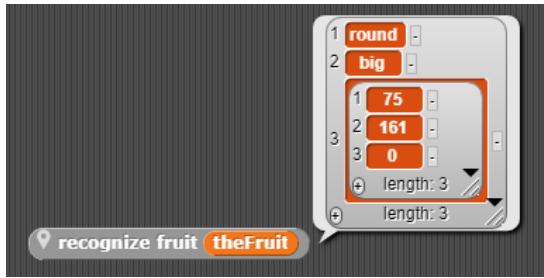

Normal fruits have different colors. But our RGB values can display $256 * 256 * 256$ colors, so 16,777,218. That's a little too many. We need a method to reduce the number of colors.

We try this: for each RGB channel we decide whether the color value is "high or "low". If it is high, we set it to 255, otherwise to 0, so we only get two possible values for each channel, so $2 * 2 * 2 = 8$ possible colors. With this procedure we try out whether we can see anything useful at all - or not.

```

+ determine + color + code + of + color + with + limit + limit # +
script variables result
if item 1 of color < limit
  set result to join 0
else
  set result to join 1
if item 2 of color < limit
  set result to join result 0
else
  set result to join result 1
if item 3 of color < limit
  set result to join result 0
else
  set result to join result 1
report result
  
```

```

+ measure + fruit +
script variables dx dy result left right up down h
go to front
set h to determine horizontal dimensions
set left to item 1 of h
set right to item 2 of h
set h to determine vertical dimensions
set down to item 1 of h
set up to item 2 of h
set dx to right - left
set dy to up - down
set result to list
if dy / dx < 0.4
  add long to result
else
  if dy / dx < 0.6
    add oval to result
  else
    add round to result
if max of dx and dy < 100
  add small to result
else
  if max of dx and dy < 200
    add middle to result
  else
    add big to result
add determine the average color of fruit to result
report result
  
```



It's looking good, isn't it?

So, we can equip the fruit scale with a method that asks the laser to determine the fruit data.

```

+ recognize + fruit + fruit >> +
script variables result
set result to
ask Laser for measure of Laser with inputs fruit
report result
  
```

And this result is used for a database query on the SQLite server. The color space is reduced as discussed and the quotation marks are placed around the data.

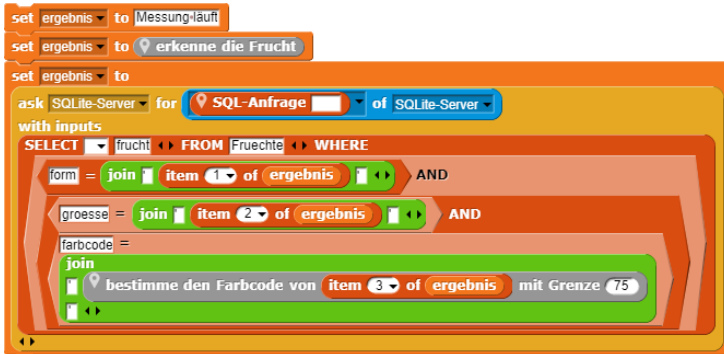

It's working!



After these successes the crew of the fruit scale becomes courageous and tries to analyze real fruit pictures.

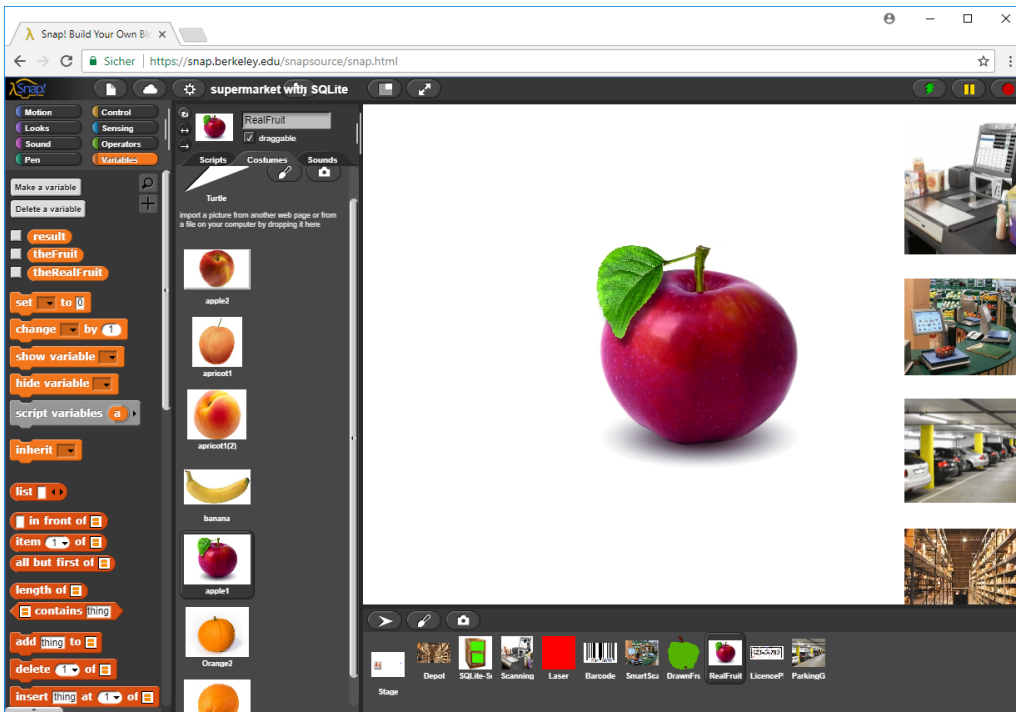

It reduces the number of colors as described...

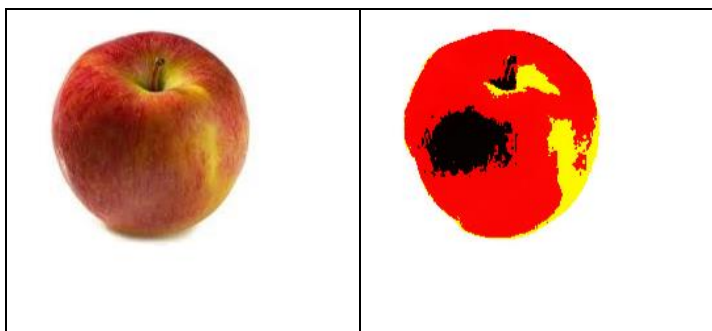

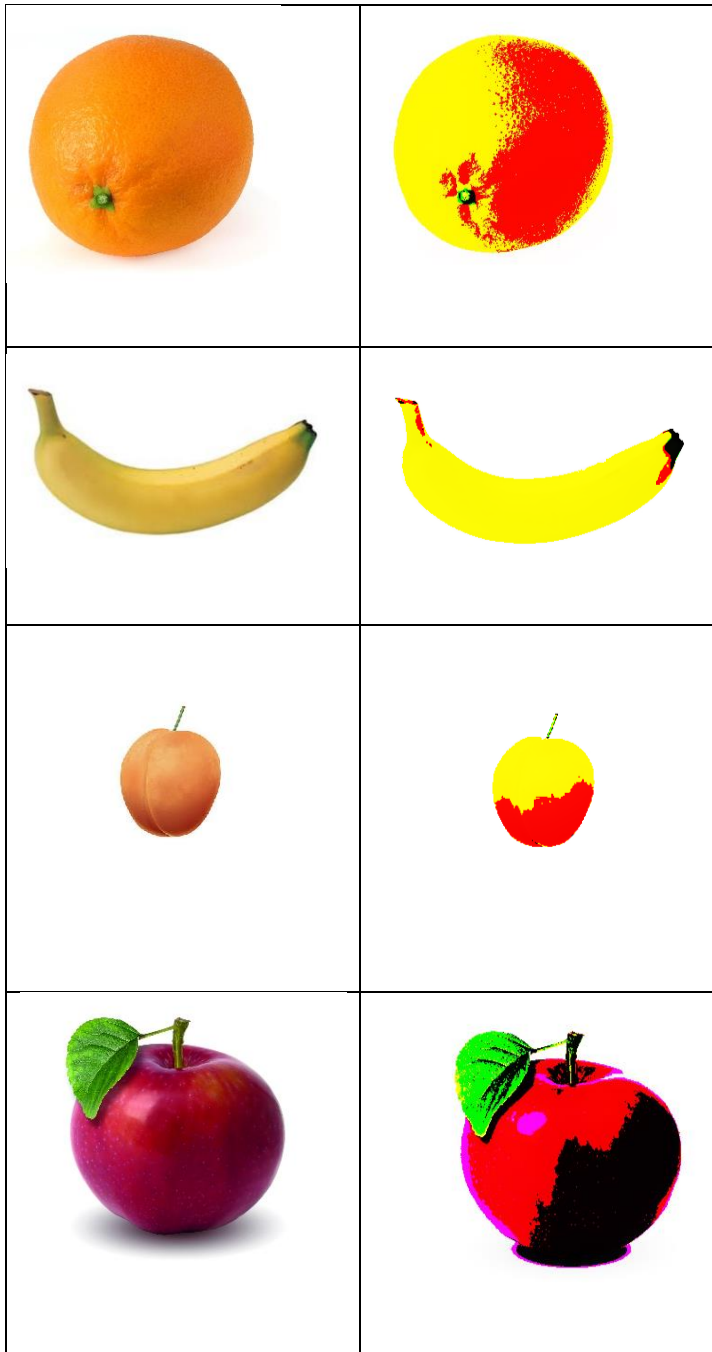

```

+reduce+ color+space+of+ fruit >> +
script variables
costume x y R G B width height color <<
warp
set costume to ask RealFruit for copy of current costume
set width to get width of costume
set height to get height of costume
set x to 0
repeat until x > width - 2
  set y to 0
  repeat until y > height - 2
    set color to getRGB from costume at x y
    set R to item 1 of color
    set G to item 2 of color
    set B to item 3 of color
    if R < 128
      set R to 0
    else
      set R to 255
    if G < 128
      set G to 0
    else
      set G to 255
    if B < 128
      set B to 0
    else
      set B to 255
    setRGB R G B at x y on costume
    change y by 1
  change x by 1
tell RealFruit to switch to costume costume
    
```

... and think that's enough. It'll take a while, but they've got time.



Finally, they calculate the average colour of the fruit as indicated and reduce the result again. If they do that with an orange, they get a pretty yellow.

```

determine color code of item 3 of result with limit 128
    
```

This means that the database can also be searched for "real" fruits - what more do we want?

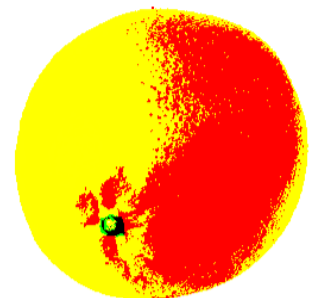

Now you have the full toolbox together for optical fruit determination:

1. Take a picture of a fruit and choose it as the costume of a sprite. You can take pictures with your smartphone or laptop camera. The background should be white.
2. Reduce the color space of the image.
3. Measure size and shape of the fruit.
4. Measure the mean color of the fruit and reduce it as well.
5. Calculate the color code of the fruit.

The obtained data *shape*, *size* and *color code* can be used as columns of a database table. We will have three different values each for size and shape as well as 8 possible color codes. This allows us to distinguish $3 * 3 * 8 = 72$ fruits. Try a "real" intelligent fruit scale in a department store - we're not that bad. 😊

Tasks:

1. a: Create a database table for fruits of the following type:

pnr	fruit	shape	size	color code
123	red apple	round	big	100
223	cherry	round	small	100
456	banana	long	big	110
...

- b: Add the table to your database.
- c: Write an evaluation method so that it provides the name and price of the fruit. To do this, use database commands.
2. The color reduction process is very coarse. Come up with a better way.
3. Our fruit recognition process only works well if the fruit is placed in the center of the stage and aligned horizontally. If we fit a sprite with a fruit picture as a costume, we can center and align the Sprite in the middle before we print the costume. Implement the procedure.
4. If we use a more detailed color code, we can distinguish more fruits. Would that be progress in any situation?
5. It could be that the background of the fruit is not white. Can you help?
6. You can drastically reduce the duration of color space reduction by using Jens Mönig's pixel library instead of *getRGB...* Do that. You can use the "light of old stars" as a template.

17.4 License Plate Recognition



The success with the smart scale goes through the department store like a wildfire. It also reaches the security department. Among other things, it is responsible for the parking garage. To simplify the payment of parking fees, the department installs automatic license plate recognition. Registered customers with a customer card and automatic billing no longer have to stop in front of the parking garage barrier - at least that's the hope.

Car license plates contain special character sets that facilitate character recognition by computers. In Europe they have a black border - and that is good for us. So, let's try to determine the numbers on the plate. (We leave the other signs to you.) Fortunately, we have already realized almost all tools for our project. All you have to do is ask the people at the smart fruit scale!

We are trying to develop an extremely simple method of license plate recognition. The result is very sensitive to changes in position and size of the license plates. But these disadvantages can be easily corrected by using a detailed measurement method. Take a look at the exercises!

A rectangular license plate with a black border. The text '123456780' is written in a bold, black, sans-serif font.

OCR (*Optical Character Recognition*) uses complex methods, often with neural networks, to recognize characters. Here we are inventing a simpler procedure that is similar to that of the smart scale. Because all our marks on the license plate are the same width, we can easily identify them once we have found the boundaries of the license plate. With the intelligent scale you can see how this happens. We continue to use their laser.

We can produce license plates quickly with the help of various generators on the Internet. We save them as costumes of a sprite *LicencePlate*.

We start by searching the top and bottom of the license plate for lines that do not contain black pixels. Their positions indicate the upper and lower edge of the relevant characters. Then we search from left to right for vertical lines with black pixels. When we find the first one, we also have the beginning of the first character. Then we search for the first vertical line without black pixels. Their x-position is the end of the first character. We have a "window" with the first sign in it. The next line with black pixels gives the width of the gap between the characters.

```

+ determine upper edge of plate from x0 # on costume >> +
script variables color x y blackPixelFound width height <<
warp
set width to get width of costume
set height to get height of costume
set blackPixelFound to false
set y to 10
repeat until blackPixelFound
set x to x0
repeat until blackPixelFound or x > width - 10
set color to getRGB from costume at x y
if item 1 of color < 50 and
item 2 of color < 50 and item 3 of color < 50
set blackPixelFound to true
change x by 5
change y by 1
report y - 1
    
```

```

+ determine lower edge of plate from x0 # on costume >> +
script variables color x y blackPixelFound width height <<
warp
set width to get width of costume
set height to get height of costume
set blackPixelFound to false
set y to height - 10
repeat until blackPixelFound
set x to x0
repeat until blackPixelFound or x > width - 10
set color to getRGB from costume at x y
if item 1 of color < 50 and
item 2 of color < 50 and item 3 of color < 50
set blackPixelFound to true
change x by 5
change y by -1
report y + 2
    
```

```

+ next vertical line from x0 # with black pixels between up #
and down # on costume >> +
script variables color x y blackPixelFound <<
warp
set x to x0
set blackPixelFound to false
repeat until blackPixelFound
set y to up
repeat until blackPixelFound or y > down
set color to getRGB from costume at x y
if item 1 of color < 50 and
item 2 of color < 50 and item 3 of color < 50
set blackPixelFound to true
change y by 1
change x by 1
report x - 1
    
```

```

+ next vertical line from x0 # without black pixels between
up # and down # auf costume >> +
script variables color x y blackPixelFound <<
warp
set x to x0
set blackPixelFound to true
repeat until not blackPixelFound
set blackPixelFound to false
set y to up
repeat until blackPixelFound or y > down
set color to getRGB from costume at x y
if item 1 of color < 50 and
item 2 of color < 50 and item 3 of color < 50
set blackPixelFound to true
change y by 1
change x by 1
report x - 1
    
```

Now we can move this window over all characters of the license plate and try to recognize the characters inside the field.

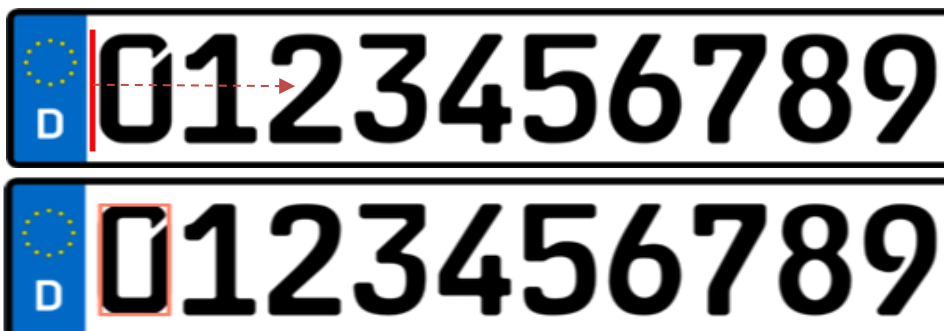

We can move a red rectangle across all characters by first determining the character width and the gap between the characters.

```

+recognize+ all+ letters+ on+ costume >> +
script variables xStart xEnd xPos number
set upperEdge to determine upper edge of plate from 45 on costume
set lowerEdge to determine lower edge of plate from 45 on costume
set xStart to next vertical line from 45 with black pixels between upperEdge and lowerEdge on costume
set xEnd to next vertical line from xStart + 2 without black pixels between upperEdge und lowerEdge auf costume
set charWidth to xEnd - xStart
set gapWidth to next vertical line from xEnd + 2 with black pixels between upperEdge and lowerEdge on costume
set xPos to xStart
set number to 0
repeat 10
  set number to join number look for the next sign from xPos on costume
  change xPos by charWidth + gapWidth
report number
    
```

```

+look+ for+ the+ next+ sign+ from+ x0 # + on+ costume >> +
script variables xStart xEnd code
set xStart to next vertical line from x0 - 2 with black pixels between upperEdge and lowerEdge on costume
set xEnd to next vertical line from xStart + 2 without black pixels between upperEdge und lowerEdge auf costume
draw rect between xStart upperEdge and xEnd lowerEdge color 255 128 100 on costume width 2
set code to recognize the sign from xStart on costume
tell LicensePlate to switch to costume with inputs costume
report code
    
```



The number recognition itself is still missing. As a starting point we take the characters with the rectangle around.

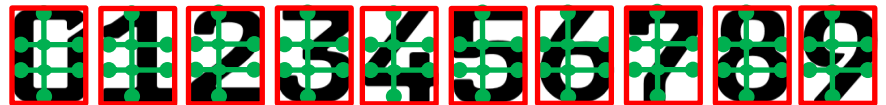

We imagine a "sensor field" consisting of three crossing lines. We measure the colors at the round points. We number the points as shown and look at the results in tabular form. (gray fields: result difficult to predict)

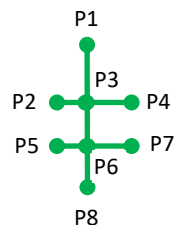

char	P1	P2	P3	P4	P5	P6	P7	P8	Code(s)
0	Black	Black	White	Black	White	White	Black	Black	00100100
1	Black	White	White	White	White	White	White	White	01111110
2	Black	White	White	Black	White	White	White	Black	01101010
3	Black	White	Gray	White	White	White	Black	Black	01011100 01111100
4	White	White	Black	Black	Black	Black	White	White	11010001
5	Black	Black	Black	Black	White	White	White	Black	00001100
6	Black	White	White	Black	Black	White	White	Black	0100100
7	Black	White	White	White	White	Black	White	Black	01111010
8	Black	Gray	Black	Black	White	White	Black	Black	00010100 01010100
9	Black	Black	White	Black	White	White	Gray	Black	00101100 00101110

Errors may occur with characters 3, 8 and 9 if the points are not very well adjusted. But that doesn't matter, because if we move the sensors P2, P3 and P7 a little bit so that they provide clear values, we can even do without the sensors P1, P2 and P8 (e.g.) and still have a usable code.

char	P1	P2	P3	P4	P5	P6	P7	P8	Code	Wert
0	Black	Black	White	Black	Black	White	Black	Black	10010	18
1	Black	White	White	White	White	White	White	White	11111	31
2	Black	White	Black	White	Black	White	Black	White	10101	21
3	Black	White	White	White	White	White	Black	Black	11110	30
4	White	White	Black	Black	Black	White	Black	White	01000	8
5	Black	White	Black	Black	White	Black	White	Black	00110	22
6	Black	White	White	White	White	White	White	White	00010	10
7	Black	White	White	White	White	White	Black	Black	11101	29
8	Black	White	Black	White	Black	White	Black	White	01010	10
9	Black	White	White	Black	White	White	White	Black	10111	23

A possible layout for the remaining sensors would be:



We choose a license plate with all ten characters. The sensors are placed in suitable places (here: (14|24), ...) and stored in a list to read the colors in the character window at the positions and to form a code number from the colors interpreted as a dual code. When we're done, we transform the code into the right character.

```

+recognize the sign from x0 # on + costume >> +
script variables x y color code points i dualcode <<
set points to
list
list 14 24 << list 35 28 << list 5 43 << list 13 45 << list 35 45 << <<
set code to 0
set dualcode to 16
set i to 1
repeat until i > length of points
  set x to x0 + item 1 of item i of points
  set y to upperEdge + item 2 of item i of points
  set color to getRGB from costume at x y
  fill circle x y radius 2 on costume color 0 255 0
  if item 1 of color > 100
    change code by dualcode
  set dualcode to dualcode / 2
  change i by 1
report code code -> cipher

+code + code # + --> + cipher +
if code = 18
  report 0
if code = 31
  report 1
if code = 21
  report 2
if code = 30
  report 3
if code = 8
  report 4
if code = 22
  report 5
if code = 10
  report 6
if code = 29
  report 7
if code = 26
  report 8
if code = 23
  report 9
    
```

Now the security department can ask the laser from their office in the car park which car has just arrived:

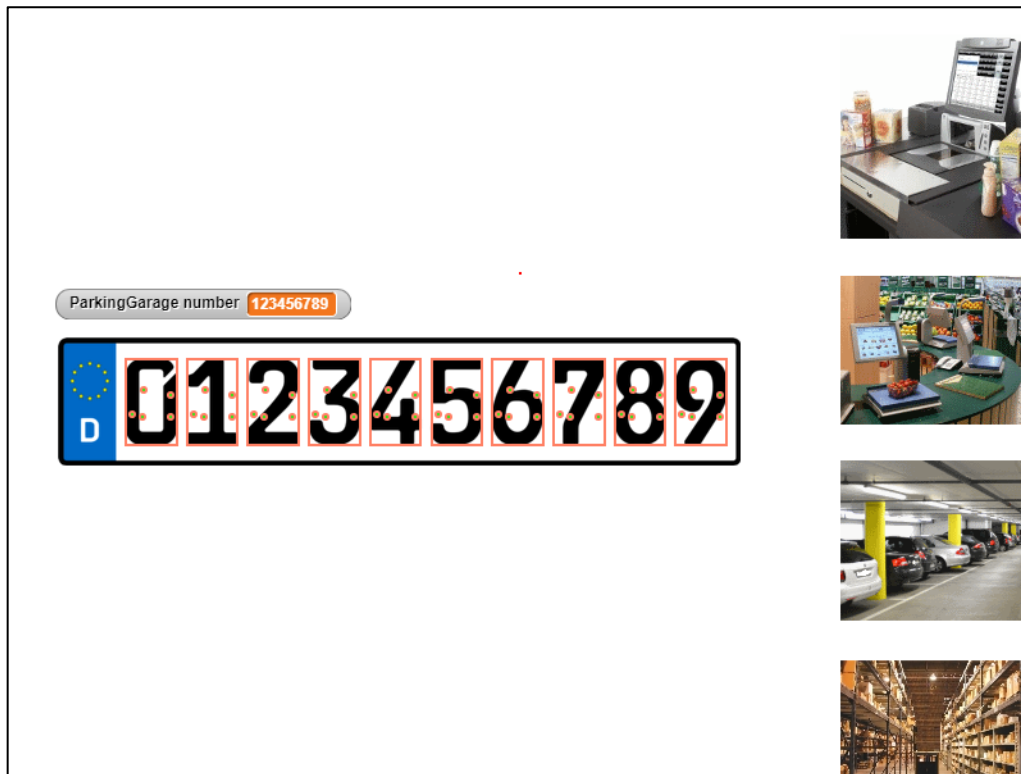

The result is particularly impressive for the advertising department, which immediately sees completely new applications for the process. Everyone's very proud of the security!

Tasks

1. In the examples, the sensor positions are given absolutely in pixels. Address the sensors relative to the size of the character rectangle.
2. Character recognition in the examples is very simple, but very sensitive to changes in the size and position of the license plate. Use more sensors to detect the characters more reliably.
3. Extend character recognition to the entire character set for vehicle license plates.
4. Character recognition programs can learn. If the script does not find any recognizable patterns, it should display its result and ask for the correct character. Save the patterns and the corresponding characters in a database table. Use queries to identify unknown patterns.
5. If you want to read dirty license plates, you won't find any sharp character boundaries. As a result, some sensors will produce errors. Improve the results in such cases by determining the "next correct code" of an incorrect code.

6. The recognition of dirty plates can be improved by converting the color image to a pure black-and-white image and closing the gaps caused by the dirt. Find out about suitable procedures for this purpose and implement one of them.
7. The security department needs a database of license plates and vehicle owners and their status (customer, company member, unwanted person, external parker, etc.). Can you help?
8. The license plate recognition turns out to be a great success for the security department. All its members are very proud of it and the other members of the company admire the "sheriffs". The advertising department now wants to use the data from the license plate table to honor customers as VIP customers who are frequently and for a long time present in the supermarket. These have special parking spaces near the elevator. Write a query to find VIP customers.
9. After some time, the VIP parking lots are occupied by pensioners and unemployed. Therefore, the advertising department extends the criteria for VIP customers by a minimum of turnover with their purchases. Because almost all customers use credit cards for payment, this is no problem. Improve VIP customer query accordingly.
10. The advertising department finds that it would be helpful to know not only a customer's turnover but also what they have bought. If it knows the interests of customers, it can provide them with special offers and special prices. Determine the additional tables required for this and their columns in the database. Write suitable queries.
11. The advertising department wants to know whether its advertising activities are successful. Do they reach customers? Try to answer these questions based on the stored data.
12. On German motorways, the truck tolls are determined using toll collect barkers that read the license plates of the passing vehicles. They read ALL plates and then delete those of the cars. Is this approach appropriate? Discuss the consequences if all vehicle numbers and their positions would be stored.



17.5 The Advertising Department

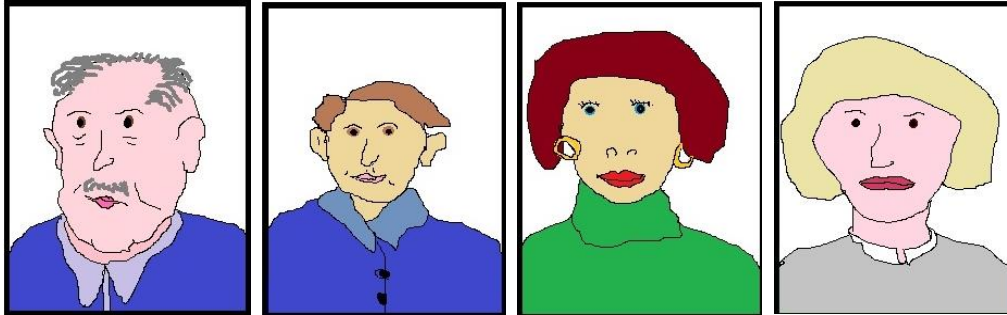

Paul

Peter

Mary

Hannah

The advertising department is excited about the possibilities of character recognition and wants to expand this area: they want to know who is in the supermarket. The aim is to identify customers with a face recognition program. We have already familiarized ourselves with the procedures for this, which is why we now only deal with possible consequences - in the form of tasks. These can be of more technical nature, but can also quickly lead into the field of computer science and society. The transition to this is a bit abrupt, of course, but in the media you can quickly find examples against which ours are still harmless.

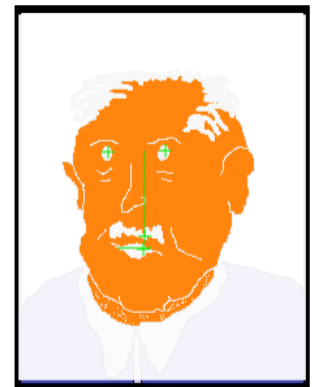

Tasks

"Technical" tasks can be derived quickly and with different demands from the previous project:

1. The four images used so far are very simple. Experiment with real images. Prepare them so that the scripts can be applied to them.
2. Look for additional parameters to distinguish faces.

But of course, we can also become "bitchy", and use the data obtained in a different way.

3. To identify the people on the pictures, a photo of the customers should be taken automatically every time they use their credit or customer card at the checkout. Discuss this idea.
4. The security department should keep "unwanted persons", i.e. shoplifters, tramps, ... away from the supermarket. If the facial recognition identifies persons whose data must of course be stored in a database, it triggers an alarm. Sometimes the process produces a lot of trouble, therefore the security department wants to keep the group of people a little more subtly away: the garage barrier does not open for them, the elevator is on strike, doors remain closed, ... Discuss this situation.

5. The advertising department has nice ideas too. There are many people in the supermarket who buy little or nothing. Others only buy special offers or cheap products. These are also declared "unwanted persons" because they take up space that should be better reserved for VIP customers. Discuss this situation.

And it can be really dangerous.







6. Unwanted people have to be noticed before they can be harassed. That's why the security and advertising departments put together profiles to identify them before they enter the supermarket for the first time. Develop such profiles and discuss the consequences.
7. The advertising department knows from the cash register what customers are buying. However, many customers are clearly interested in products without buying them. Therefore, the customers' path through the supermarket should be followed. This can be done with "number plates" on the shopping trolley, RFID chips on these, with the help of face recognition or their smartphone will be located. If they remain standing somewhere for a particularly long time, this can signal an unfulfilled desire to buy. Now the advertising department knows which products a customer is interested in. Personalized advertising for the corresponding products can be sent to customers on their smartphones, or the data of these customers can be sold to stores that specialize in these products. Discuss this situation.
8. The supermarket wants to focus on VIP customers. These in turn are identified via corresponding profiles (car brand, residential area, personal criteria derived from face recognition, shopping behavior, etc.). To avoid trouble, non-VIP customers should continue to be allowed into the supermarket, but they are subject to minor chicanes (see above). Discuss this situation.
9. Face recognition is always possible when a camera is available, i.e. in smartphones, "smart glasses", laptops, surveillance cameras, cars, ... Because the Internet is also available almost everywhere, the images can be compared with those in accessible social networks, databases, ...; accessible to the photographer or accessible to others who come to the images and are interested. Therefore, anyone who comes into the field of vision of a camera can be identified in the foreseeable future. Discuss this situation from different perspectives.

About the Notation of *Snap!*-Programs

There are repeated objections that *Snap!* programs on paper would be difficult to write down and exams would therefore be difficult to design, because it would probably not be possible to demand that the students work with crayons. Alternatively, sophisticated syntax suggestions in this area can be found on the Internet. Even if I don't see the sense of using syntax again for a largely syntax-free language in this way, and I think the algorithms should be written down in appropriate forms (*Nassi-Shneiderman-diagrams*, *UML*,...), here follows proposals on this subject.

It must therefore be shown that graphically formulated algorithms in *Snap!* can be recorded on paper. For this purpose, method heads and algorithmic basic structures must be representable. As with other systems, nesting also results from indentations and graphic aids.

Element	<i>Snap!</i> -block	handwritten	textual
method head			method name p1 p2
function head	 	 	function name p1: result
event handling (example)			when I receive: any message
FOR loop			repeat 10-times
head controlled loop			repeat until ...
variable declaration			variable a b c
one-way alternative			if ...

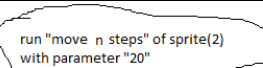
two-way alternative			if ... else ...
evaluation of a script			run ...
evaluation of a function			call ...
method call of another object			run „move n steps“ of sprite(2) with parameter “20”

Example: Sorting a list in *Snap!*, formally with indentations and "by hand".

```

+ sort theList : +
script variables i n h
set i to 1
repeat until i > length of theList - 1
  set n to i + 1
  repeat until n > length of theList
    if item n of theList > item i of theList
      set h to item n of theList
      replace item n of theList with item i of theList
      replace item i of theList with h
    change n by 1
  change i by 1
    
```

```

sort theList
variable i n h
set i to 1
repeat until i > length of theList - 1
  set n to i+1
  repeat until n > length of theList
    if nth element of theList > ith element of theList
      set h to nth element of theList
      replace nth elem. of theList with ith elem. of theList
      replace ith element of theList with h
    change n by 1
  change i by 1
    
```

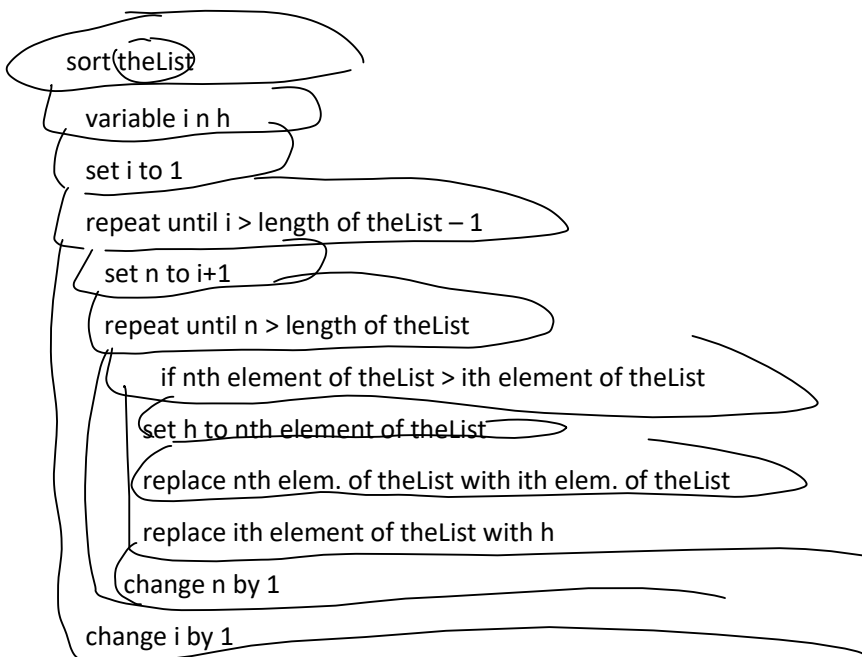

How To ...

Topic	Chapter
... change the size of the screen areas?	2.6
... resize the stage?	2.6, 8.2, 11.1, 14.4, 15.4
... change costumes?	2.7.4, 7.4.2, 9.3, 15.3, 16.3
... “nail” sprites on stage?	3.3, 16.3, 16.4
... use loops?	2.7.2, ...
... use alternatives?	2.7.4, ...
... start an animation?	2.7.4, 3.1, 3.2, 4., ...
... stop the execution of a script?	3.1
... use character codes?	3.3, 12.2, 15.2, 16.1
... display texts using sprites?	3.1, 5., 6.3
... convert characters to uppercase?	12.2, 15.2, 16.1
... use local variables?	2.7.2, 3.1, ..., 9.1, ...
... declare script variables?	2.7.1, 2.7.3, ...
... display a variable in a monitor?	3.1, 3.3, ...
... display script variables in a monitor?	5.
... change variable values with a slider?	11.
... use parallel processes?	3.2, 7.4
... use lists?	2.7.2, 2.7.4, 6., ...
... use higher list functions (MAP...OVER...)?	8.3, 8.6, 10.3, 11.2, 16.2
... plot a diagram?	2.7.5, 4.6, 13.4, 16.3
... output text on stage?	2.7.5, 3.3
... write your own methods?	2.7.1, ...
... differentiate between global and local methods?	2.7.1, ...
... assign a type to a parameter?	2.7.1, 3.2, ..., 12.1, ...
... create a drop-down list for a parameter?	12.5
... find just invisible blocks?	2.7.1
... send messages?	2.7.2, 3.1, ..., 16.3, ...
... access other sprites?	2.7.2, 7., 7.1, ...
... call methods of another object?	2.7.3, 2.7.4, 3.2, ..., 7., ...
... access attributes of other sprites?	4.2, 4.5, 4.6, 7., 7.1, ...
... send a message to specific objects?	3.1

... respond to messages?	3.1, ...
... clone objects?	2.7.3, 3.2, 7., 7.2, 7.3, 7.4, ...
... copy objects?	3.1, 7.1, ...
... find neighboring objects?	2.7.4
... request user input?	3.3, ...
... export a project?	4.1
... export global blocks?	4.1, 12.1
... export a sprite?	4.1
... create your own library?	8.2.2, 12.1
... copy a script to another sprite?	4.1
... measure time?	4.2
... respond to keystrokes?	4.3, 9.1
... run scripts step by step?	5.
... use recursions?	6.2, 8.1, 13.2
... display a table permanently?	6.2, 6.4, 12.4, 12.5, 15.4
... create new control structures?	6.4, 15.3, 16.3
... use code as data?	6.4, 7., 9.1, 12., 15.3, 16.3
... merge sprites into an aggregation?	7.4.2
... speed up the program flow?	8.1, 9.2, 9.3, 12.1, 14.2, 15.4
... access RGB values of pixels?	8.2, 8.3, 8.4, 8.6, 9.2, 9.3, 17.3
... use pentrails?	8.2, 8.4
... write JavaScript-functions?	8.2, 8.5, 9.3, 13.2
... react on colors?	9.1, 9.2
... produce sounds?	10.1, 15.2
... play sounds?	10.2, 15.2
... change sounds?	10.3, 10.4
... draw transparently?	8.5, 11.2, 11.3
... use an external server?	12.4, 12.5, 16.5, 17.1
... import a text file?	12.4, 16.2
... create and use predicates?	13.2, 15.1
... use a stack?	14.3
... hide blocks?	15.3
... draw the costume of a sprite in the program?	16.6

Index

- <attribute> of - block..... 17, 18, 32, 47, 48, 55
- Abelson, Harold..... 11
- acceleration sensor 180
- access control..... 51
- address23, 139, 182
- adjacency list..... 40
- adjacency matrix 44
- advertising department..... 6, 188, 204ff
- aggregation53, 57, 59, 211
- algorithm12, 208
- algorithm, genetic 123
- algorithmics.....4, 16, 117
- alternative162, 208, 209
- alternatives, nested.....140, 142, 158
- analysis of code 35
- anchor 59
- AND57, 60, 62
- animation34, 210
- approach, experimental 30
- ask 18, 47, 50, 125, 141
- attribute10, 11, 47, 50, 117ff, 190, 210
- Audio Comp..... 95
- automata theory 162
- automaton.....6, 139, 140ff, 149, 151, 155, 158
- automaton, cellular 149
- automaton, finite139, 140
- axiom.....135, 136

- Barabási, Albert-László 171
- barcode generator 94
- barcode scanner.....5, 77, 94, 192
- basic equation of mechanics31, 33
- basic structure, Algorithmic77, 82, 208
- beating 34
- Beauty and Joy of Computing..... 11
- behavior, social 150
- binary tree..... 46
- bioinformatics 111
- black and white image.....74, 75
- block cipher 123
- block... 9, 11ff, 63ff, 80ff, 108ff, 147ff, 210, 211
- block, empty..... 30
- block-editor15, 82
- bottom-up11, 30
- button ..15ff, 27, 78, 80, 85, 106, 172, 176, 184

- cable58, 180
- Caesar-encoding.....27, 109
- calculability..... 145
- calculator..... 134
- call 50
- Calliope.....6, 180
- camel problem 29
- capacitor.....5, 101, 102, 103
- C-curve 76
- chain rule..... 134
- change, temporal 34
- character code.....109, 210
- character recognition200, 204, 206
- character 9, 15, 25ff, 106ff, 135ff, 200ff
- checkbox 117

- children..... 10
- class9, 10, 12, 32, 48
- classroom project 14
- clock..... 62
- clone.....10, 15, 17, 26, 47ff, 58, 167, 172, 185
- clone, dynamically generated..... 52
- clone, statically generated..... 47
- cloning..... 9, 26, 36, 47ff, 52ff, 59, 60, 173, 211
- cloning, dynamic..... 47, 52, 57
- cloning, static..... 48, 57
- code.... 12, 25ff, 47ff, 77ff, 110, 145, 202ff, 211
- code, unevaluated 18
- color chanel..... 71
- color code..... 199
- color cube..... 68, 69, 76
- color mixer..... 5, 71
- color separation 76
- color space 197
- coloration 170, 171
- command block 15
- computer algebra 6, 124
- computer science ..1ff, 27, 117, 145ff, 182, 206
- computer voice..... 143
- concept, informatical..... 12
- conclusion, logical 34
- conflict of interests..... 188
- connectivity 6, 169
- consequence, political 187
- consequence, social..... 8, 88
- context menu15, 24ff, 78ff, 102, 113, 119ff
- control output 35
- control structure.. 12ff, 44, 109ff, 156, 172, 211
- control16, 18, 47, 78
- cooperation 4, 10, 30
- coordinate system21, 71, 163, 167
- copy machine 145
- copy 48
- costume. 18ff, 27, 59ff, 70, 74, 78, 82, 141, 211
- creativity..... 3, 7
- cryptanalysis..... 29
- c-shaped command 45, 147
- curve, recursive 63
- customer card..... 200, 206

- data source, external 117
- data store 48, 49
- data structure 11, 12, 176
- data structure, higher..... 44
- data type, atomic..... 37
- database 12, 117ff, 188ff, 198ff
- datenbase query..... 197
- decidability 145
- decoding 28, 80
- default position 145, 146
- delegation.....4, 10, 12, 48, 53, 57
- DELETE FROM 191
- derivative..... 129, 131, 134
- desert ant 29
- diagram 4, 21, 31, 76, 100, 150, 154, 210
- dialog 37, 119
- dictionary..... 46

- digital simulator5, 57
- digitization offensive 7
- Dijkstra method.....4, 40
- dimension..... 44
- DNA sequencing5, 111
- download directory 113
- draggable..... 27
- dragon curve 76
- draw statement.....6, 135, 136
- drip painting5, 72
- drop-down list118, 119, 210
- duplicate..... 24

- EAN-8-code77, 94, 192
- echo chamber..... 187
- edge detection5, 74, 76
- electron source5, 101, 102
- elementary magnet..... 52
- Eliza 123
- encryption5, 29, 51, 109
- ENT clinic 100
- entry58, 61, 62
- ER diagram 117
- error message156, 158, 161
- error 9, 11, 35, 36, 84, 126, 158, 202, 204
- event control 176
- event handling..... 27
- evolution6, 176, 179
- exit.....58, 60, 61, 62
- export blocks30, 69, 108
- export 27, 32, 33, 34, 82, 108, 114, 211
- export31, 82, 113
- expression, logical 125

- face recognition 5, 88, 94, 189, 206, 207
- feed-forward-method 61
- field, electric..... 5, 102, 103, 104
- field, magnetic..... 101
- final state.....140, 145
- first-class 12
- fitness function..... 123
- flag, green 13, 23, 32, 85, 102, 113, 189, 192
- flu.4, 14, 18
- for all sprites..... 15, 16, 25, 30, 106, 125
- FOR loop..... 4, 44
- for this sprite only15, 16, 78, 125
- forgetting56, 126
- freezing..... 35
- frequency analysis.....5, 29, 113, 115
- function term 6, 124, 125, 129, 134
- function 34, 38, 50, 60, 70ff, 91, 106ff, 131ff
- function, trigonometric 134

- galaxy 70
- GapMinder 163
- gate 5, 57, 60, 61, 62
- ghost-effect 102
- gnomsort 46
- goat problem..... 29
- grammar..... 138
- graph 6, 14, 18, 21, 40, 131, 134, 145
- gravitational force 26
- grayscale image 74
- grid automaton 152
- gross national product 150

- hardware 12, 180
- Harvey, Brian 11
- hat block 18, 38
- hearing test 5, 99
- Helmholtz coil..... 101
- help page 36
- Herget, Wilfrid 141
- Hertz, Heinrich..... 34
- hide primitives 146
- hide variable 35
- higher order list operation 165
- Hilbert curve 64, 65
- house ban 188
- http block 12
- hub 171
- hydrogen bond 169
- hyphenation6, 139, 141, 155

- IBAN number 155
- idea, own 7, 30
- image recognition..... 5, 77, 94
- immunisation..... 14
- impact, social..... 188
- import of table data 6, 164
- import..... 113, 164
- infection chain 169
- infection 14, 18
- infinite loop 11, 25
- informatics and society 77
- informatics system8, 117, 162, 169
- inheritance4, 10, 48, 53, 57
- initial state 140, 145
- initial value 16, 17, 37
- input slot options 119
- INSERT..INTO 190
- insertionsort 46
- instance variable..... 31, 60
- instance 9
- internet..11ff, 39, 76, 80, 117, 149, 170ff, 200ff
- introduction example 37

- JavaScript3, 63, 66, 68, 71ff, 88ff, 124, 126, 211
- JK-Master-Slave-FlipFlop 62
- join..... 80, 106, 165

- key27, 109, 110, 123
- keyboard..... 97

- label 21, 27
- labyrinth 56
- lambda calculus 12
- language, block-oriented 4, 9
- language, context-free 135
- language, object-oriented 4, 9
- launch 25, 49, 57, 59, 60, 97, 98
- lazy evaluation..... 125
- learning process 10
- learning Step..... 54
- LED..... 5, 57, 61
- length of 28, 106, 110
- letter..... 106, 109
- Levenshtein distance 123
- library 5, 21, 27, 44, 66ff, 82ff, 106ff, 189ff
- license plate.....6, 74, 94, 155, 200, 201, 204
- Lieberman, Henry 10, 48

- life expectancy163, 166, 167
 Lindenmayer, Aristid 135
 line graphics5, 63
 link.. 77, 169, 170, 171, 172, 173, 182, 183, 187
 LISP11, 12
 list..... 15ff, 37ff, 66ff, 75ff, 135ff, 165ff, 175ff
 logical value..... 37
 login script..... 113
 LOGO for the poor6, 156, 162
 looks13, 35
 loop 18, 25, 37, 78, 110, 116, 123, 156, 208
 L-system6, 135, 138

 magnet4, 52
 mail address6, 139, 140
 make a block15, 25, 85, 106
 make a variable16, 78
 makro27, 37, 145
 map-function.....74, 76, 109
 matrix4, 44, 45, 46
 Mealy-machine..... 141
 media education4, 7
 menu bar 13
 message.. 16ff, 23, 24, 32, 52, 81, 166, 208, 210
 meta tag182, 183
 methode..... 3ff, 46ff, 106, 125ff, 172ff, 210
 methode, global25, 30, 44, 87
 methode, locale .17, 25, 49ff, 85, 177, 189, 192
 methode, parallel 25
 methoden call18, 52
 mini language..... 162
 Mönig, Jens 3, 6, 11, 95, 163, 165, 199
 monitor27, 35, 210
 Moore neighborhood 155
 motion13, 63
 motivation 30
 mouseclick..... 11, 15, 23, 59, 170, 172, 189
 multiplier14, 18, 22
 music5, 7, 8, 95, 97
 mutation.....123, 176
 my block 16, 18, 47, 59, 60

 NAND gate.....57, 60, 61, 62
 Nassi-Shneiderman diagram 208
 navigation system 143
 neighbors 18, 41, 150, 151, 153, 155
 network94, 169, 207
 network, neural.....169, 200
 network, social 8
 neuron54, 55
 node40ff, 169, 170ff
 NOT gate 62
 number 25, 37ff, 77ff, 126ff, 155, 156, 165, 200
 number, smallest..... 38

 object recognition 74
 object10, 15, 48
 OCR..... 200
 OOP 3, 10, 17, 47, 48, 182
 operation, recursive 125
 operator28, 80, 106, 109
 opinion-forming, political..... 172
 OR gate.....60, 62
 output window 13, 35, 37, 47, 59, 78, 113
 overwriting methods..... 53

 PageRank6, 182, 183, 184, 186, 187
 palindrome 123
 parameter..... 9, 12ff, 37ff, 70ff, 106, 114ff
 parent 10
 Pareto distribution 171
 parking fee..... 188, 200
 parking garage 200, 204
 parser 125, 128, 129, 138, 158
 parsing..... 6, 125, 128, 131, 134, 156
 partial problem..... 9, 10, 93
 parts 59, 60
 passport photo 88
 password request 51
 password, complex..... 155
 path search 41
 Pavlovian learning 55
 payback 188
 Peano curve.....76
 pen.....21, 27, 63, 94, 95
 pentrails.....63, 66, 71, 211
 phase transition 170
 pheromone trail 29
 PHP 113, 117
 physical computing..... 180
 physics30, 31, 101, 104
 pivot element 39
 pixel graphics..... 5, 66, 68
 pixel 66ff, 85ff, 90, 91, 102, 152, 200, 211
 pixels.....66, 67, 70, 74, 75, 85
 planet image 25
 planet transit 76
 plants, artificial 6, 135
 plausibility check 51
 play sound until done 143
 plot 96
 Poisson distribution 170
 population data 165, 166
 predicate .53ff, 124ff, 134, 139ff, 155, 162, 211
 prisoner's dilemma 6, 149
 probability of infection 14
 product code 192
 product rule..... 130
 program functionally 6, 124, 125
 programming language9, 11, 156, 161, 162
 programming, object-oriented3, 4, 10, 47
 programming, text-based 156
 project, work sharing..... 188
 protocol 169
 prototype.....9ff, 25, 47ff, 167, 173, 184

 question, ethical 150
 question, social..... 163, 169
 queue44, 46, 48, 51
 quicksort..... 4, 39

 random network..... 6, 170, 171
 random number 37, 45, 177
 random value 24
 rank of a web page 183, 184
 reference 15, 17, 48
 reference manual 15, 47
 report 107
 reporter 15, 49, 50, 84, 106, 118, 120
 resonance 34
 RGB model..... 5, 66

- RGB..... 5, 66ff, 74, 76, 85, 86, 91, 195, 196, 211
 road sign..... 82
 robot4, 53, 54
 RS-FlipFlop..... 62
 rule system.....135, 136
 run.....49, 50, 60, 163

 sample rate 96
 samples96, 97, 100
 say 35
 scale, smart188, 194
 scalefree network.....6, 171, 174
 scanner checkout 6, 188, 192, 194
 scanner..... 162
 SCHEME..... 11
 SCRATCH.....3, 11, 13, 143
 script level 15, 31, 80, 82
 script variable... 17, 24, 35, 39, 80, 86, 129, 210
 search engine 182
 security department.... 188, 200, 204, 205, 206
 SELECT120, 121
 sensing 16, 17, 18, 32, 47, 78, 95, 125, 141
 sensor field..... 202
 sensor.....53, 202, 203, 204
 sensorboard6, 180
 seroconversion time.....14, 18
 server 12, 113ff, 180, 188ff, 192, 197, 211
 set..... 16, 44, 48, 50, 78, 79
 shakersort 46
 show variable 35
 side effect..... 125
 Sierpinski curve 76
 simulation..... 4, 14, 30, 34, 146, 151
 script 9ff, 31ff, 52, 78ff, 131, 147, 152, 206, 211
 slider..... 71, 102, 103
 small world phenomenon 170
 smartwatch 180
 SnapMinder..... 6, 163, 165, 167, 168
 snowflake 63
 social credits..... 94
 socket..... 5, 57, 58, 59, 60
 solar system4, 25, 26
 sorting by selection 37
 sorting method..... 46
 sorting 4, 37, 38, 39, 209
 sound named..... 96
 sound recorder..... 95
 sound.... 5, 8, 13, 95, 96, 97, 100, 141, 143, 211
 special offer.....188, 207
 spin grid..... 155
 split.....106, 143
 spread of diseases 172
 spreadsheet..... 164
 spring pendulum4, 30
 sprite 10ff, 47ff, 78, 80ff, 103, 113ff, 141ff
 SQL database.....5, 117
 SQL 5, 117, 118, 120, 122, 189, 190
 SQLite 6, 117, 189, 190, 191, 197
 SQLiteAdmin..... 189
 stack operation.....6, 136, 138
 stack 44, 46, 135, 136, 137, 211
 stage size 137
 stage... 13, 14, 15, 16, 66, 71, 81, 102, 103, 104
 stamp 94
 start time..... 24

 state change 142
 state diagram..... 140
 state graph 145, 158
 stop button, red 35, 52
 stop..... 24
 string function 106
 string operator 106
 string processing..... 124
 string... 5, 27ff, 37, 77, 106ff, 126ff, 164ff, 180ff
 substitution 116, 135, 136
 sum rule..... 129
 supermarket6, 77, 117, 188ff, 205, 206, 207
 Sussman, Gerald und Julie 11
 swimming 4, 23
 switch5, 59, 60, 61
 switching time 61, 62
 syntax diagram125, 127, 134, 139
 syntax 11, 128, 134, 162, 191, 208
 system time 32, 34

 tab 164
 table view 45
 teaching, creative 7, 8
 team work 9
 tell.....15, 18, 49, 81
 testing machine 145, 147
 text file 5, , 51, 113, 164, 211
 text input 27, 28
 text output 27
 text106, 120, 162, 210
 theatre bistro..... 29
 thread 25
 threshold value..... 54, 74, 76
 time announcement, automatic..... 143
 timer 32
 tools.... 7, 21, 27, 44, 95, 106, 109ff, 163ff, 189
 top-down approach.....11, 30, 111, 124, 125
 topic, political 182
 topology 169
 torus world 153
 touch sensor 53, 55
 touching..... 78
 towers of Hanoi 36
 transfer procedure 29
 transparency.....66, 72, 85, 86, 102, 103
 tree structure 186
 troubleshooting..... 4, 35, 36
 truck toll 205
 turbo mode..... 63, 74
 Turing machine.....6, 139, 145, 146
 turtle graphics 63, 135
 turtle.....135, 137, 156, 162
 type cast 27
 typing.....15, 25, 106, 147, 210
 ultrasonic sensor 54, 55
 UML diagram 57, 208
 unicode.....28, 106, 109, 110
 UPDATE...SET 190
 upvar 45
 url block..... 114

 vaccination protection..... 172
 variable. 4, 15ff, 32ff, 70ff, 102ff, 164, 209, 210
 variable, global24, 27, 35, 37
 variable, local.....25, 32, 35, 102, 210

variables 15, 16, 24, 28, 37, 38, 78, 80, 82
vector26, 104
verification code.....77, 94
Vigenère encryption109, 141
VIP-customer205, 207
visual stepping.....35, 36
visualization..... 8, 23, 30, 37, 95, 96, 163
Von-Neumann neighborhood149, 150

wait until 35
wait35, 125, 141
warehouse management .6, 188, 189, 191, 193
warp63, 65, 66, 85, 107
WAV file.....95, 143
way, shortest.....4, 40
web services access (https) 189
webcrawler..... 182
website 6, 169, 182, 183, 184, 186
weight54, 183, 187
with inputs17, 49
Wolfram, Stephen 155
working copy 89

XML file82, 114
XOR encryption 29
XOR gate.....29, 60, 62

